



Parts List & Instructions

815 Rice Lake Street, Owatonna, MN 55060

Phone: 800-443-2476 / 507-451-5430

www.gandy.net / Email: sales@gandy.net

28368584

Calibration Pan for 36" Drop Spreader

Carton Contains the Following Parts:

- 1..... 28368584-1 Calibration Pan Only (For 36" Spreader)
- 1..... 28248584-H Hardware Bag Cal. Pan (For 24" & 36")

Contents of hardware Bag 28248584-H

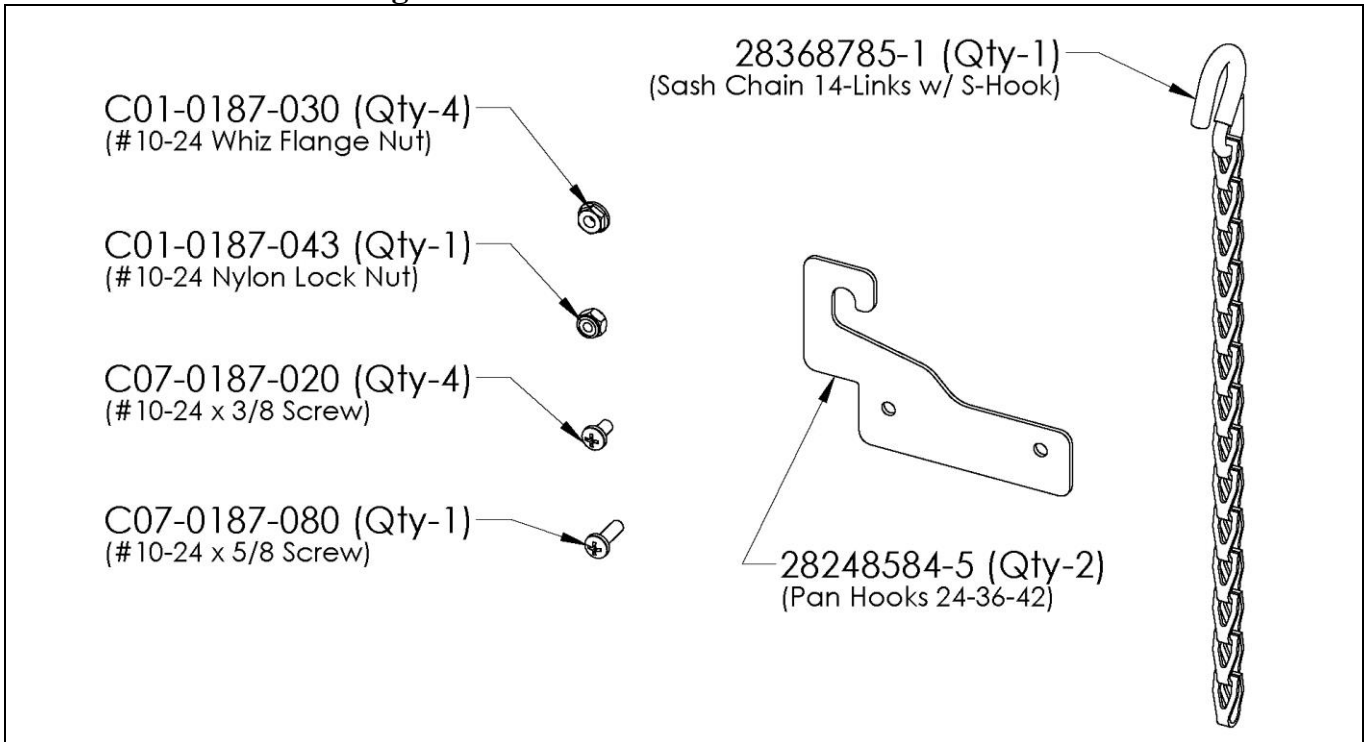

Assembling Calibration Pan:

Fasten both Pan Hooks (part #28248584-5) one to each to the outside ends of the calibration pan using the #10-24 x 3/8 screws & whiz flange nuts as shown. Tighten securely.

Next fasten the Sash Chain (Part 328368785-1) to the center hole using the #10-24 x 5/8 screw & nylon lock nut. Do not over tighten as the chain needs to pivot freely on the screw.

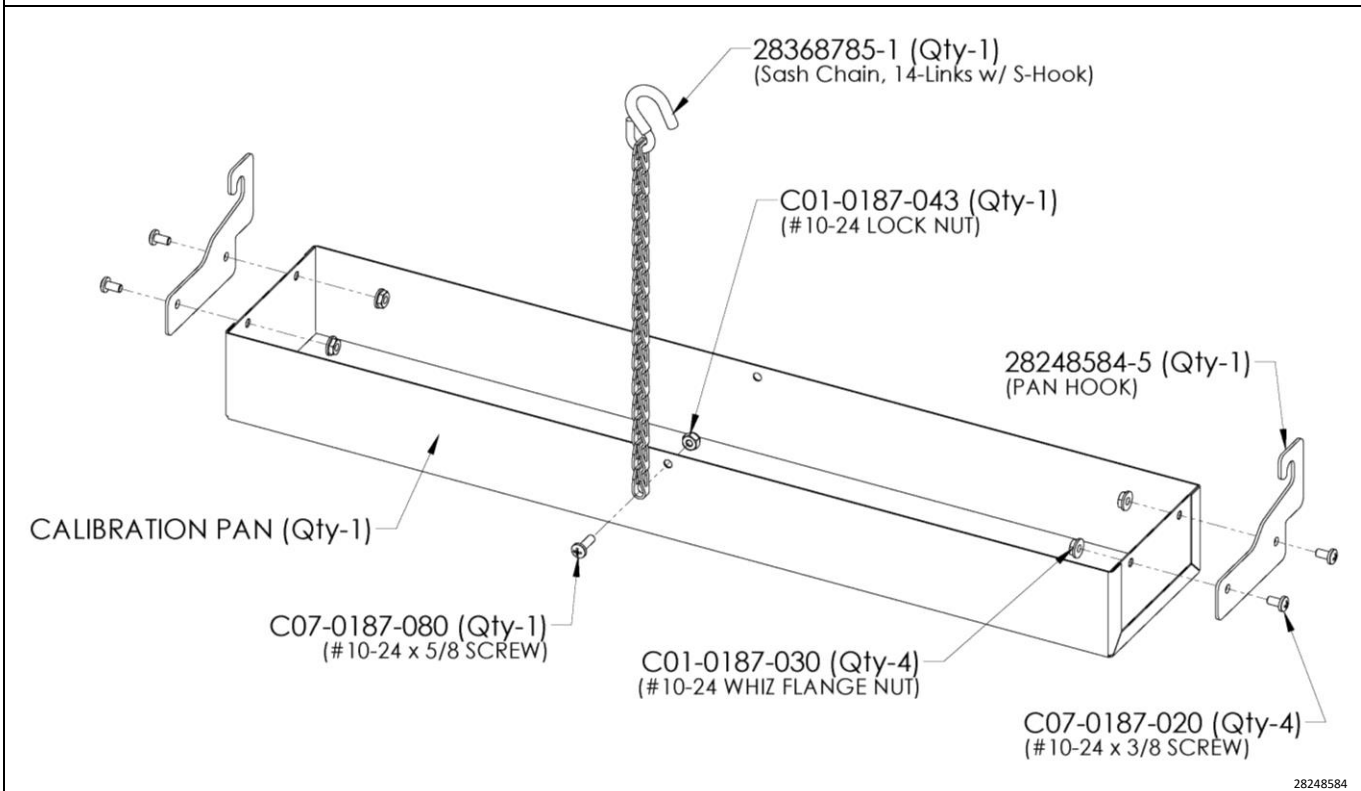

Spread-Plate:

Lift end of spreader and pivot spread-plate to the handle side and connect spread-plate hanger chain to hopper in between hopper lifting handle as shown in pictures below.



Cal Pan 24-36 Pic-1 & Cal Pan 24-36 Pic-2

Install Calibration Pan:

Connect the Pan Hooks (part #28248584-5) that were assembled to the calibration to the rods holding the spread-plate in place.

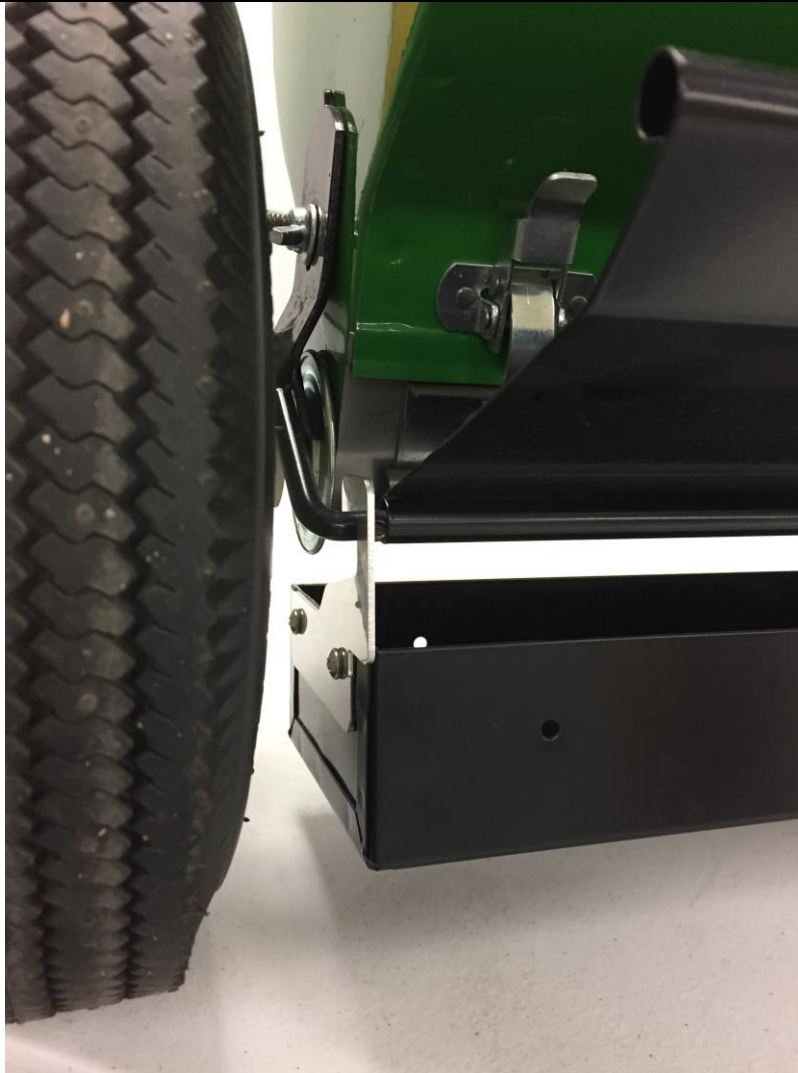

Cal Pan 24-36 Pic-3

Calibration Pan Chain Connection: (Push-Type Spreader)

With Calibration Pan in place connect the chain that was assembled to the Calibration Pan to the same bracket at the spread plate chain was connected to. Pictures shown below are for a push-type spreader.



Cal Pan 24-36 Pic-4 & Cal Pan 24-36 Pic-6

Calibration Pan Chain Connection: (Pull-Type Spreader)

With Calibration Pan in place connect the chain that was assembled to the Calibration Pan to the same bracket at the spread plate chain was connected to. Pictures shown below are for a pull-type spreader. For a pull-type with a tractor hitch the chain assembled to the calibration pan will need to be shortened to get the pan to hang level.



Cal Pan 24-36 Pic-8 & Cal Pan 24-36 Pic-7

28248584
May 17, 2021
Printed in the USA