



Parts & Assembly Manual

815 Rice Lake Street, Owatonna, MN 55060
Phone: 800-443-2476 / 507-451 5430
www.gandy.net / Email: sales@gandy.net

Turf Tender®

36H13 (Beginning w/ Serial #153973)

36-inch Variable Rate Spreader

Push Model w/13-inch Pneumatic Tires and Spread Plate

(All Hardware in Hardware Bag Unless Otherwise Specified)

Carton Containing the Following Parts:

Diagram #1

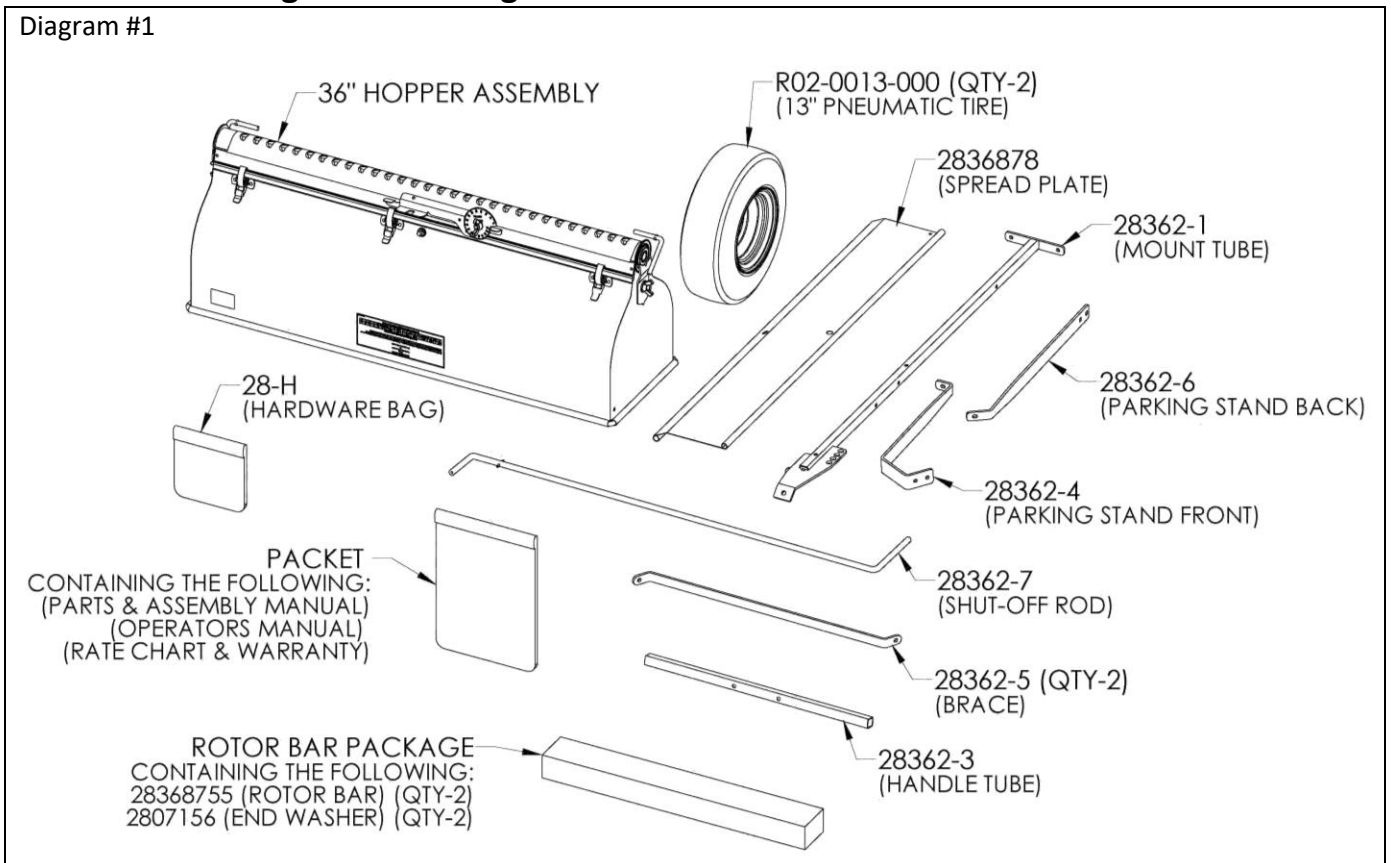

Rotor Bar Package (for 36" Spreader) Contents:

Diagram #2

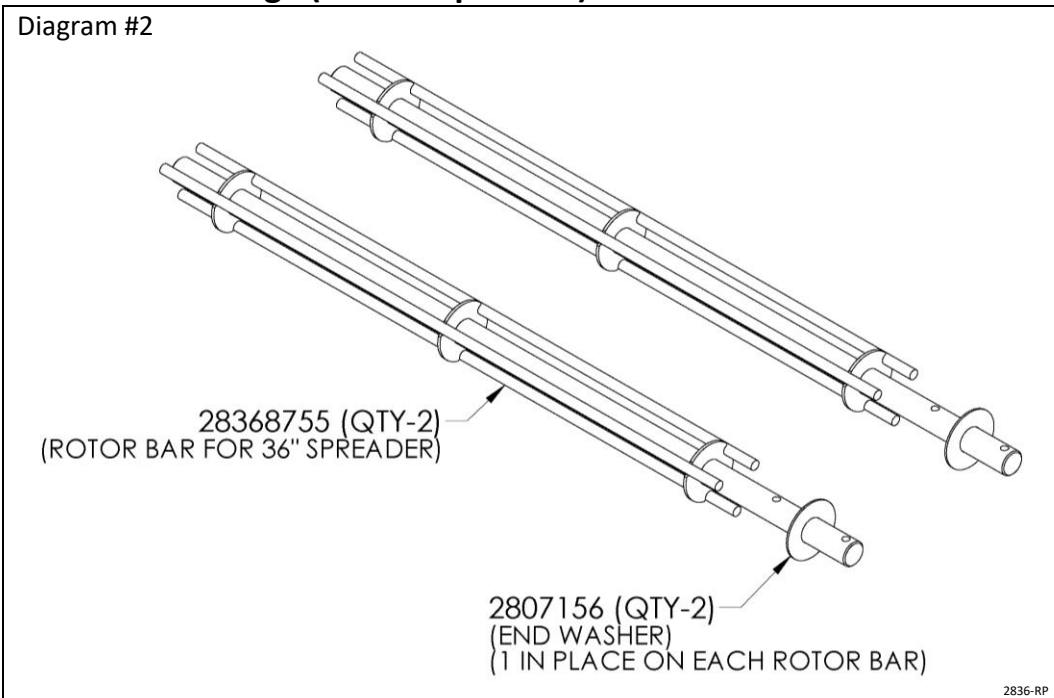

Hardware Bag 28-H Contents:

Diagram #3

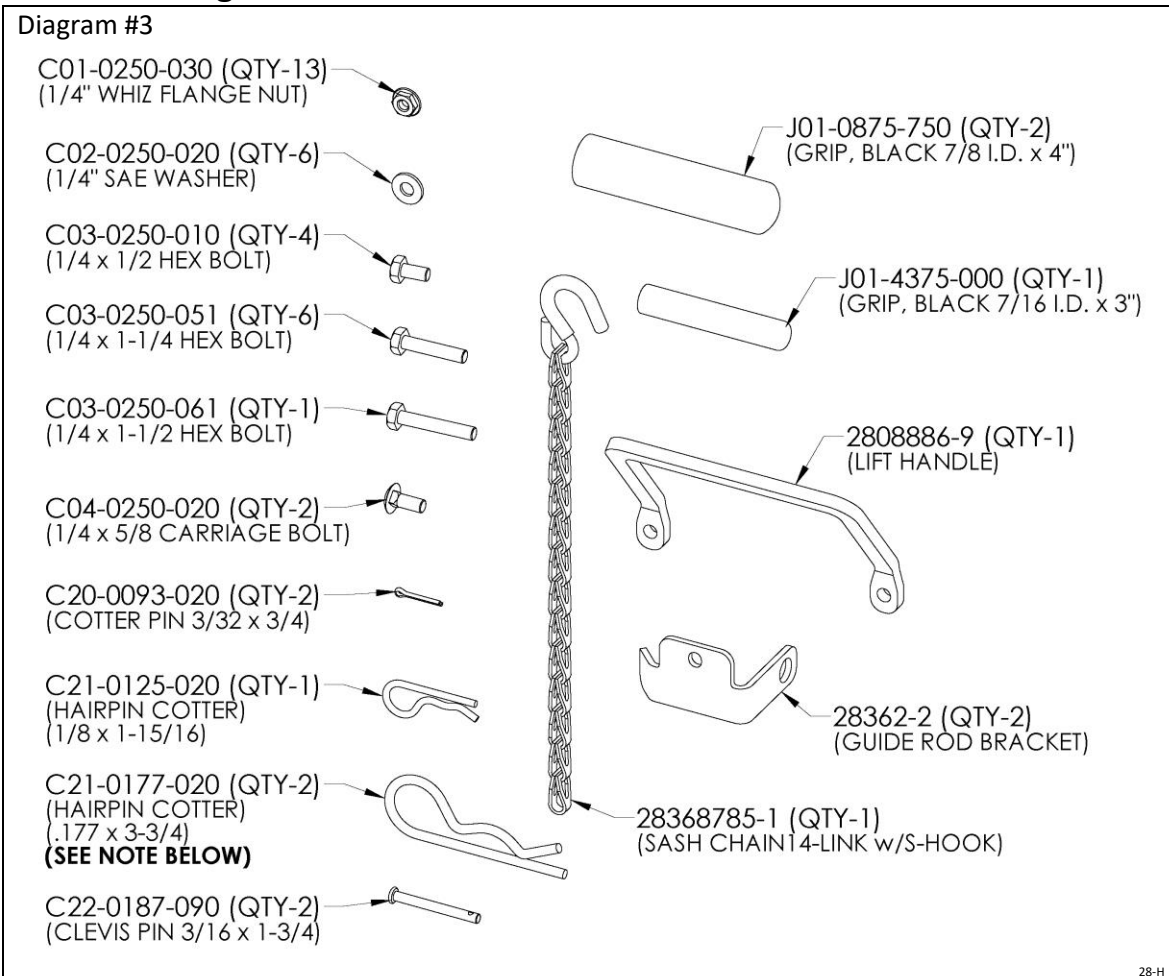

Note:

Part numbers C21-0177-020 (Qty-2) is not used in this spreader package.

36" Hopper Assembly Schematic

Diagram #4

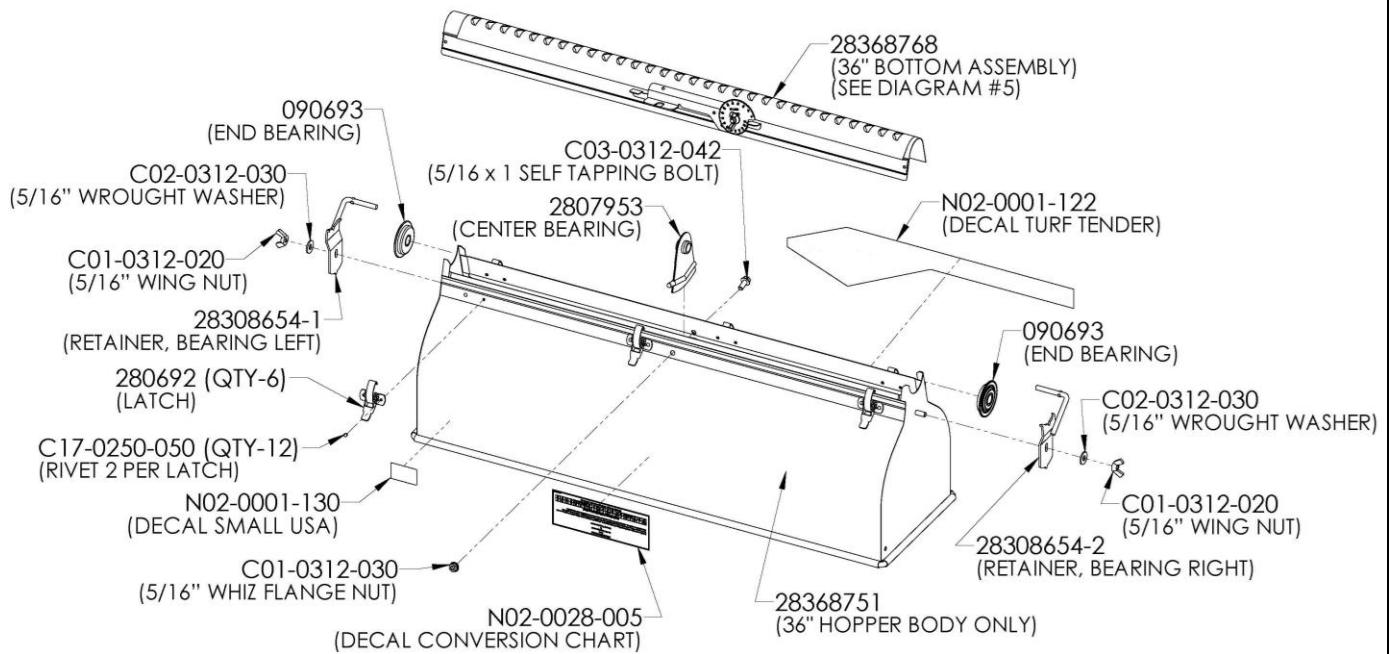

2836-A1

Bottom Assembly (28368768) Breakdown:

These parts are part of the Bottom Assembly but can be ordered separately.

Diagram #5

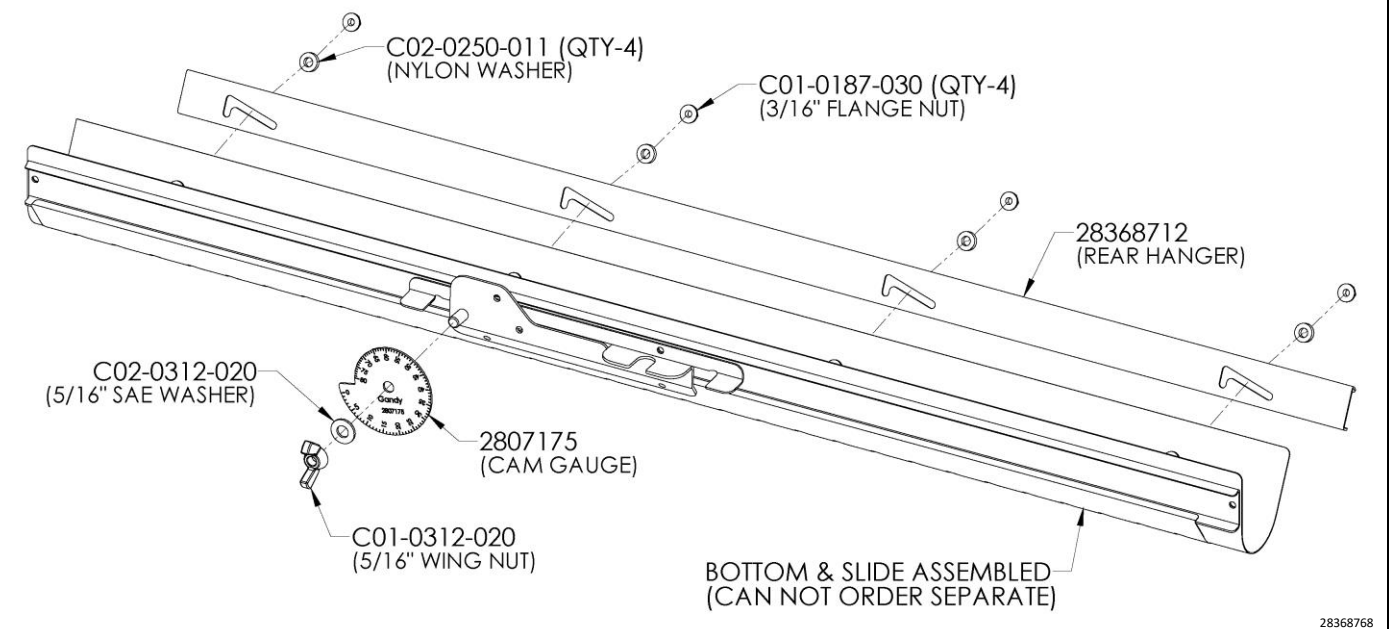

28368768

Assembly Instructions: (All Hardware & Small Parts in Hardware Bag Unless Otherwise Specified)

Please read and review all instructions before starting to assemble.

Minimum tools required.

Pliers, Two 7/16" Wrenches & One 1/2" Wrench

Step# 1 (Unpacking & Rotor Bar Assembly)

Remove contents from carton and check all parts against page #1 to confirm parts.

Un-wrap rotor bars, making sure one washer stays on each long end of rotor bar. See Diagram #2 on page #2

Carefully open the hardware bag and check all parts against page #2, Diagram #3 to confirm all parts.

1. **Note:** Lay something down (piece of cardboard or blanket) to protect hopper from being scratched up. Place hopper upside down with cam gauge facing you.
2. Un-snap latches on hopper (three each side) and un-hook from bottom assembly.
3. Remove bottom assembly from hopper by pulling straight up on it.
4. Remove the 5/16" wing nut and washer from each bearing retainer and remove both bearing retainers. Save the wing nuts & washer as they will be re-used latter.
5. Remove both bearings from hopper. (Note: Bearing may fall out when removing bearing retainers.)
6. Install rotor bars (short end of rotor bar) into center bearing.
7. Slide bearing onto rotor bar (long end) up to hopper, making sure washer is still on rotor bar. Repeat for other rotor bar. Make sure center bearing is standing straight up.
8. Install bottom assembly back onto hopper. Cam gauge will be on same side as the 5/16" threaded stud.
9. Make sure bearings are pushed into hopper, re-snap all six latches to hold bottom in place.
10. Re-install left side bearing re-using the 5/16" washer and wing nut to hold bearing retainer in place. When installing make sure the rod on the bearing retainer is on the opposite side of the cam gauge. Other bearing retainer will be re-installed in the next step.

Diagram #6

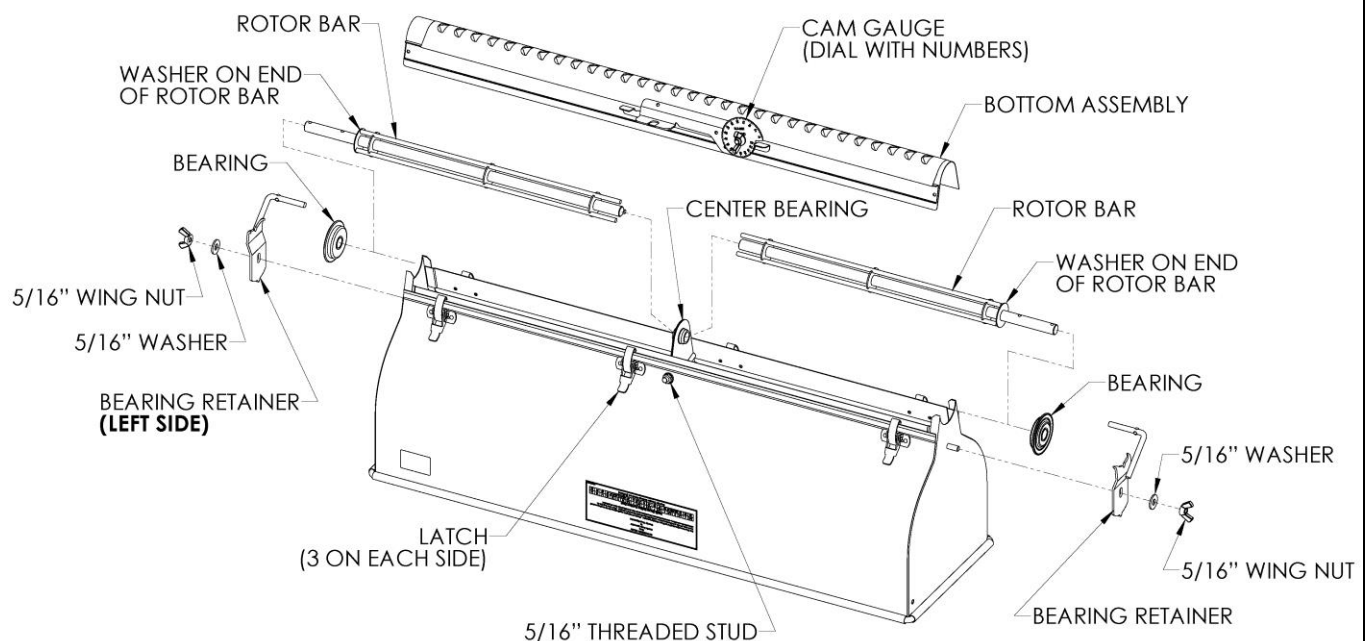

2836-A1

Step# 2 (Spread Plate Assembly)

1. Locate Spread Plate (2836878).
2. Slide rolled edge (side without bend) of spread plate onto bearing retainer rod as shown in Diagram #7.
3. Re-install the last bearing retainer to hopper and spread plate re-using the 5/16" washer and wing nut.
3. Adjust bearing retainers so spread plate can pivot freely. Tighten both 5/16" wing nuts securely.

Diagram #7

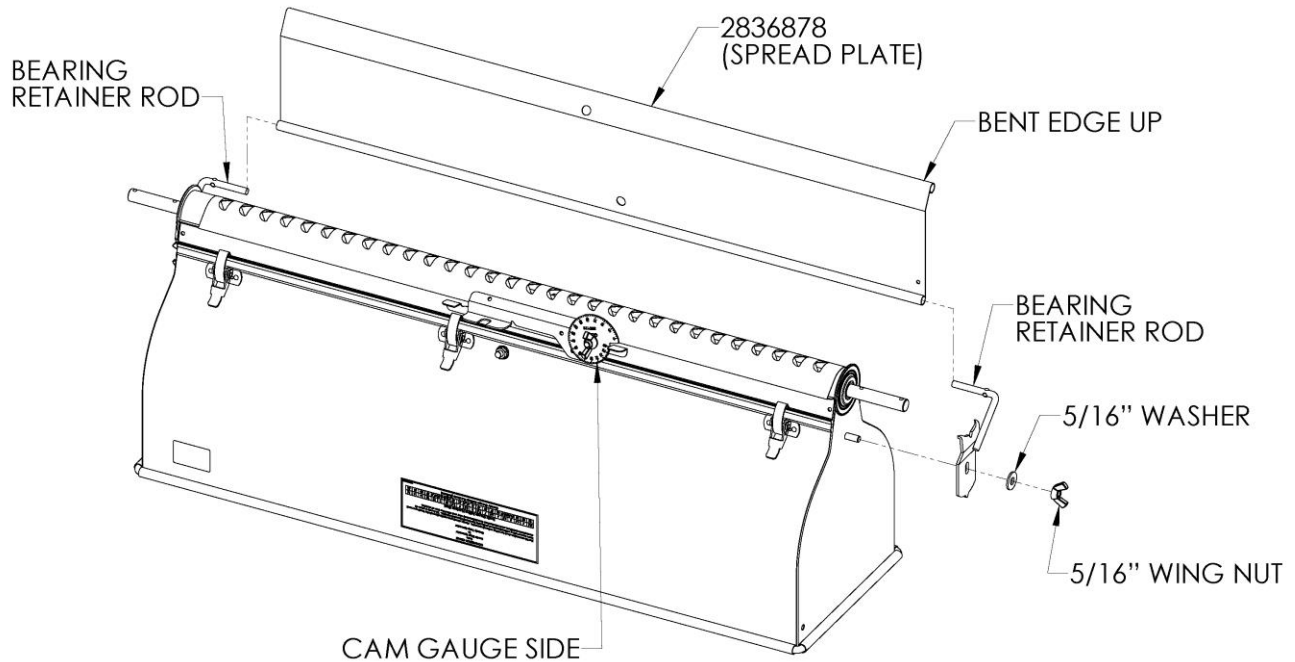

2836-A1

Step# 3 (Tire Assembly)

Install tire (R02-0013-000) to rotor bar shaft end using the 3/16 x 1-3/4 clevis pin (C22-0187-090) and 3/32 x 3/4 cotter pin (C20-0093-020). Pin tire to the hole in the rotor bar that is closest to hopper. Repeat for other tire.

Diagram #8

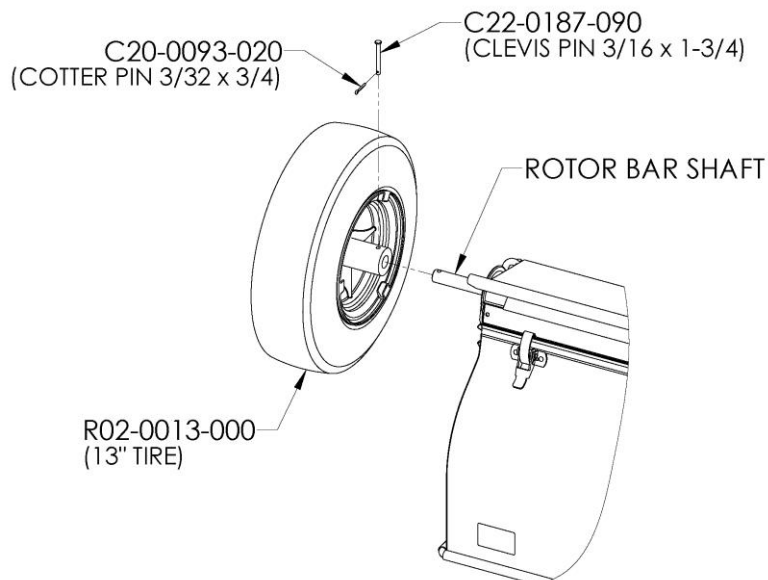

2836-A1

Step# 4 (Locate the Following Parts & Hardware)

Parts:

Mount Tube (28362-1)

Shut-Off Rod (28362-7)

Guide Rod Bracket (28362-2) (Qty-2)

Hardware:

1/4 x 1-1/4 Hex Bolts (C03-0250-051) (Qty-2)

1/4" Washers (C02-0250-020) (Qty-2)

1/4" Flange Nuts (C01-0250-030) (Qty-2)

Diagram #9

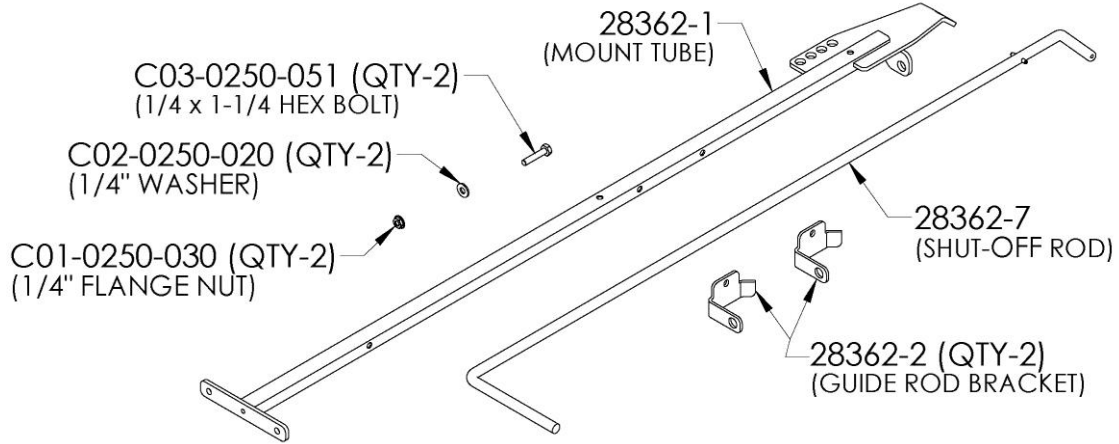

2836-A3

Step# 5 (Mount Tube & Shut-Off Lever Assembly)

1. Insert the 90° bent end of shut-off rod (28362-7) through guide tab on mount tube (28362-1) as shown in Diagram #10.
2. When 90° bend on shut-off rod hits the guide tab rotate the shut-off rod (see diagram #11) and slide shut-off rod until the spring pin touches the guide tab as shown in Diagram #12.

Diagram #10

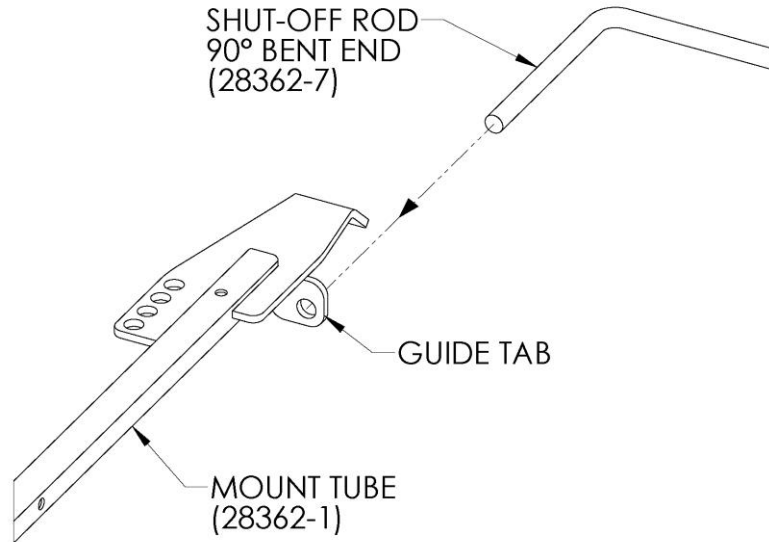

2836-A2

Diagram #11

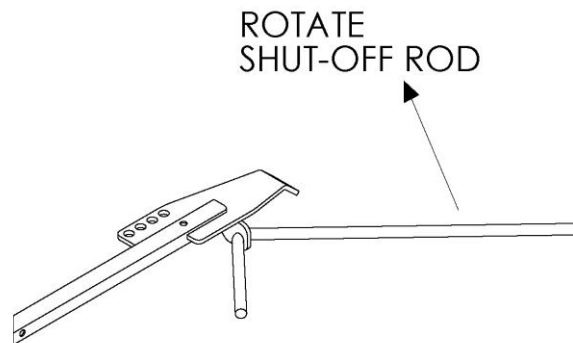

2836-A2-1

Diagram #12 (Installed View)

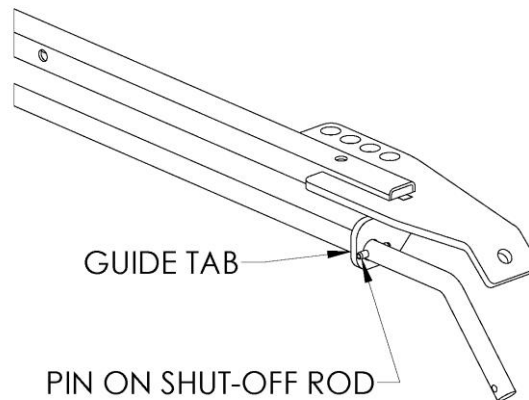

2836-A2-2

Step# 6 (First Guide Shut-Off Lever Assembly)

1. Slide the first guide rod bracket (28362-2) over the 90° bent end of the shut-off rod and rotate around the corner of the shut-off rod. Now slide guide all the way down the shut-off rod to the farthest hole down on the square tube. When in place the tab with small slot will be on the opposite side of the square tube as the shut-off rod as shown in Diagram #14.
2. Fasten the guide in place as shown in diagram #15 using the listed hardware. Do not tight bolt.

Diagram #13

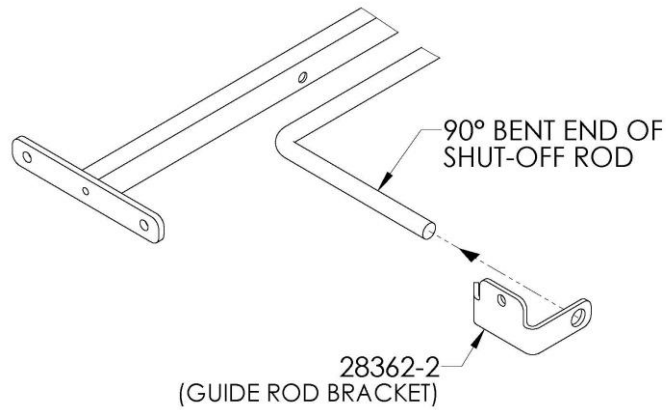

Diagram #14

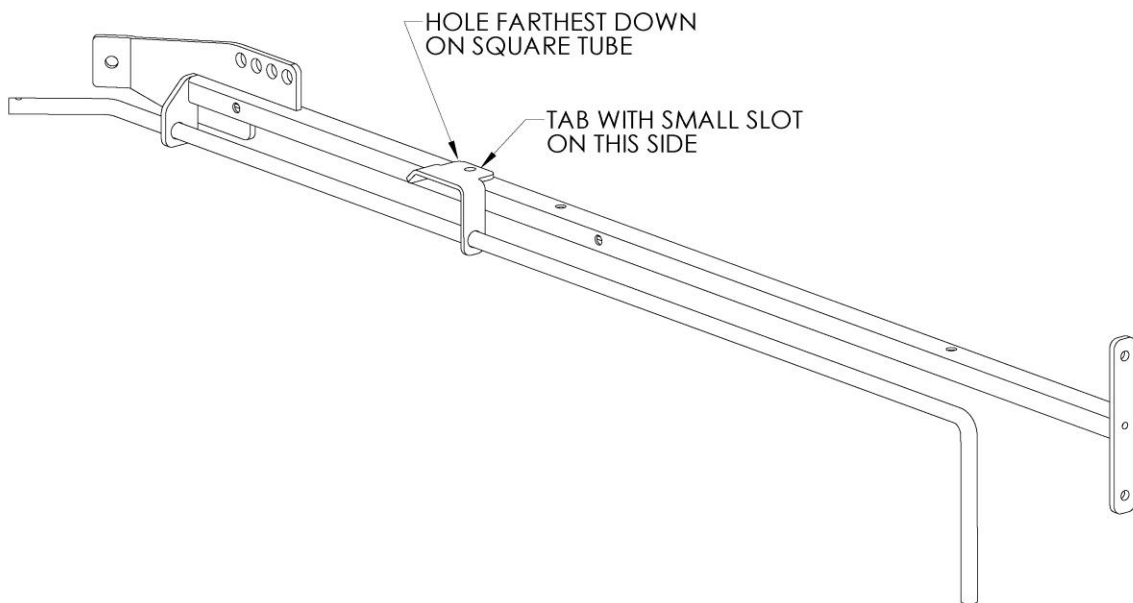
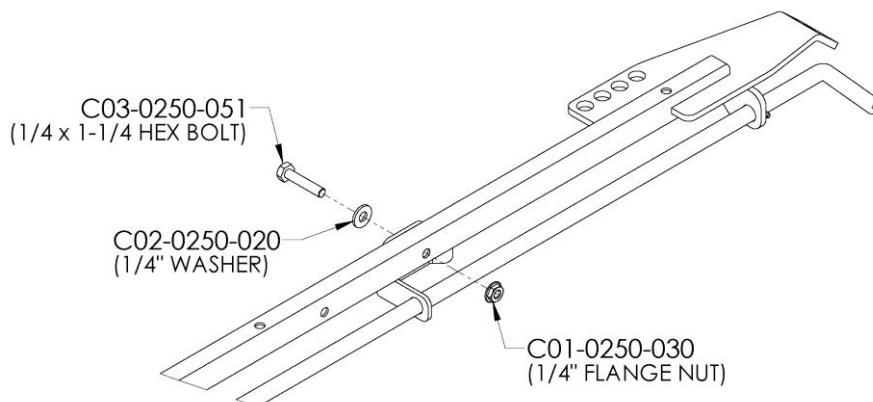

Diagram #15



2836-A12

Step#7 (Second Guide Shut-Off Lever Assembly)

1. Slide the second guide rod bracket (28362-2) over the 90° bent end of the shut-off rod and rotate around the corner of the shut-off rod to the top hole on the square tube. When in place the tab with small slot will be on the opposite side of the square tube as the shut-off rod as shown in Diagram #17.
2. Fasten the guide in place as shown in diagram #18 using the listed hardware.
Tighten hardware from this step & last step securely.

Diagram #16

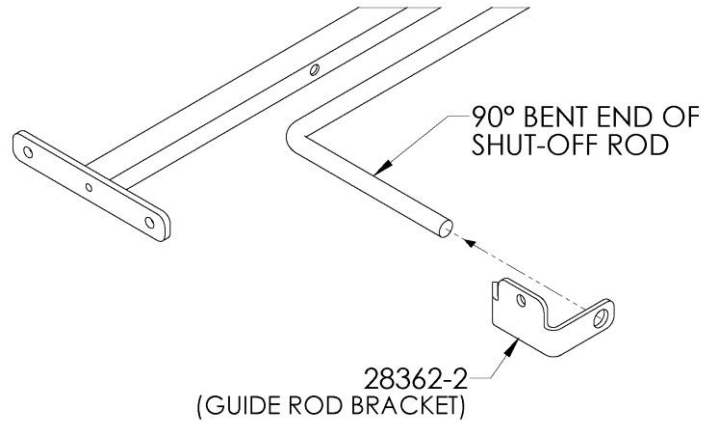

Diagram #17

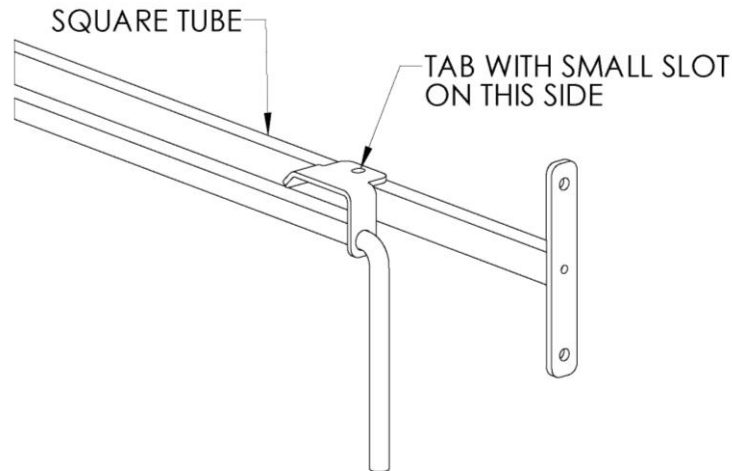
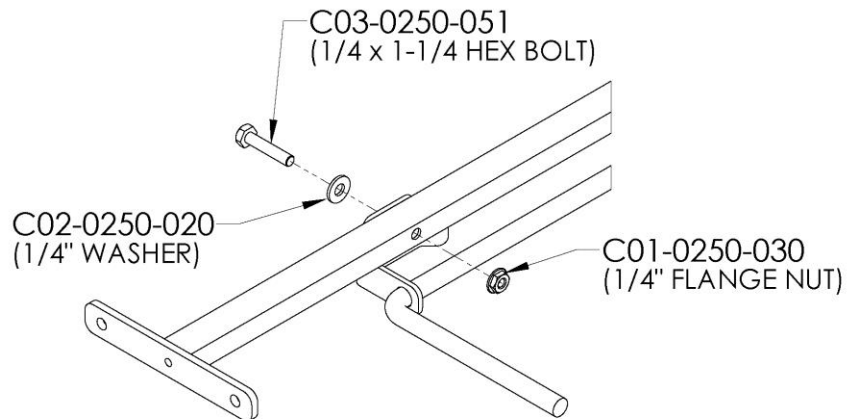

Diagram #18



2836-A4

Step# 8 (Mount Tube to Hopper Assembly)

1. **Note:** Lay something down (piece of cardboard or blanket) to protect hopper from being scratched up. Lay hopper on its side so the cam gauge is up & pivot the spread plate down out of the way as shown in Diagram #19.
2. Remove the 5/16" flange nut from the stud above and to the right of the cam gauge as shown in Diagram #19.
3. Attach the mount tube with shut-off rod in place to the 5/16" stud & re-use the 5/16" flange nut. Make sure the end of the shut-off lever goes into the U-notch as shown in Diagram #20.
Do not tighten, leave nut loose.

Diagram #19

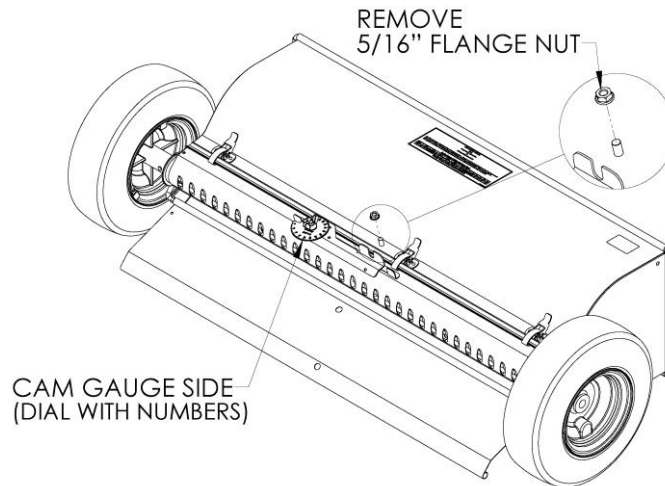
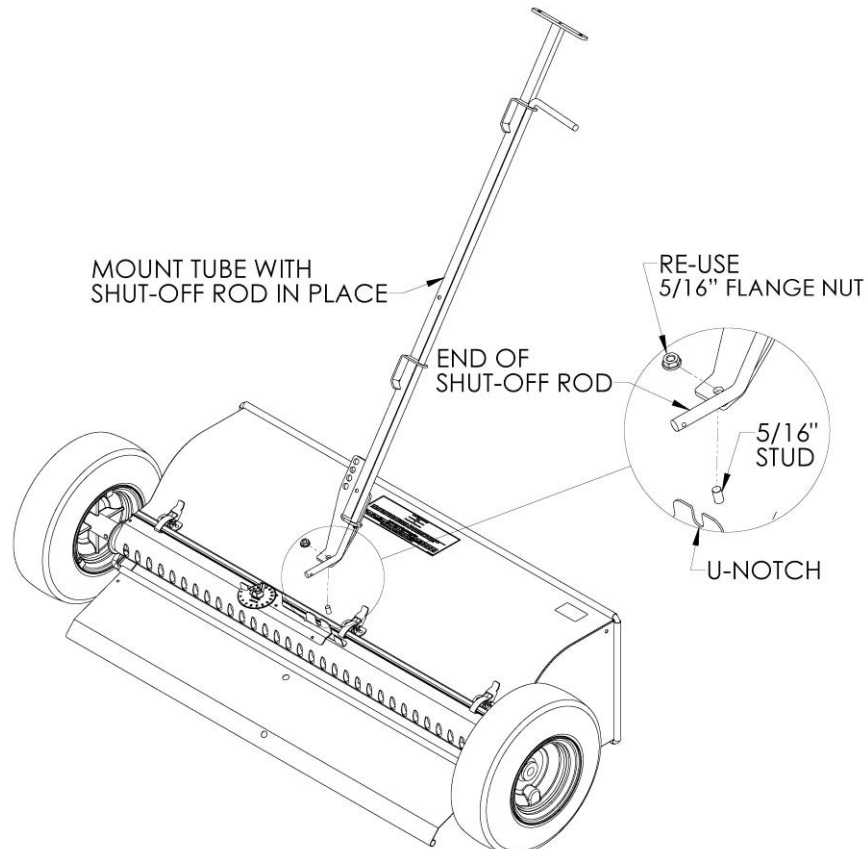

Diagram #20



Step #9 (Left Brace to Mount Tube Assembly)

1. Locate the TWO braces (28362-5), TWO 1/4 x 1/2 hex bolts (C03-0250-010), ONE 1/4 x 1-1/2 hex bolt (C03-0250-061), THREE 1/4" flange nuts (C01-0250-030) and ONE 1/4" washer (C02-0250-020).
2. Attach one end of the brace to the 1/4" hole in the left side of the hopper as shown in Diagram #21 using a 1/4 x 1/2 hex bolt and 1/4" flange nut as shown. Do not tighten bolt.
3. Attach the other end of the brace to the 1/4" hole in the side of mount tube using a 1/4" washer, 1/4 x 1-1/2 hex bolt and 1/4" flange nut. Do not tighten, leave loose.

Diagram #21

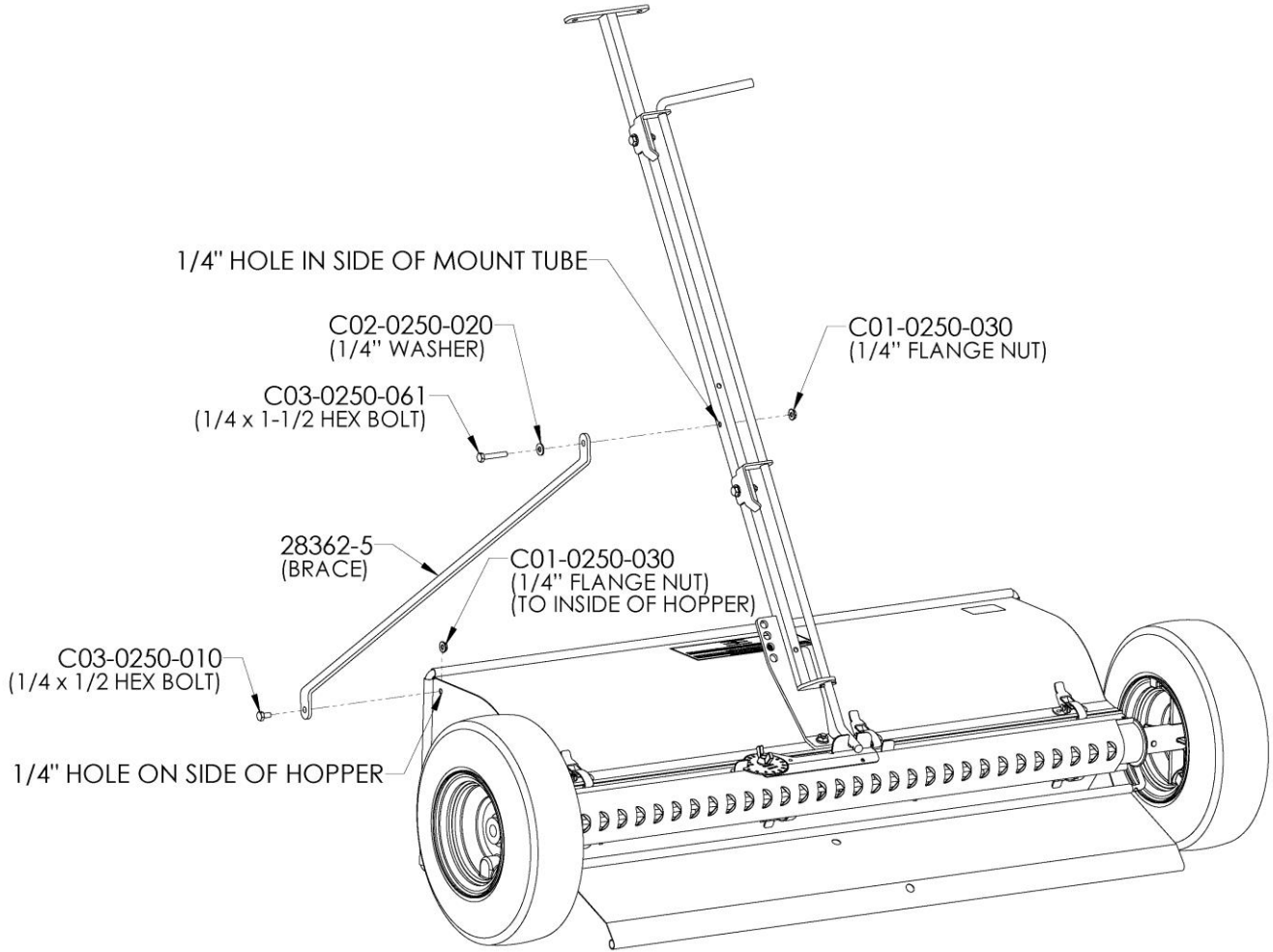

2836-A6

Step #10 (Right Handle Brace Assembly)

1. Attach the second brace (28362-5) to the 1/4" hole on the right side of the hopper using the 1/4 x 1/2 hex bolt and 1/4" flange nut. Do not tighten bolt.
2. Remove the 1/4" flange nut from the 1/4 x 1-1/2 bolt holding the left brace in place to the mount tube.
3. Attach the other end of the brace to the 1/4 x 1-1/2 bolt and re-install the 1/4" flange nut.
4. Next securely tighten the three 1/4" bolts holding the braces in place.
5. Now securely tighten the 5/16" flange nut holding the mount tube to the hopper.

Diagram #22

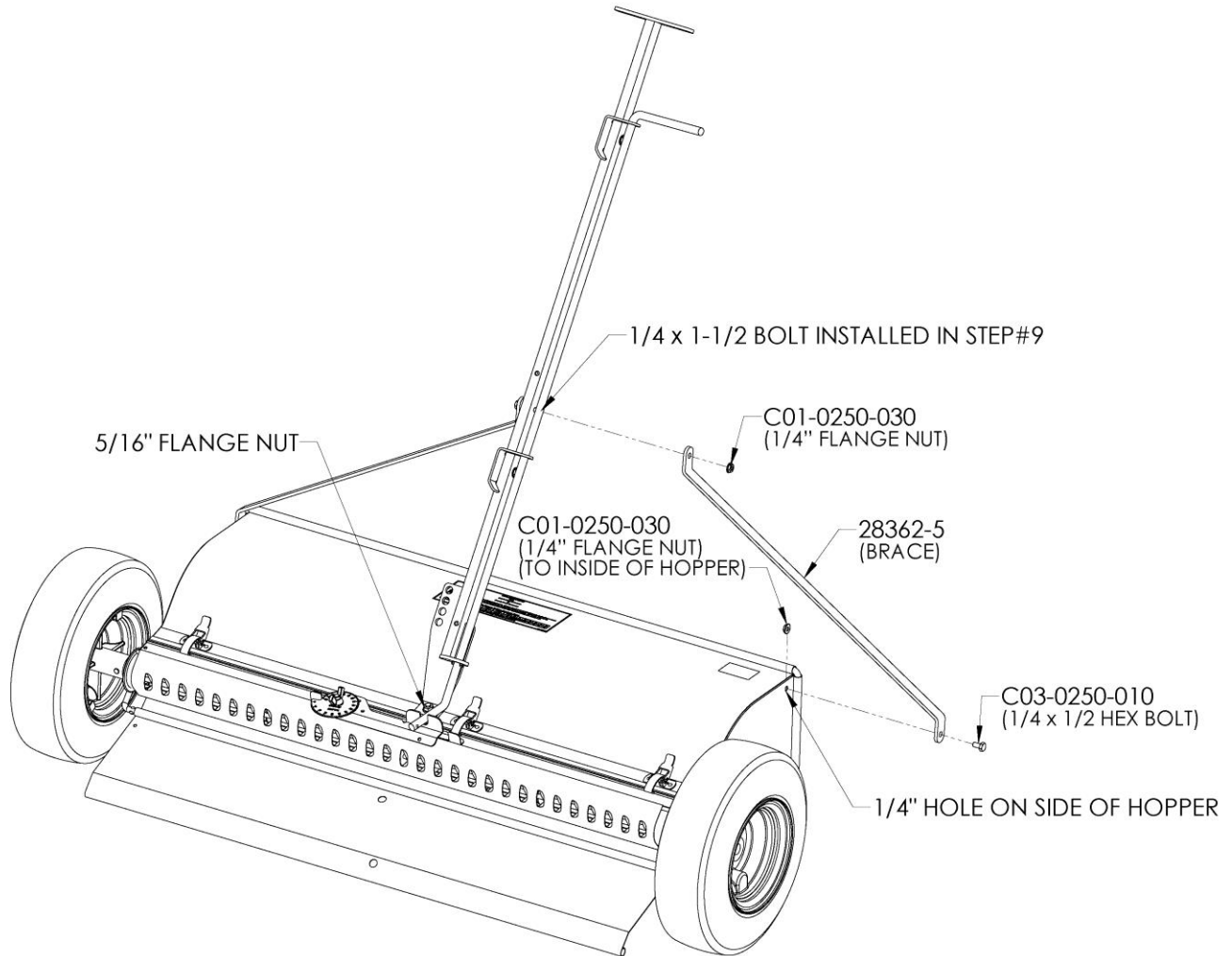

2836-A6

Step #11 (Parking Stand Assembly)

1. Locate the following parts: front parking stand (28362-4), back parking stand (28362-6), TWO 1/4 x 5/8 carriage bolts (C04-0250-020) and TWO 1/4" flange nuts (C01-0250-030) as shown in Diagram #23.
2. Fasten parking stands together using two carriage bolts and flange nuts as shown in Diagram #23. Do not tighten, Leave loose.

Diagram #23

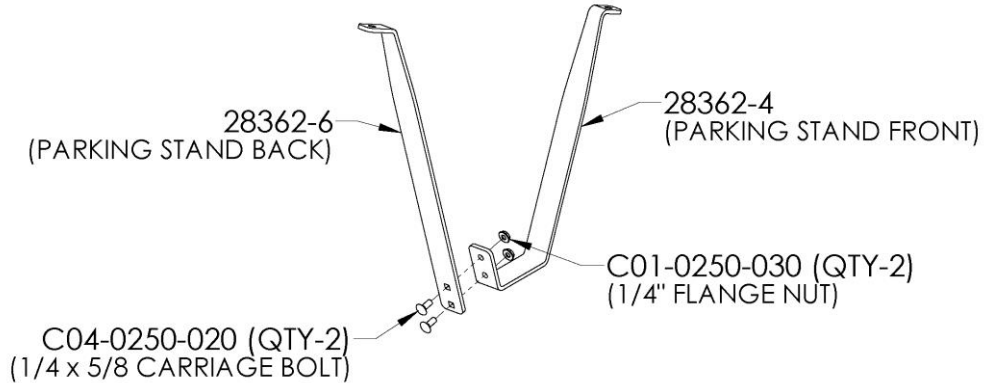

2836-A7

Step #12 (Parking Stand to Mount Tube Assembly)

1. Locate TWO 1/4 x 1-1/4 hex bolts (C03-0250-051), TWO 1/4" washers (C02-0250-020) and TWO 1/4" flange nuts (C01-0250-030).
2. Attach the long end of the parking stand to the top 1/4" hole in the mount tube using a 1/4 x 1-1/4 hex bolt, 1/4" washer and 1/4" flange nut as shown in Diagram #24. Do not tighten.
3. Attach the other end of the parking stand to the bottom 1/4" hole in the mount tube using the same hardware as shown in Diagram #24. Do not tighten.
4. Securely tighten the two carriage bolts from last step first and then then securely tighten the two bolts from this step.

Diagram #24

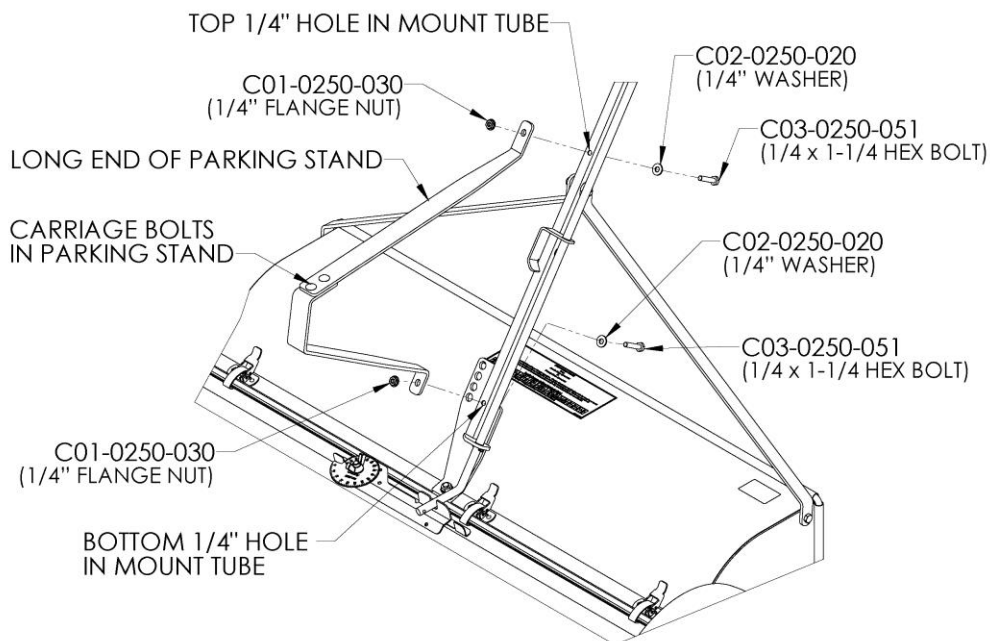

2836-A8

Step #13 (Sash Chain to Spread Plate Assembly)

1. Locate Sash Chain (28368785-1) and the small hairpin cotter 1/8 x 1-15/16 (C21-0125-020).
2. Insert sash chain into hole in spread plate as shown in Diagram #25.
3. Connect the small hairpin cotter to the bottom most link on the sash chain.
4. Pull sash chain up so the hairpin cotter contacts the spread plate.

Diagram #25

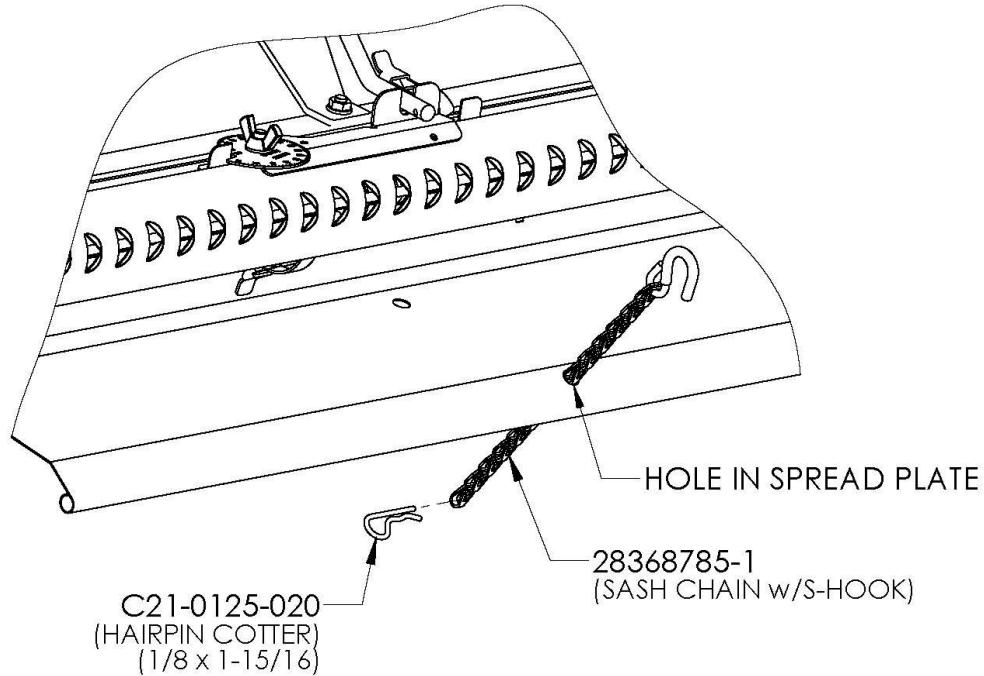

2836-A9

Step #14 (Connect Sash Chain to Handle)

Turn spreader upright so it sits up on its wheels and parking stand.

Pivot spread plate towards the hitch; then connect the S-Hook on the sash chain to the second hole up from the hopper on the mount plate as shown in Diagram #26.

Diagram #26

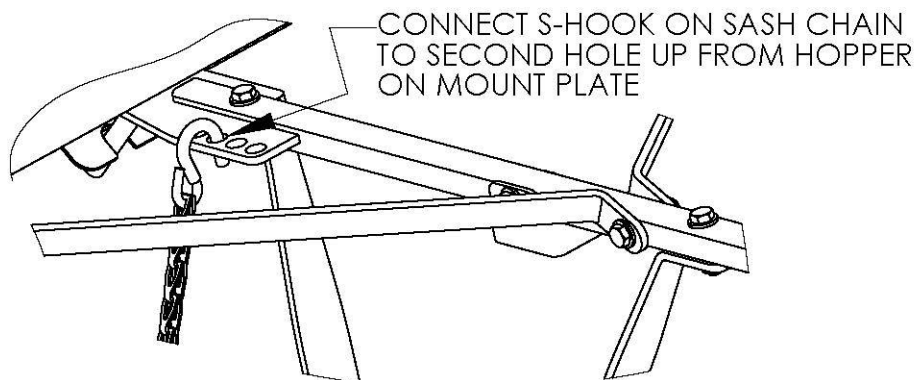

2836-A9

Step #15 (Handle Tube Assembly)

1. Locate the following parts: Handle Tube (28362-3), TWO 1/4 x 1-1/4 hex bolts (C03-0250-051), TWO 1/4" washers (C02-0250-020) and TWO 1/4" flange nuts (C01-0250-030).
2. Attach the Handle Tube to the Mount Tube using the above listed hardware as shown in Diagram #27. Tighten hardware securely.

Diagram #27

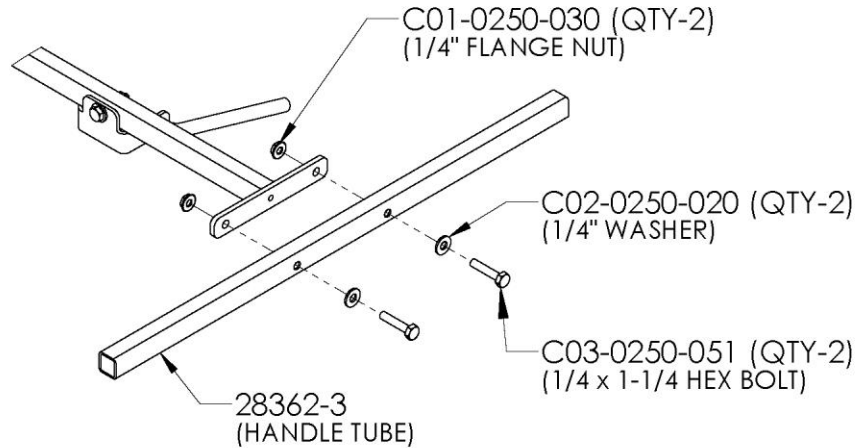

2836-A10

Step #16 (Grip Assembly)

- Locate the two large grips and the small grip.
Push the small grip on the Shut-Off Rod as shown.
Push the large grip, one on each end of the Handle Tube as shown.

Diagram #28

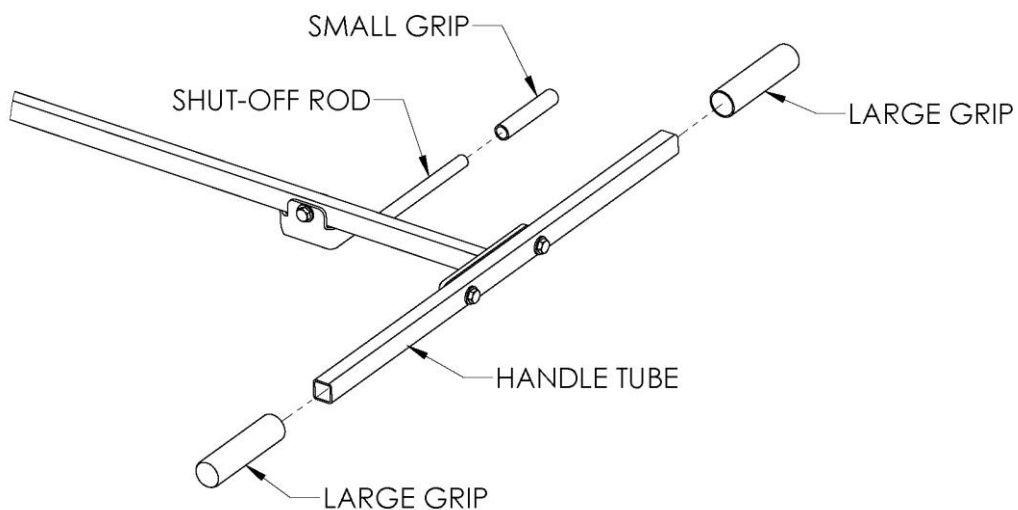

2836-A11

Step #17 (Lift Handle Assembly)

1. Locate Lift Handle (2808886-9), TWO 1/4 x 1/2 hex bolts (C03-0250-010) and TWO 1/4" flange nuts (C01-0250-030).
2. Attach Lift Handle to the two 1/4" hole in the front of the hopper using the above listed hardware as shown in Diagram #29. Tighten hardware securely.

Diagram #29

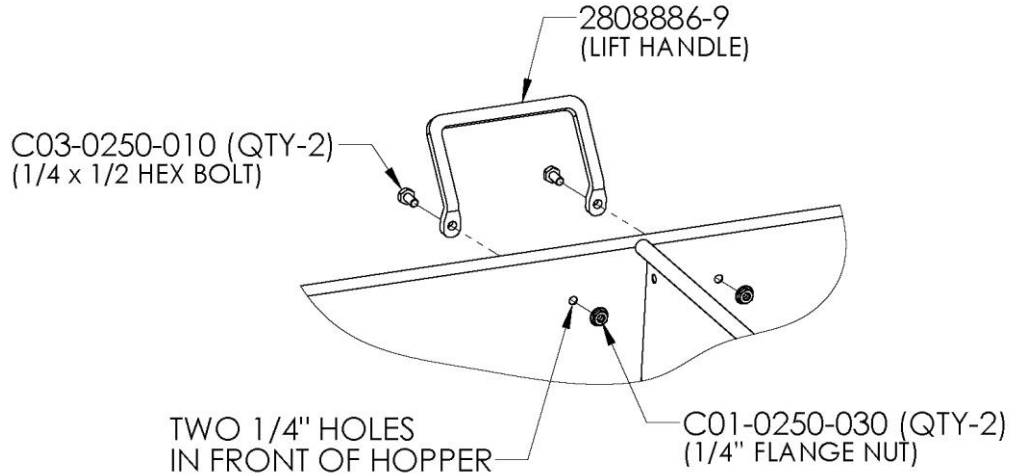

2836-A11

18. Spread Plate Adjustment:

As shown in Step #14 Diagram #26, connecting the spread plate chain to the second hole up from the hopper on the mount tube plate is a good starting point for most material being applied to produce a "Sheet-Like" flow coming off the spread plate.

Depending on your application rate and weight of the product being applied you may need to adjust the angle up or down so the material flows freely off the spread plate.

If application without spread plate is desired, lift spreader up and swing spread plate to the lift handle side of the spreader and hook the s-hook on the sash chain over the lip on the spreader.

See operator's manual for more information.

19. Please read Operators Manual for overview of proper use, maintenance & cleaning of spreader.

36" Spreader Parts Breakdown:

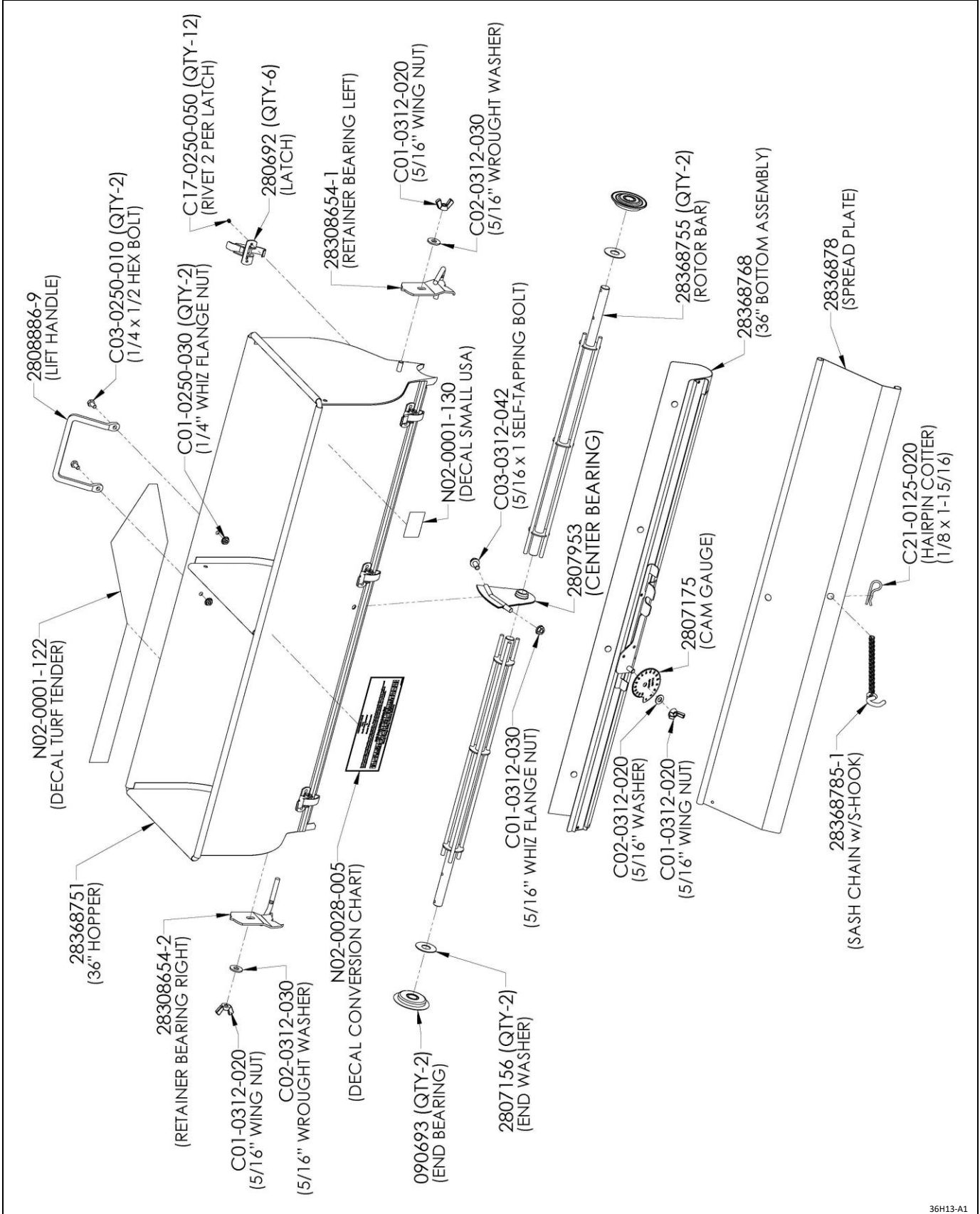

36H13-A1

36" Push Handle Parts Breakdown:

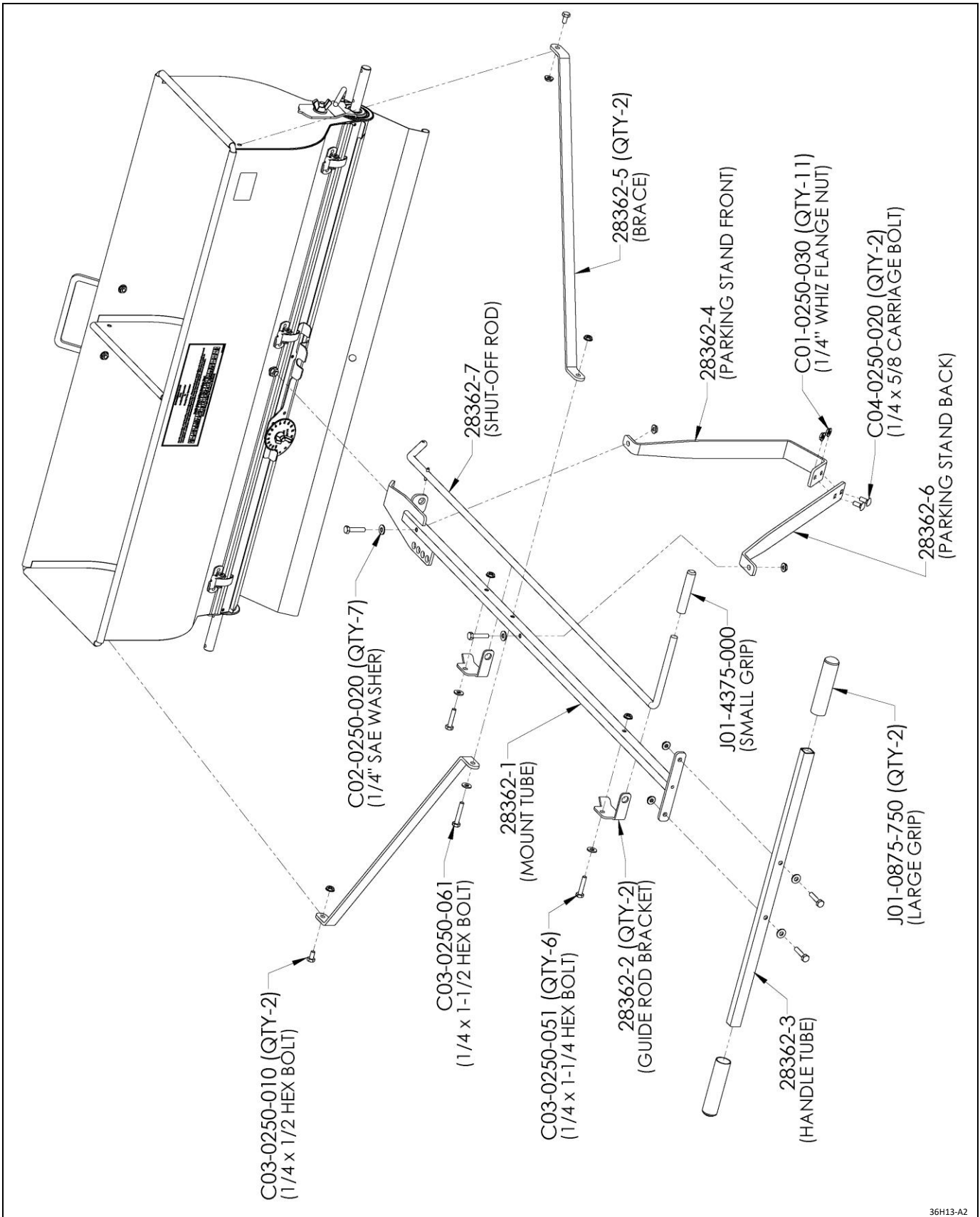

36H13-A2

13" Pneumatic Tire & Mount Hardware:

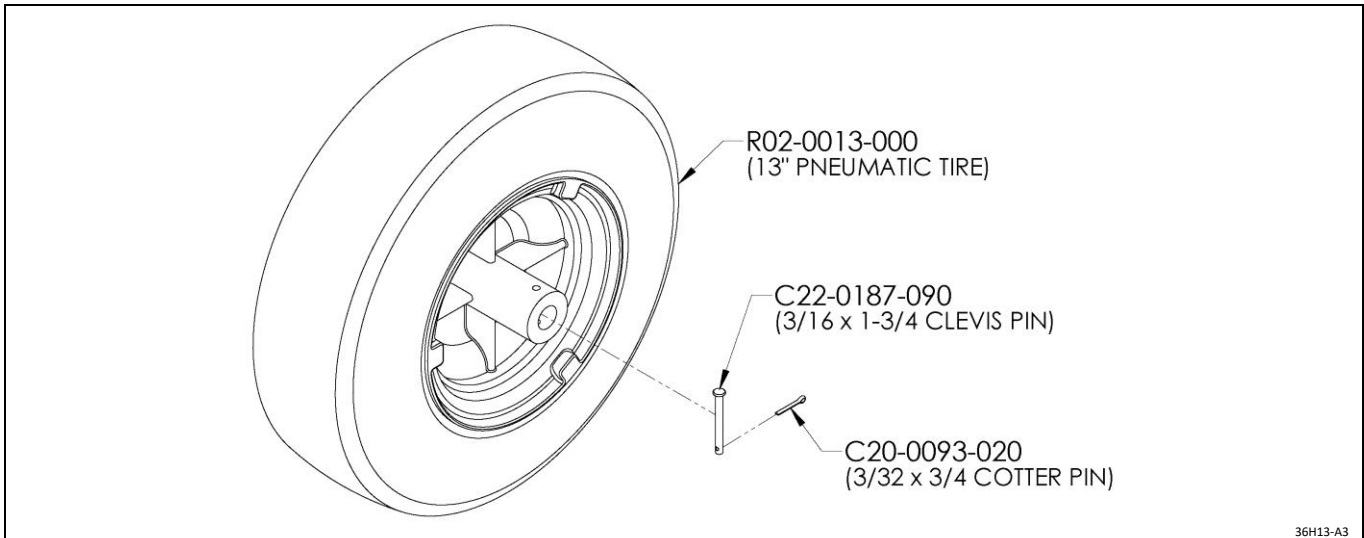

Optional Equipment (NOT Part of Spreader Package)

Calibration Pan & Mounting Hardware: Package #28368584

Calibration pan hangs under the spreader to catch material to double check application rates.

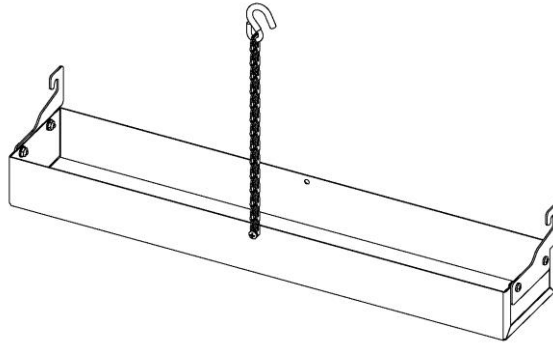

Jiggler Package: Package #J36

Use Jigglers on bridging material.

When installed Jigglers contact the rotor bar and move up and down to help maintain an even material flow.

