



Illustrated Parts and Packing List & Instructions

815 Rice Lake Street, Owatonna, MN 55060

Phone: 800-443-2476 / 507-451-5430

www.gandy.net / Email: sales@gandy.net

623116C-S

Orbit-Air Applicator

Implement Mounted Hopper

**31 Cu. Ft. (.88m³), 24.8 Bushel, 1395-Lb Chemical Capacity,
w/ 16 (1-1/4") Openings, Chemical (C) Black Wheels**

For Use w/ 1" I.D. Tubing

Split Shaft, Two Clutches

(All Parts & Hardware in Place Unless Otherwise Specified)

- 1..... S02-0001-034.....Shipping Crate (23/31 CF Hopper)
Use: 4 Hex Bolt (3/8 x 2-3/4) (C03-0375-111)
8 Wrought Washer (3/8) (C02-0375-030)
4 Hex Nut (3/8) (C01-0375-010)
- 1..... 62240-1B.....Hopper, 23/31 CF (Painted Black)
Use: 2 Sight Window (610851/26)
4 Rail (610851/27)
12 Pop Rivet (3/16 x 3/8) (C19-0187-030)
1 Decal, Important, Metering Wheel (N02-0062-040)
2 Decal, Caution (N02-0014-010)
1 Decal, Caution Black on Yellow (N02-0062-050)
1 Decal, Caution Plug (N02-0062-051)
- 1..... 62241-1.....Roof 31 CF
Use: 2 Carriage Bolt (3/8 x 1-1/2) (C04-0375-061)
2 Wrought Washer (3/8) (C02-0375-030)
2 Whiz Flange Nut (3/8) (C01-0375-030)
20 Carriage Bolt (5/16 x 3/4) (C04-0312-031)
20 Whiz Flange Nut (5/16) (C01-0312-030)
2 Decal, Orbit-Air Small (N02-0001-123)
- 2..... 62240-4.....Bushing Mount
Use: 2 Carriage Bolt (3/8 x 2) (C04-0375-080)
2 Whiz Flange Nut (3/8) (C01-0375-030)
- 2..... 62200-22.....Screen Support Bracket
Use: 4 Carriage Bolt (5/16 x 3/4) (C04-0312-031)
4 Whiz Flange Nut (5/16) (C01-0312-030)
- 1..... 62240-3.....Cover (For 23/31 CF)
Use: 2 Carriage Bolt (3/8 x 1-1/4) (C04-0375-051)
2 Wrought Washer (3/8) (C02-0375-030)
2 Jam Lock Nut (3/8) (C01-0375-062)
- 1..... M05-0000-004.....Rubber Latch w/ Keeper
Use: 4 Pop Rivet (C19-0187-000)

- 2..... 62852-3..... Inner Hinge (Cover)
 Use: 2 Hex Bolt (3/8 x 1) (C03-0375-041)
 4 Jam Nut, Nylon Lock (3/8) (C01-0375-062)
 8 Wrought Washer (3/8) (C02-0375-030)
- 2..... 62852-4..... Outer Hinge (Cover)
 Use: 8 Wrought Washers (3/8) (C02-0375-030)
 4 Jam Nut, Nylon Lock (3/8) (C01-0375-062)
- 2..... 629069-1..... Mounting Base, w/ Holes
 Use: 16 Hex Bolt (3/8 x 1-1/4) (C03-0375-051)
 16 Wrought Washer (3/8) (C02-0375-030)
 16 Lock Washer (3/8) (C02-0375-010)
 16 Whiz Flange Nut (3/8) (C01-0375-030)
- 2..... 629066-8..... Shaft, Gear & Driven Sprocket (22-1/2 x 5/8 Round)
 3..... 63861-7..... Bearing, Plastic (For 5/8 Shaft)
 6..... 09074690-4..... Flangette, Bearing (For Bearing 63861-7)
 Use: 6 Carriage Bolt (1/4 x 5/8) (C04-0250-020)
 6 Whiz Flange Nut (1/4) (C01-0250-030)
- 2..... 628957-1..... Shaft Sensor w/ Tabs
 2..... 62240-11..... Bracket Sensor
 Use: 4 Hex Bolt (1/4 x 1/2) (C03-0250-010)
 4 Lock Washers (1/4) (C02-0250-010)
 4 Whiz Flange Nut (1/4) (C01-0250-030)
- 2..... 62240-12..... Mount Sensor
 Use: 2 Carriage Bolt (1/4 x 5/8) (C04-0250-020)
 2 Whiz Flange Nut (1/4) (C01-0250-030)
- 2..... 62851-42..... Chain Sprocket, 21-Tooth (5/8 Bore)
 Use: 2 Cotter Pin (3/16 x 1-1/4) (C20-0187-030)
- 2..... 62853-9..... Sprocket, 24-Tooth (5/8 Bore x 1-3/8 Hub)
 Use: 2 Cotter Pin (3/16 x 1-1/4) (C20-0187-030)
- 1..... 629066-14..... Shaft (49-11/16 x 1-inch Round)
 2..... D05-1000-010 Bearing (For 1-inch Shaft)
 Use: 4 Hex Bolt (5/16 x 3/4) (C03-0312-030)
 4 Lock Washer (5/16) (C02-0312-010)
 4 Hex Nut (5/16) (C01-0312-010)
- 2..... 628720-7..... Bushing (1-1/4 O.D. x 1-1/8 Long)
 2..... 62240-13..... Bracket, Clutch Mount (For 23/31 CF Hopper)
 Use: 4 Hex Bolt (5/16 x 3/4) (C03-0312-030)
 4 Lock Washer (5/16) (C02-0312-010)
 4 Whiz Flange Nut (5/16) (C01-0312-030)
- 2..... 62853-10..... Chain Sprocket 32-Tooth (One Bolted To Each Clutch)
 Use: 8 Hex Bolt (1/4 x 3/4) (C03-0250-030)
 8 Whiz Flange Nut (1/4) (C01-0250-030)
- 1..... 62853-12..... Electric Clutch w/ 35-Tooth Sprocket
 Use: 1 Cable-Tie (3/16 x 4) (L04-0001-000)
 1 Hex Bolt (3/8 x 1) (C03-0375-041)
 3 Wrought Washer (3/8) (C02-0375-030)
 1 Lock Washer (3/8) (C02-0375-010)
 1 Whiz Flange Nut (3/8) (C01-0375-030)

- 1..... L05-0010-001Electric Clutch
 Use: 1 Cable-Tie (3/16 x 4) (L04-0001-000)
 1 Hex Bolt (3/8 x 1) (C03-0375-041)
 3 Wrought Washer (3/8) (C02-0375-030)
 1 Lock Washer (3/8) (C02-0375-010)
 1 Whiz Flange Nut (3/8) (C01-0375-030)
- 2..... 62854-29.....Washer, Electric Clutch
 Use: 2 Hex Bolt (5/16 x 3/4) (C03-0312-030)
 2 Lock Washer (5/16) (C02-0312-010)
- 1..... G06-0060-001Speed Control (Zero Max **Y42**)
 Use: 4 Hex Bolt (3/8 x 1-1/4) (C03-0375-051)
 4 Wrought Washer (3/8) (C02-0375-030)
 4 Lock Washer (3/8) (C02-0375-010)
 4 Whiz Flange Nut (3/8) (C01-0375-030)
- 1..... 62853-43.....Sprocket, 16-Tooth (5/8 Bore x 1-3/4 Hub) (On Zero-Max)
 Use: 2 Socket Set Screw (#10-24 x 5/16) (C06-0187-030)
- 1..... 62853-44.....Sprocket, 16-Tooth (1/2 Bore x 1-3/8 Hub) (On Zero-Max)
 Use: 2 Socket Set Screw (1/4 x 1/4) (C06-0250-020)
- 1..... F02-0041-100Roller Chain #41 (100 Rollers)
 Use: 1 Connector Link #41 (F02-0041-001)
- 1..... 62851-23.....Nylon Roller (Chain Tightener)
 Use: 1 Bushing (9/16 O.D. x 1-5/8 Long) (09065168-11)
 1 Carriage Bolt (3/8 x 2-1/2) (C04-0375-100)
 2 Wrought Washer (3/8) (C02-0375-030)
 1 SAE Washer (1/2) (C02-0500-020)
 1 Lock Washer (3/8) (C02-0375-010)
 1 Hex Nut (3/8) (C01-0375-010)
- 1..... 62851-8.....Air Chamber, 23/31 CF (16-outlet)
 Use: 2 Hex Bolt (3/8 x 1) (C03-0375-041)
 5 Hex Bolt (3/8 x 1-1/4) (C03-0375-051)
 5 Wrought Washer (3/8) (C02-0375-030)
 5 Lock Washer (3/8) (C02-0375-010)
 7 Whiz Flange Nut (3/8) (C01-0375-030)
- 1..... 629066-D.....Air Pressure Switch Wiring Assembly:
 Use: 2 Pan Head TC Screw (#8 x 1/2) (C07-0164-070)
- 1..... 5508242-33.....Gasket, Potting Box
- 1..... L10-0016-010.....Potting Box
 Use: 2 Pan Head TC Screw (#8 x 1/2) (C07-0164-070)
- 16..... M05-0829-300.....Gasket, Mixing Chambers
- 16..... M10-0055-000.....Mixing Chamber (For 1-inch I.D. Tubing)
 Use: 32 Hex Head Self-Tap Bolt (5/16 x 3/4) (C03-0312-032)
- 2..... M05-2000-000.....Rubber Plug, 2-inch (For Air Chamber Clean Out)
- 1..... 62851-32.....Angle Support, For Air Chamber & Blower
- 1..... 628720-18.....Clean-Out Chute, 4-in
 Use: 1 Wing Nut (5/16) (C01-0312-020)
 1 Wrought Washer (5/16)(C02-0312-030)
- 1..... M05-3000-000.....Rubber Plug, 3-inch (Hopper Clean Out)
- 1..... 62240-10.....Angle Clamp Tube Support (For 23/31 CF)
 Use: 4 Foam Clamp Strip 9-1/2 Long (62851-16)
 5 Hex Bolt (5/16 x 2-1/4) (C03-0312-091)
 5 Lock Nut, Nylon (5/16) (C01-0312-040)
- 1..... 5608226.....Bar Clamp, Plastic Tubing (For 23/31 CF)
 Use: 4 Foam Clamp Strip 9-1/2 Long (62851-16)

- 2..... 62852-16..... Mounting Bracket, Platform (23/31 CF)
Use: 4 Carriage Bolt (5/16 x 3/4) (C04-0312-031)
4 Whiz Flange Nut (5/16) (C01-0312-030)
- 1..... 62851-10..... Platform (For 23/31 CF)
Use: 3 Grip Tape (3 x 48-1/2 Long) (62851-15)
- 1..... 62851-37..... Angle Support (For 23/31 CF Hopper Platform)
Use: 4 Carriage Bolt (5/16 x 3/4) (C04-0312-031)
4 Whiz Flange Nut (5/16) (C01-0312-030)
- 1..... 62851-67..... Clear Windshield (For 23/31 CF Hopper)
Use: 6 Hex Bolt (1/4 x 5/8) (C03-0250-020)
6 Wrought Washer (5/16) (C02-0312-030)
6 Whiz Flange Nut (1/4) (C01-0250-030)
- 4..... 62851-5..... Screen (For 23/31 CF)
- 1..... 62240-8..... Bracket Long Fan Support
Use: 2 Hex Bolt (3/8 x 1-1/4) (C03-0375-051)
2 Wrought Washer (3/8) (C02-0375-030)
2 Lock Washer (3/8) (C02-0375-010)
2 Whiz Flange Nut (3/8) (C01-0375-030)
- 1..... 62240-9..... Bracket Short Fan Support
Use: 2 Hex Bolt (3/8 x 1-1/4) (C03-0375-051)
2 Wrought Washer (3/8) (C02-0375-030)
2 Lock Washer (3/8) (C02-0375-010)
2 Whiz Flange Nut (3/8) (C01-0375-030)

1..... **Jack Shaft Assembly 62240-J**

- 1..... **62200-23..... Drive Bearing Housing**
Use: 1 Carriage Bolt (3/8 x 1-1/4) (C04-0375-051) (Not Part of 62240-D)
1 Wrought Washer (3/8) (C02-0375-030) (Not Part of 62240-D)
1 Lock Washer (3/8) (C02-0375-010) (Not Part of 62240-D)
1 Hex Nut (3/8) (C01-0375-010) (Not Part of 62240-D)
- 2..... D05-1000-050 Bearing 1-inch Bore w/Set Screw
Use: 4 Hex Bolt (5/16 x 3/4) (C03-0312-030)
4 Lock Washer (5/16) (C02-0312-010)
- 1..... 629069-2..... Drive Shaft (1-inch x 10" Long)
Use: 2 SAE Washer (1-inch) (C02-1000-020)
1 Cotter Pin (3/16 x 1-1/2) (C20-0187-040)
- 1..... 62851-33..... Bushing (1-1/4 x 9/16 Long)
- 1..... 62853-13..... Sprocket, 24-Tooth (1-inch Bore x 1-1/2 Hub)
Use: 1 Cotter Pin (3/16 x 1-1/2) (C20-0187-040)

-
- 1..... F02-0041-062 Roller Chain #41 (62 Rollers) (Connect Jack Shaft to Zero-Max)
Use: 1 Connector Link #41 (F02-0041-001)

2..... 5508442-35.....Magnetic Hub, 5/8 Bore (**Installed on Metering Door Shaft**)
Use: 2 Spring Pin (3/16 x 1) (C23-0187-140)

1..... 629066-A.....Metering Door Assembly, 16 (1-1/4) Black Wheels Split Shaft:

1 62851-24.....Meter Door, 16-Out
Use: 2 J-Bolt (5/16) (C16-0312-020)
2 Wrought Washer (5/16) (C02-0312-020)
2 Wing Nut (5/16) (C01-0312-020)

4 Ft M05-0125-050.....Rubber Strip w/ Adhesive (1/8 x 1/2)

16 M10-0001-100.....Metering Cup, 1-1/4
Use: 36 Whiz Flange Nut (3/16) (C01-0187-030)

16 62851-76.....Hole Closures, Slotted
Use: 16 Comp Spring (E00-0420-012)
16 Extruded Washer (628720-20)
16 SAE Washer (5/16) (C02-0312-020)
16 Hex Bolt (5/16 x 1-3/4 **Stainless**) (C03-0312-071)

16 62851-75.....Metering Wheel Black w/ Inserts

32 62851-72.....Wear Plate, Stainless

2 629066-7.....Shaft (21-7/16 x 5/8 Hex)

3 63861-7.....Bearing, Plastic (5/8 Bore)

6 09074690-4.....Flangette, Bearing (For 63861-7)
Use: 6 Hex Bolt (1/4 x 3/4) (C03-0250-030)
6 Lock Washer (1/4 **Stainless**) (C02-0250-012)
6 Whiz Flange Nut (1/4) (C01-0250-030)

2 62851-41.....Sprocket 21-Tooth, (5/8 Bore)
Use: 2 Cotter Pin (3/16 x 1-1/4) (C20-0187-030)

- 1..... 62167-P8.....Blower Assembly, 8 GPM Hydraulic Motor**
- 1 B56-08636-1.....Front Housing, Blower (Plastic)
 Use: 14 Hex Bolt (1/4 x 3/4) (C03-0250-30)
 28 SAE Washer (1/4) (C02-0250-020)
 14 Lock Nut, Nylon (1/4) (C01-0250-040)
- 1 B56-08636-2.....Back Housing, Blower (Plastic)
- 1 5608636-4.....Back-Up Plate
 Use: 4 Carriage Bolt (3/8 x 1-1/4) (C04-0375-051)
 4 Lock Nut, Nylon (3/8) (C01-0375-041)
- 1 62167-2.....Mount, Blower (Plastic w/Coupler)
 Use: 1 Decal, Warning Rotating Parts (N02-0055-010)
 1 Decal, Important Hydraulic Motor (N02-0062-043)
 1 Decal, Black on Yellow (N02-0062-050)
- 1 L01-0034-004.....Fan, Impeller
 Use: 1 Bushing (1-inch JA Bore) (L01-0033-002)
- 1 5408320-25.....Key, Fan Shaft (1/4 x 1)
- 1 62167-3.....Shaft (6 Inch Long)
- 1 28122-49.....Key, for Coupler (3/16 sq. x 1)
- 1 K18-M024-000.....Coupler (9/16 x 7/8)
- Replacement Parts(K18-M024-003 Black Plastic Coupler Sleeve) (5508230-5 1/8 x1 Key)
 (K18-M024-004 Coupler for 9/16 Shaft on Hyd Motor)
 (K18-M024-005 Coupler for 7/8 Shaft on End of Fan Shaft)
- 1 K01-0045-003Hydraulic Motor, 8-GPM Casappa
 Use: 2 Carriage Bolt (3/8 x 1-1/4) (C04-0375-051)
 2 Washer, Motor Side, Stainless (62164-2)
 2 Lock Nut, Nylon (3/8) (C01-0375-041)
- 2 D05-1000-030Bearing & Locking Collar (For 1-inch Shaft)
- 4 D10-1000-011Flangette, Round
 Use: 6 Carriage Bolt (5/16 x 1) (C04-0312-040)
 6 Lock Washer (5/16) (C02-0312-010)
 6 Hex Nut (5/16) (C01-0312-010)
- 1 5608231-3.....Screen, Blower
 Use: 3 Pan Head Sheet Screw (#10 x 3/4) (C07-0187-090)
- 1 5508336-7.....Guard, Blower Shaft
 Use: 2 Thumb Screw (5/16 x 3/4) (C09-0312-100)
- 2 K02-0500-120Hydraulic Hose, 1/2 x 120"
- 2 K02-0500-014Hydraulic Hose, 1/2 x 14" w/ O-Ring Fitting On One End
- 1 K02-0375-024Hydraulic Hose, 3/8 x 24" (Case Drain)
- 1 L04-0005-000.....Cable Tie (5/16 x 15-1/4)
- 1 L04-0000-000.....Tag, Important, Caution
- 1 62113.....Hydraulic By-Pass Block Assembly w/Check Valve**
- 1 K05-CV10-200.....Check Valve
- 1 6296-1.....Hydraulic By-Pass Block

The Following Parts Are Located Inside Hopper:

- 1..... 0197102-1..... Manual Holder Bracket
- 2..... L04-0005-000..... Cable Tie (5/16 x 15-1/4)
- 1..... M10-0005-004..... Manual Holder

1..... 6216-D..... Air Pressure Gauge Carton Containing: (inside Hopper)

- 1..... K17-P734-004..... Air Pressure Gauge 4 Inch
- 2..... K04-0250-375..... Adaptor, Plastic, 1/4 MPT x 3/8 HB
- 1..... 62851-46..... Mounting Bracket, Air Pressure Gauge
- 1..... 62851-47..... Clamp Bracket
- 4.5 Ft... M06-0375-000..... Tubing 3/8 I.D. x 1/8 Wall (One Piece 54 Inches long)
- 1..... C03-0312-041..... Hex Bolt (5/16 x 1)
- 1..... C01-0312-030..... Whiz Flange Nut (5/16)

1..... 62242-A..... Parts Carton Containing The Following:

1..... 629066-C..... Enclosed Console Assembly, 3 Lights, 3 Switch

- 1..... 5508338-23..... Enclosed Console, Front
- 1..... 5508338-24..... Enclosed Console, Back
 - Use: 4 Pan Head Sheet Screw (#10 x 5/16) (C07-0187-040)
 - 2 Hex Bolt (1/4 x 3/4) (C03-0250-30) **(in Place)**
 - 2 Whiz Flange Nut (1/4) (C01-0250-030) **(in Place)**
- 1..... C07-0164-051..... Phillips Head Screw (#8-32 x 3/8)
- 1..... C01-0164-040..... Kep Nut (#8/32)
- 3..... M05-2858-000..... Rubber Grommet (3/8 I.D.)
- 1..... L05-0008-000..... Amber Light
- 2..... L05-0008-020..... Green Light
- 3..... L05-0001-050..... Switch, Toggle On/Off (#90-001)
- 1..... 629066-13..... Molded Connector, Female 8-inch w/Terminal
- 3..... L03-0005-000..... Wire Connector Blue (18-14ga)
- 1..... 5508338-10..... Molded Connector, Female 8-inch w/Terminal on White Wire
- 1..... 62853-47..... Power & Ground Wire, 10ga x 12 Ft
- 1..... 629066-12..... Wire Assembly, Electric Clutch, 36-inch
- 4..... L03-0003-070..... Molded Connector, 4 Contact, M & F, 144-inch Wire
- 24 Ft..... L05-0011-062..... Flex Guard Loom (2 – 12 Ft Pieces)
- 4..... 550829-4..... Blank Plate, Air Chamber
- 4..... 62852-20..... Blank Plate Metering Door
- 8..... 550828-3..... Bar Clamp
- 8..... 09072598-5..... Stud Bolt (5/8 x 13-1/2)
 - Use: 16 Lock Washer (5/8) (C02-0625-010) (In Hardware Bag)
 - 16 Hex Nuts (5/8) (C01-0625-010) (In Hardware Bag)

1..... 6216-H..... Hardware Bag Containing: (in Parts Box)

- 16..... C01-0625-010..... Hex Nut (5/8)
- 16..... C02-0625-010..... Lock Washer (5/8)

Cover Hinge Bolt Assembly

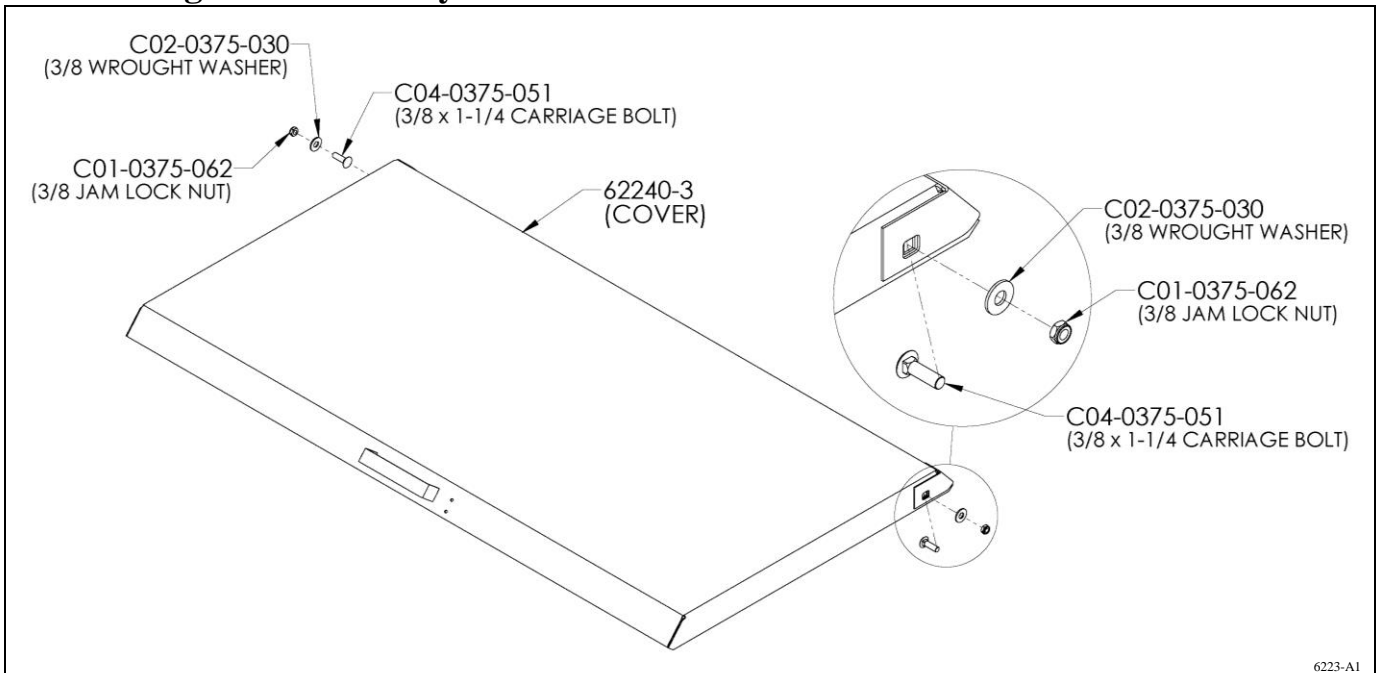

Roof Hinge Bolt Assembly

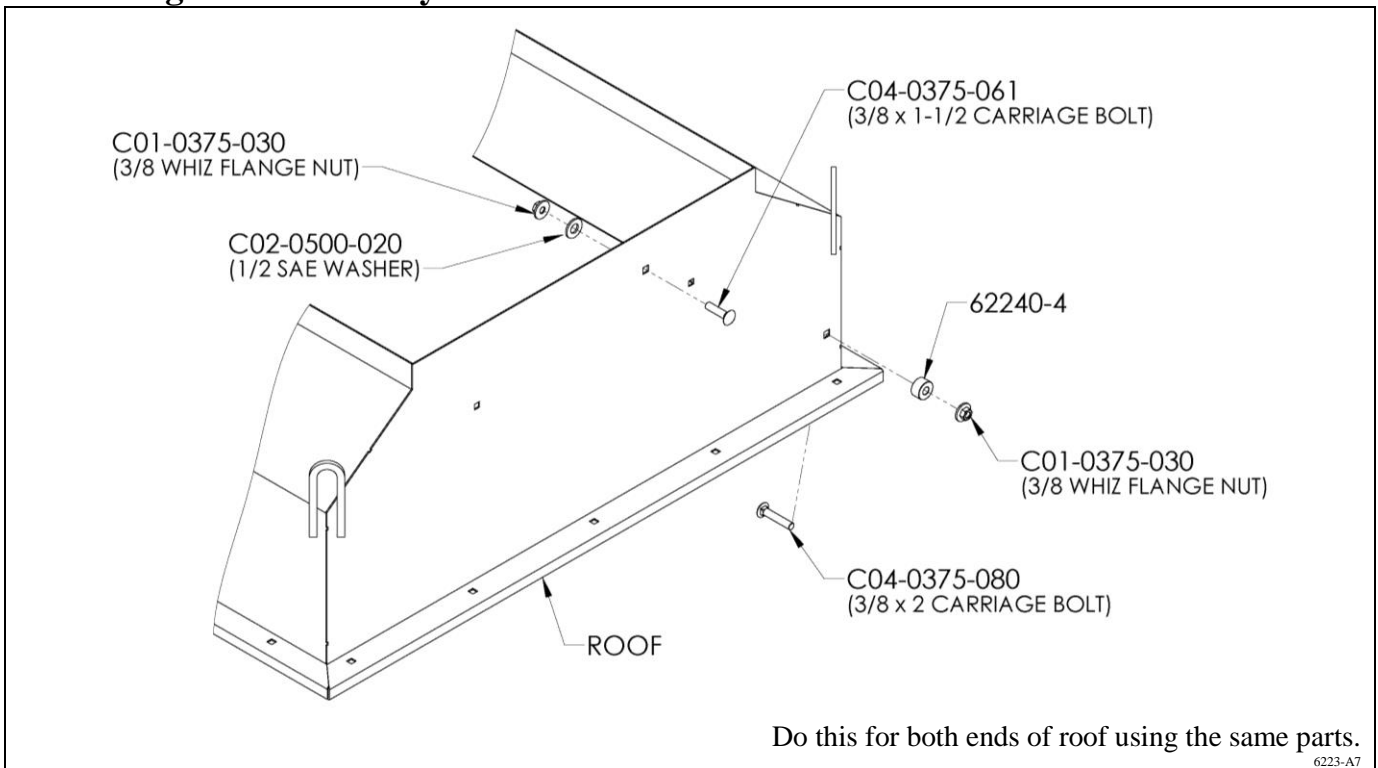

Roof Assembly

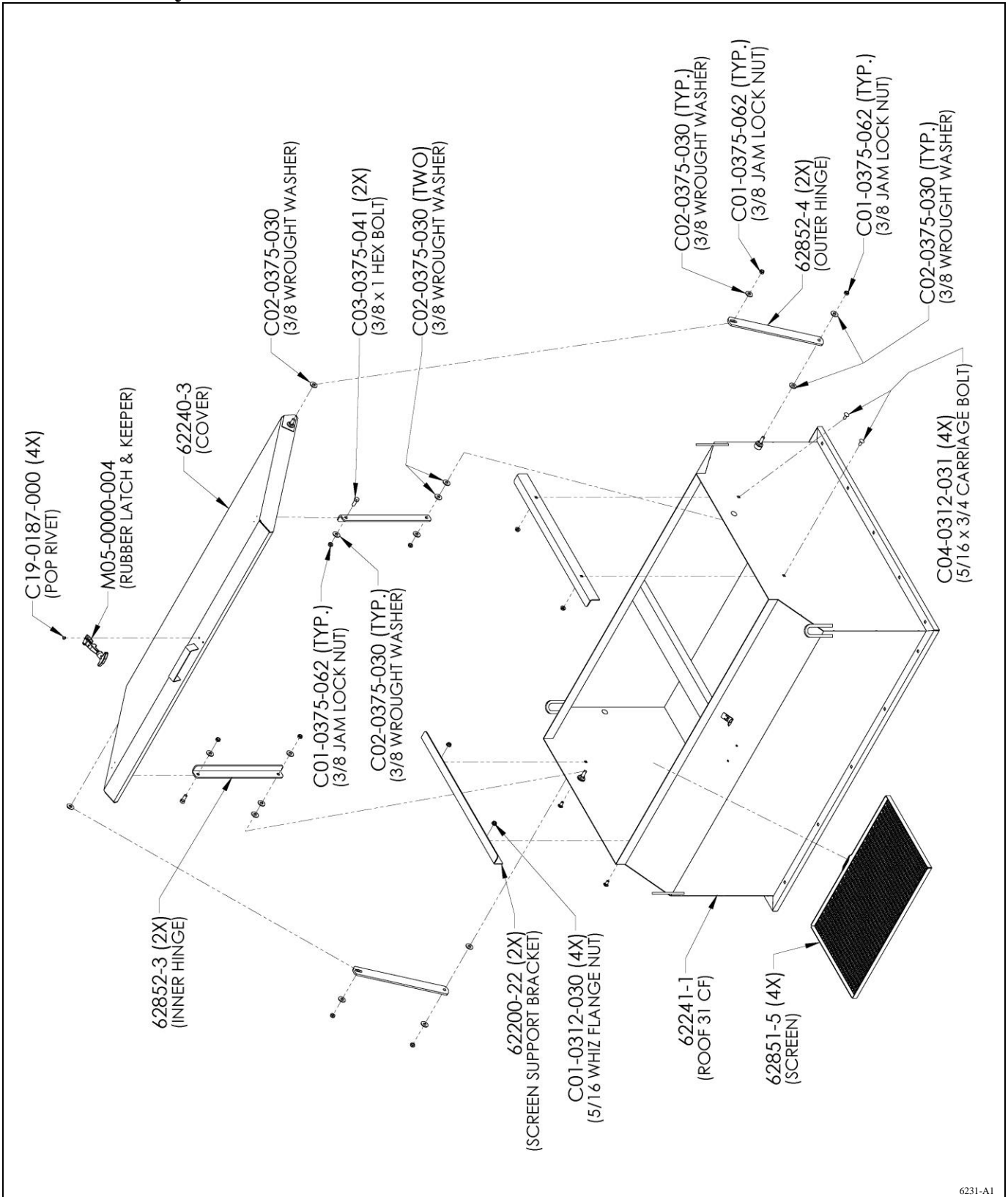

6231-A1

Sight Window Assembly

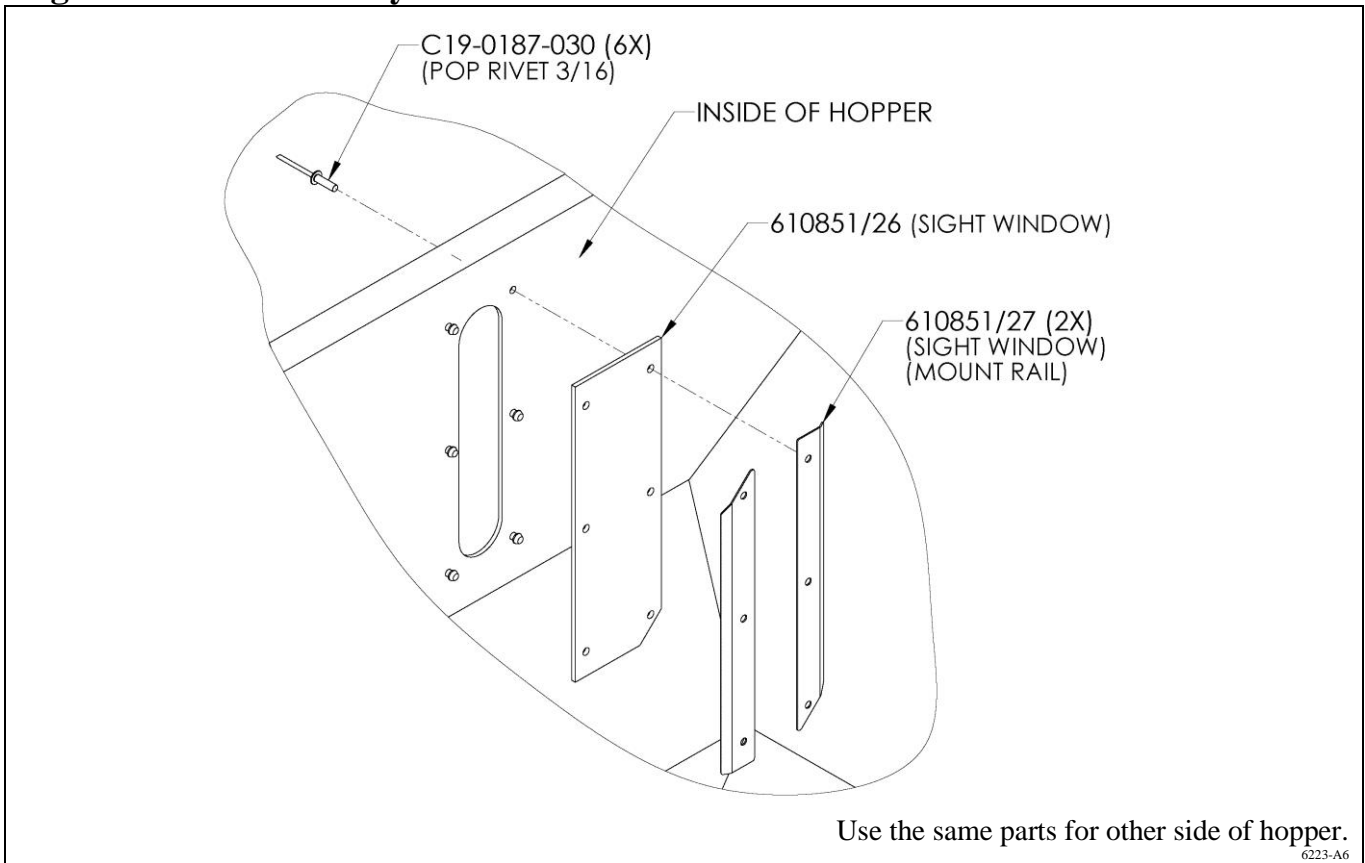

Roof to Hopper Assembly

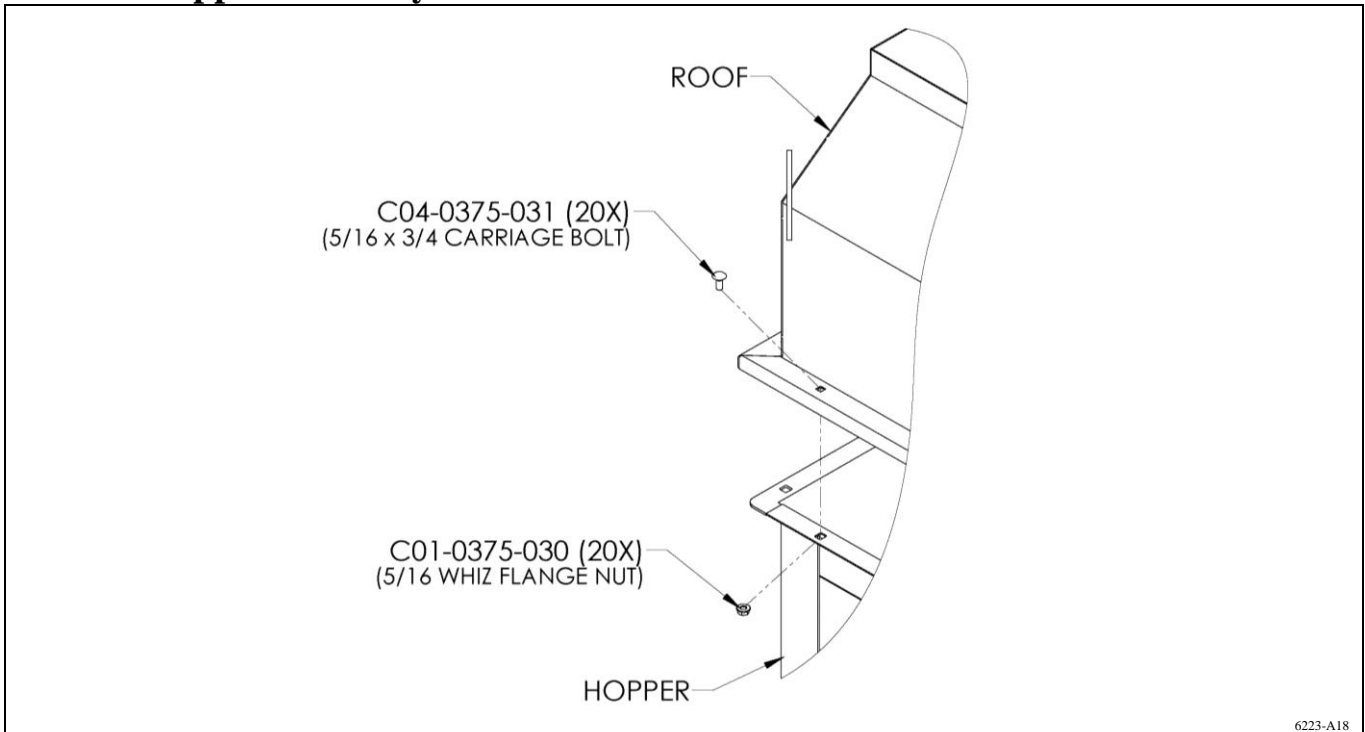

Hopper Assembly

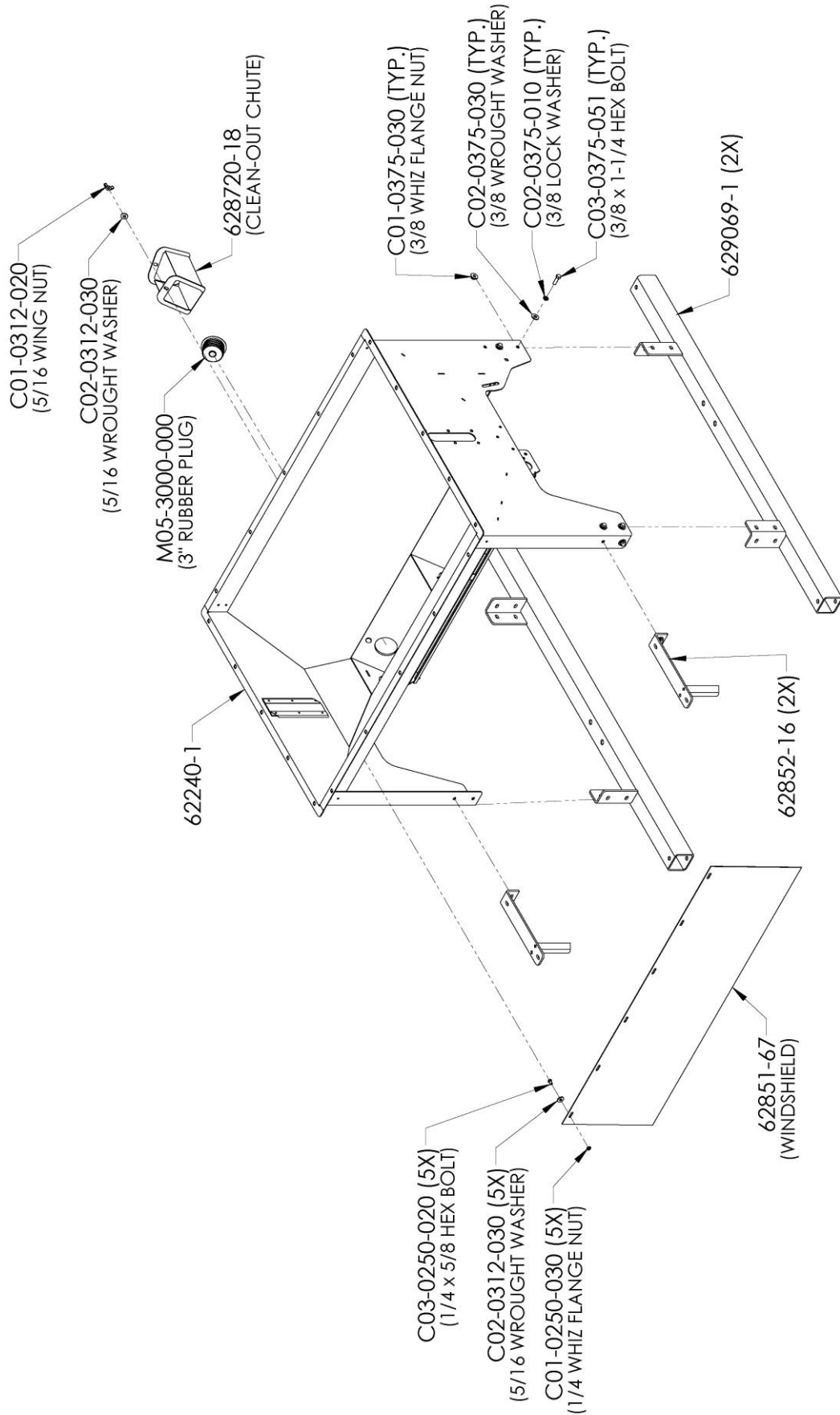

Hopper Assembly

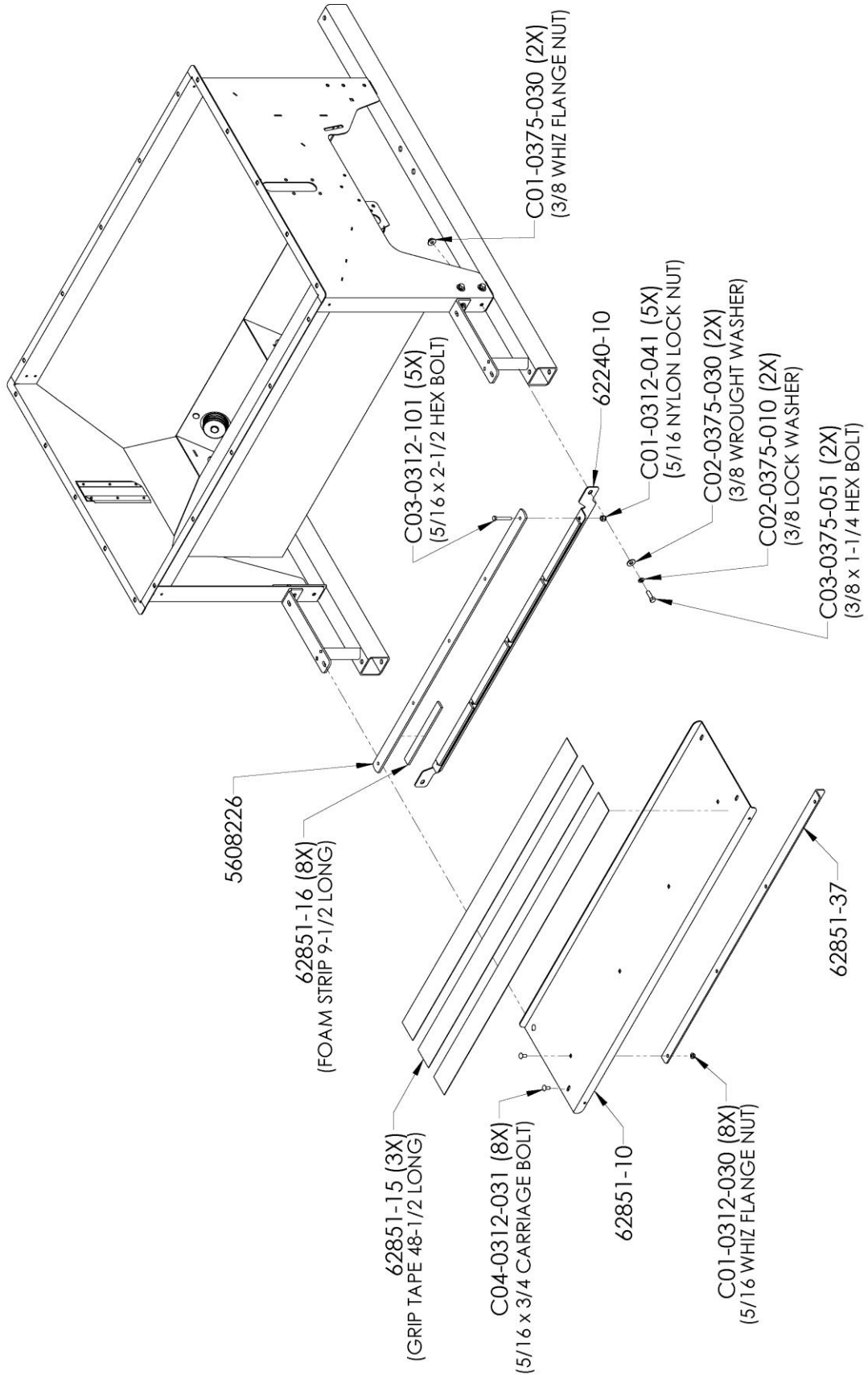

6223-A22

Electric Clutch Assembly (Drive Side)

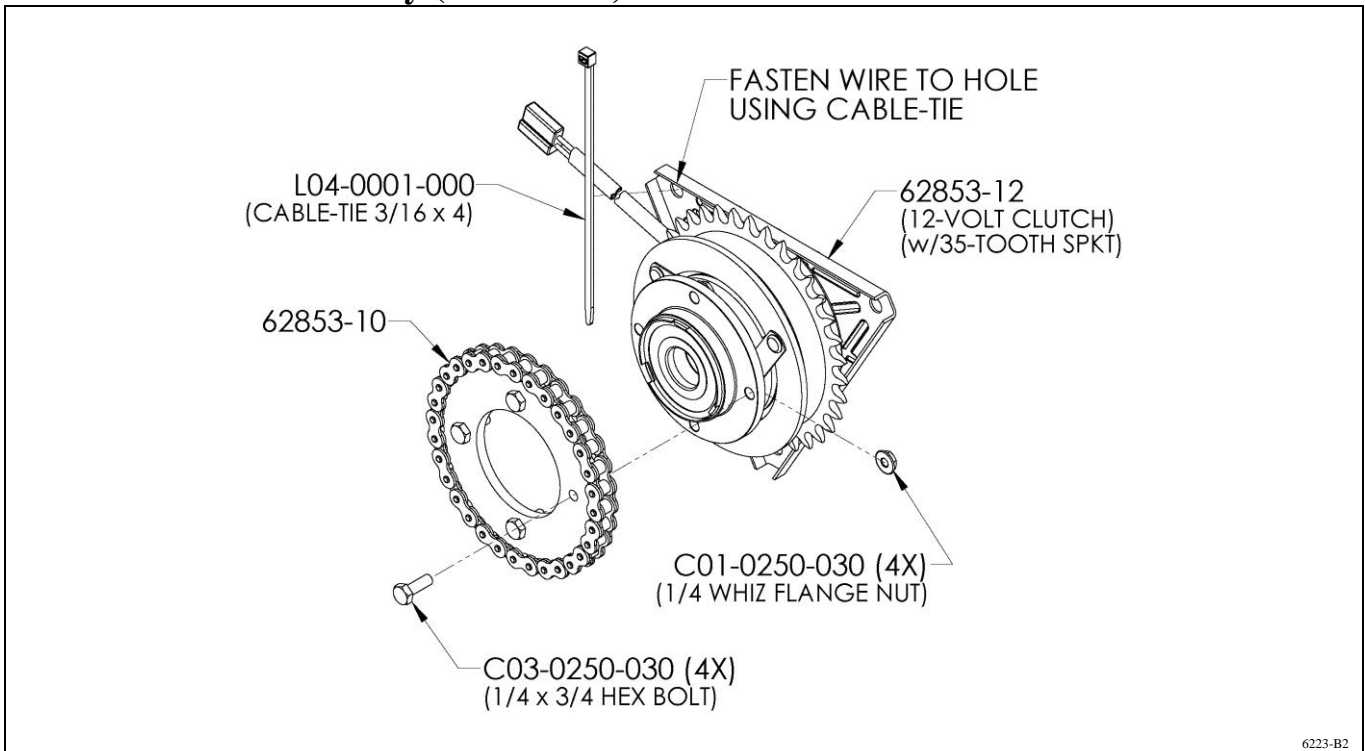

Electric Clutch Assembly

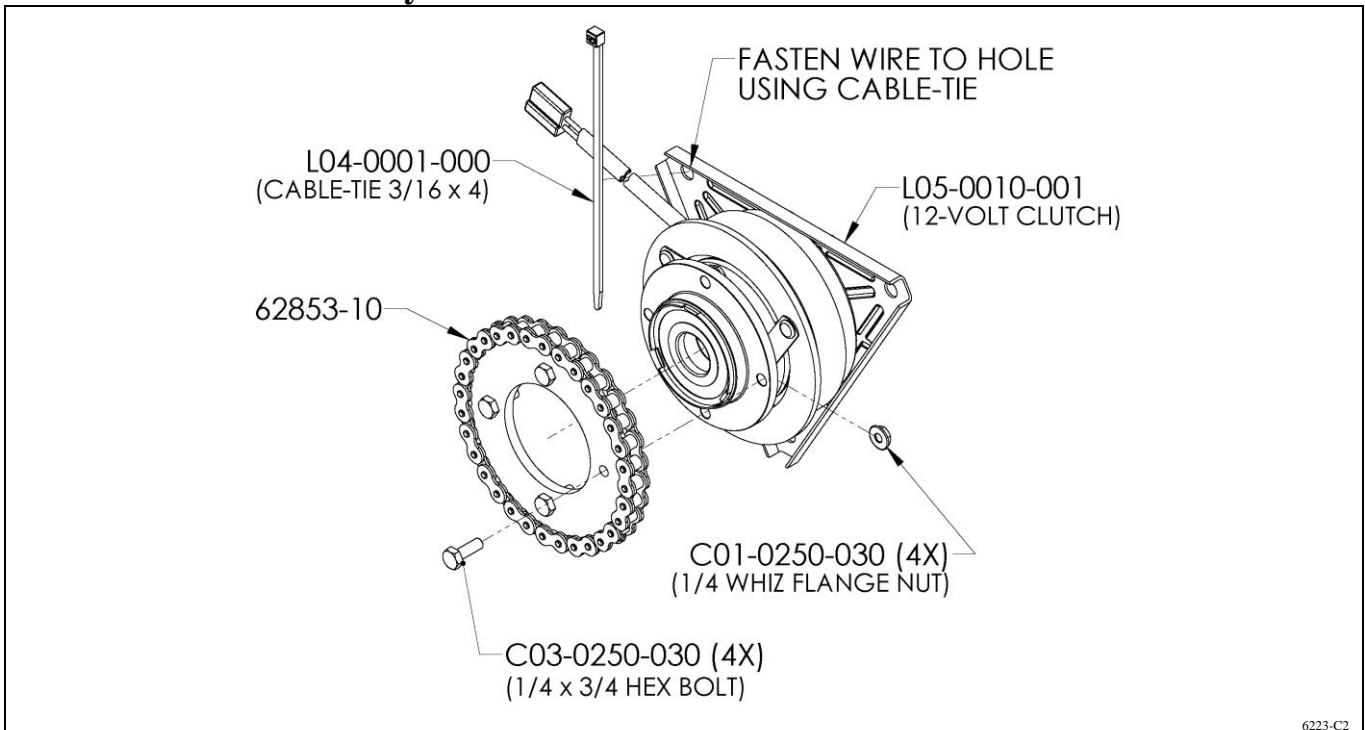

Clutch Bracket Assembly (Zero-Max Side)

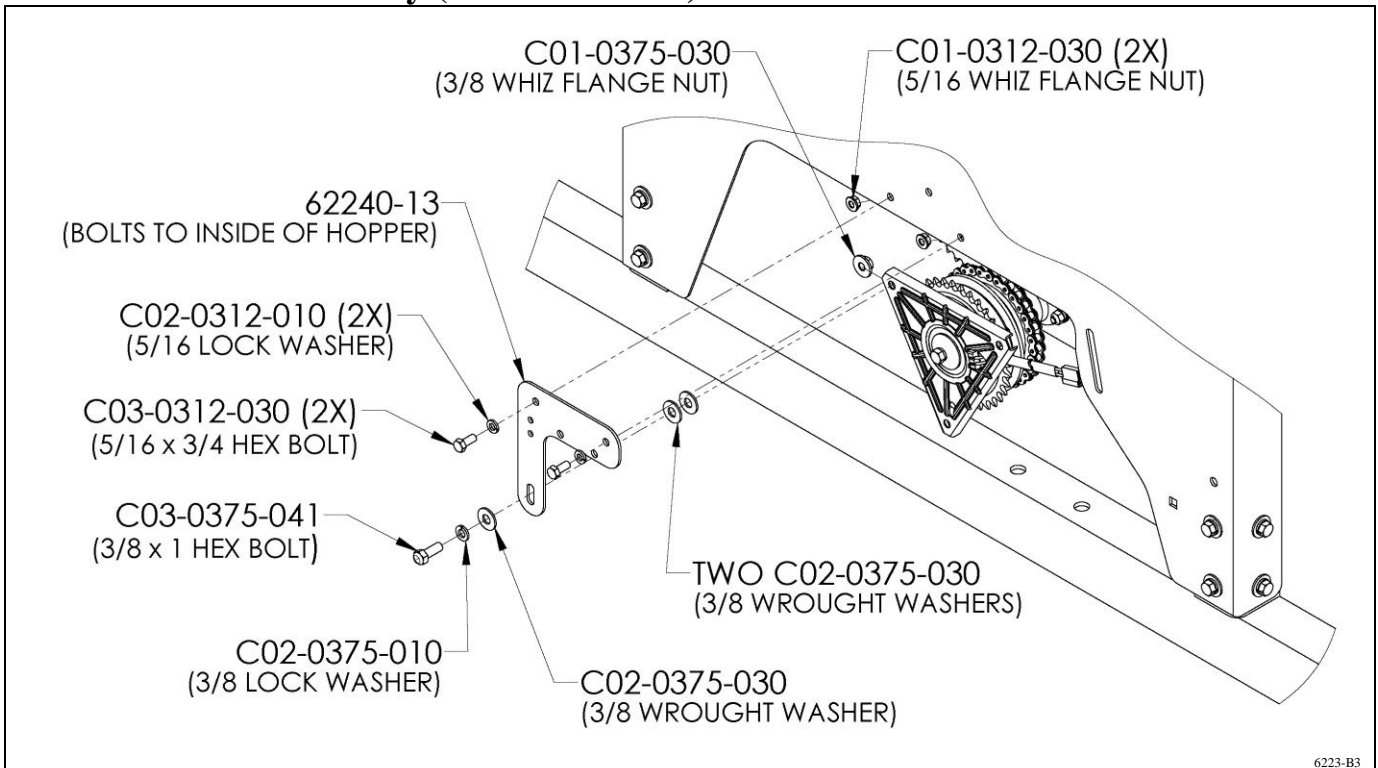

Clutch Bracket Assembly

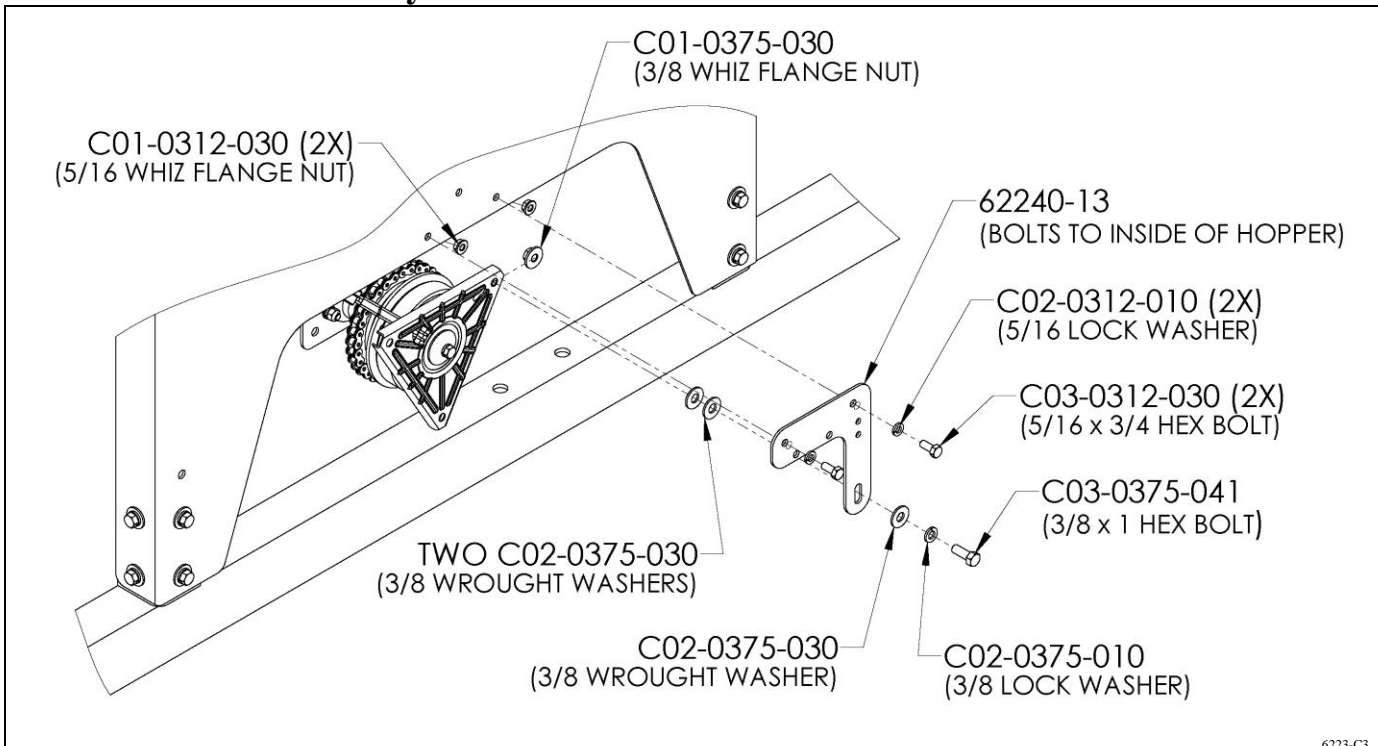

Zero-Max Assembly

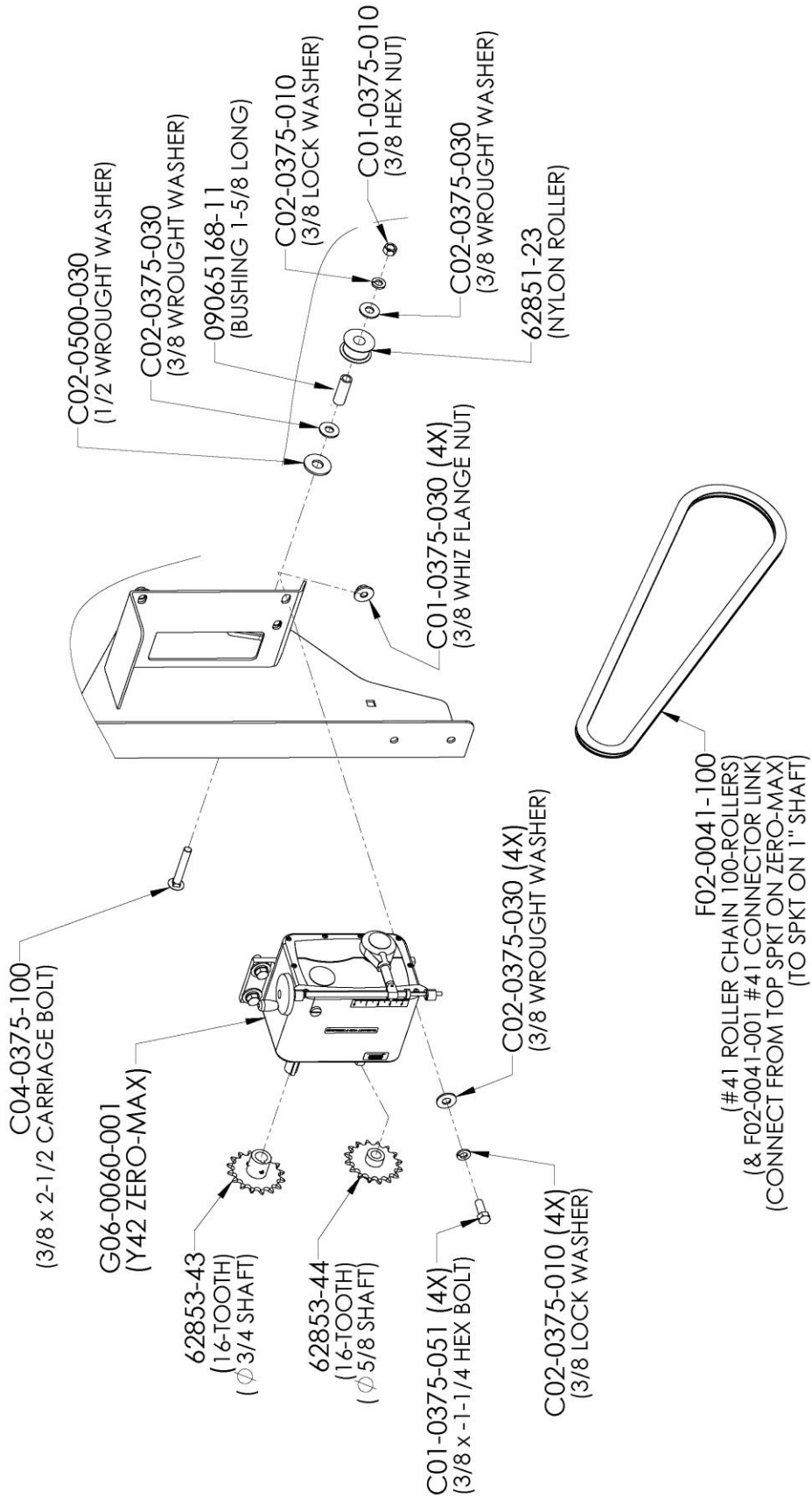

Jack Shaft Assembly (62240-J)

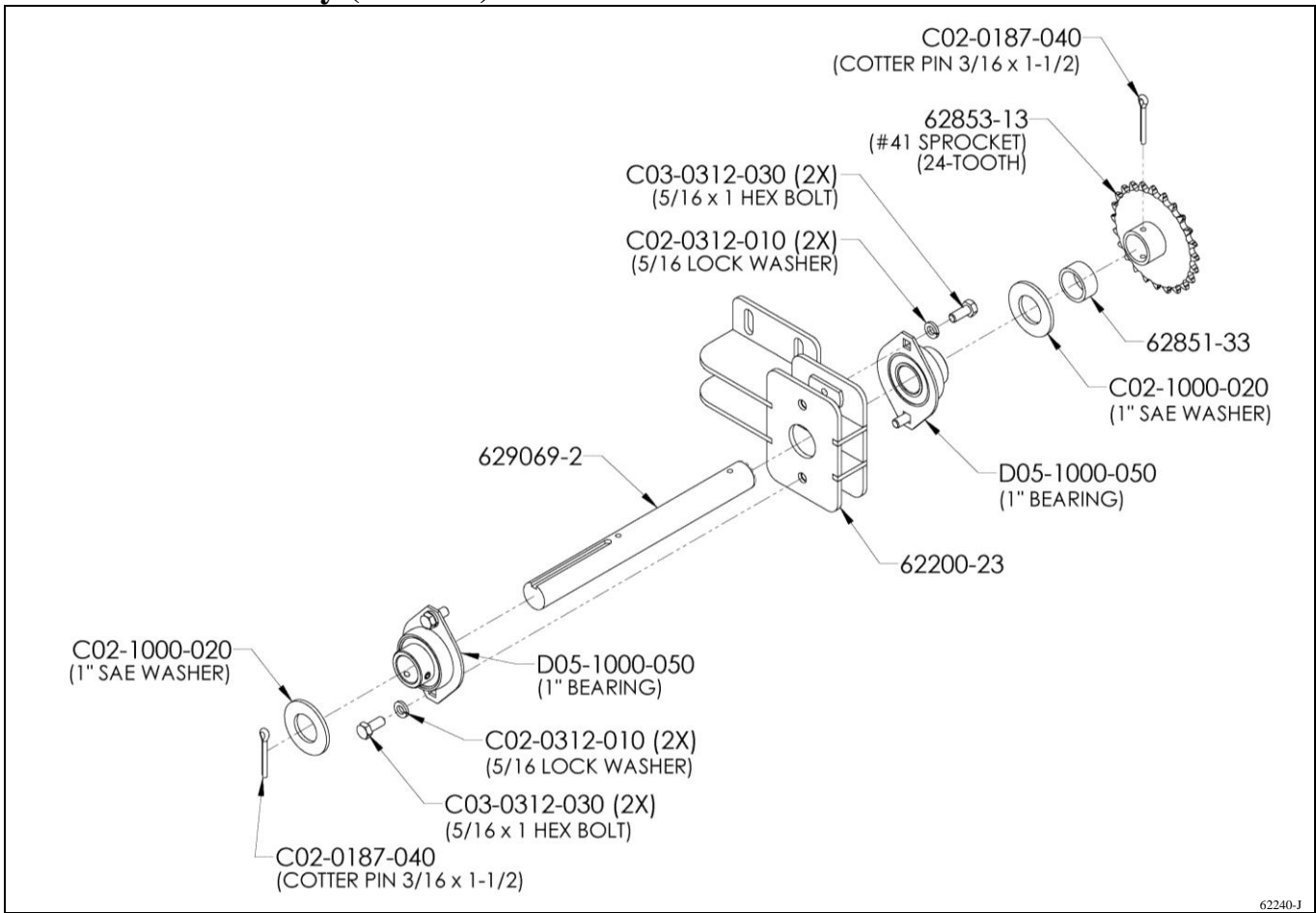

Jack Shaft to Hopper Assembly

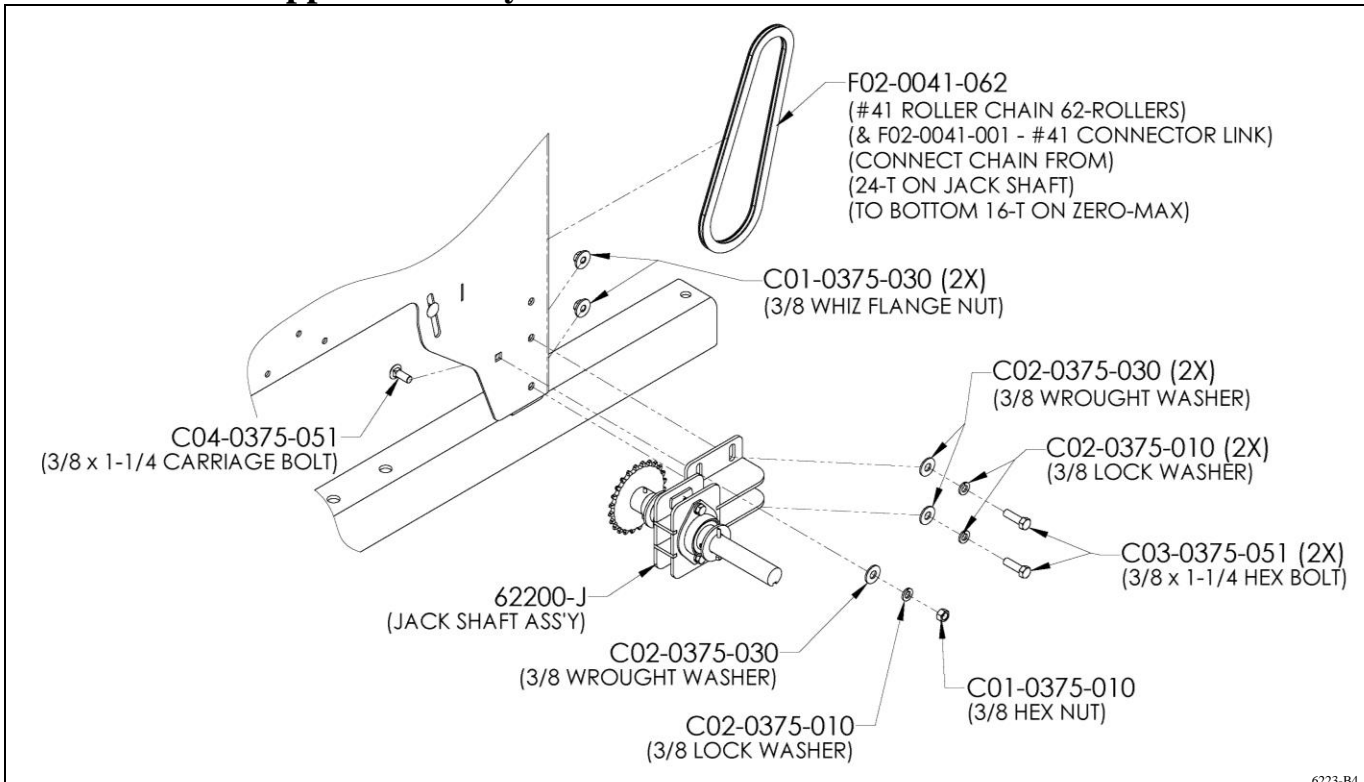

Metering Door Assembly (629066-A)

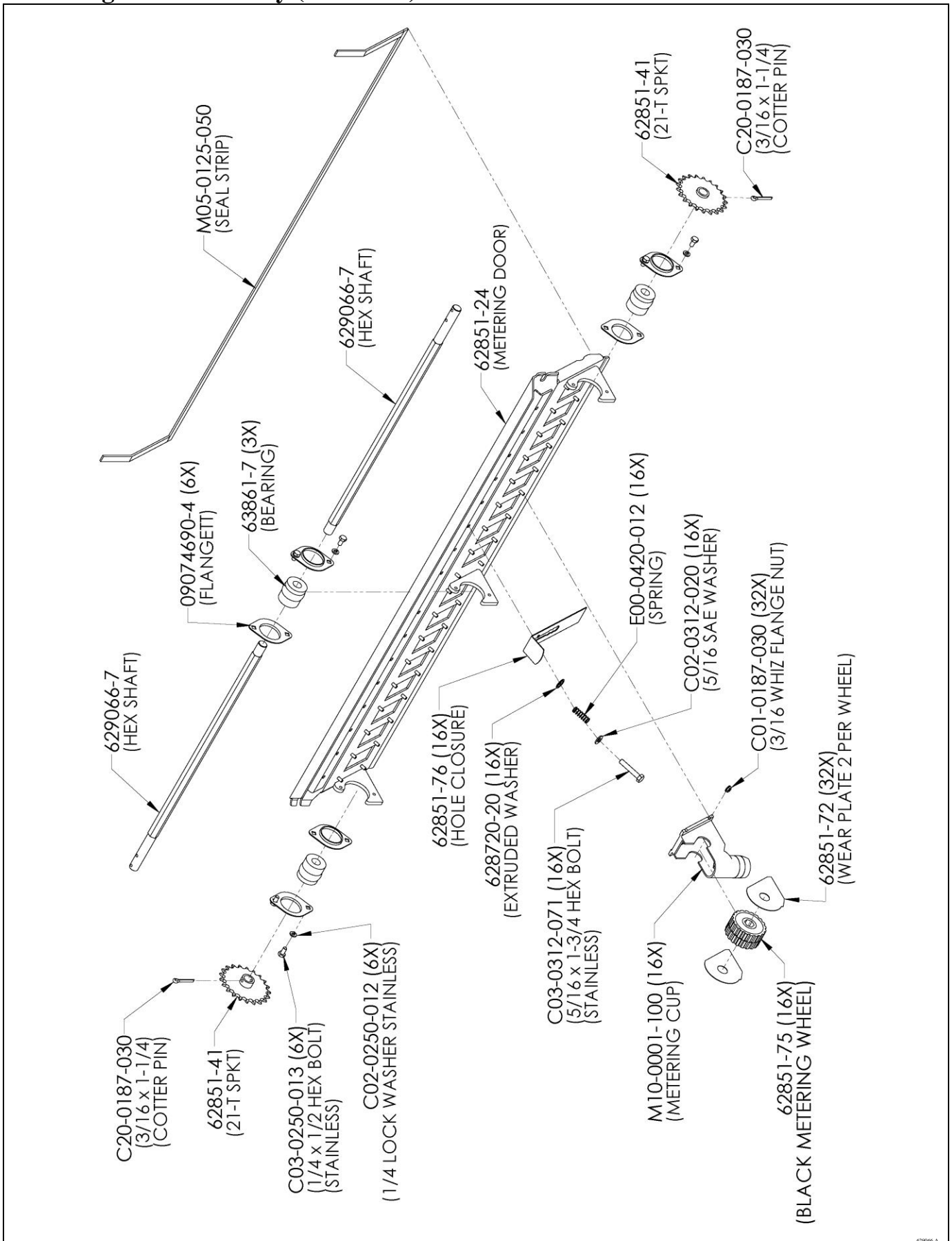

629066-A

Fastening Metering Door in Place (use one J-Bolt on each end of metering door)

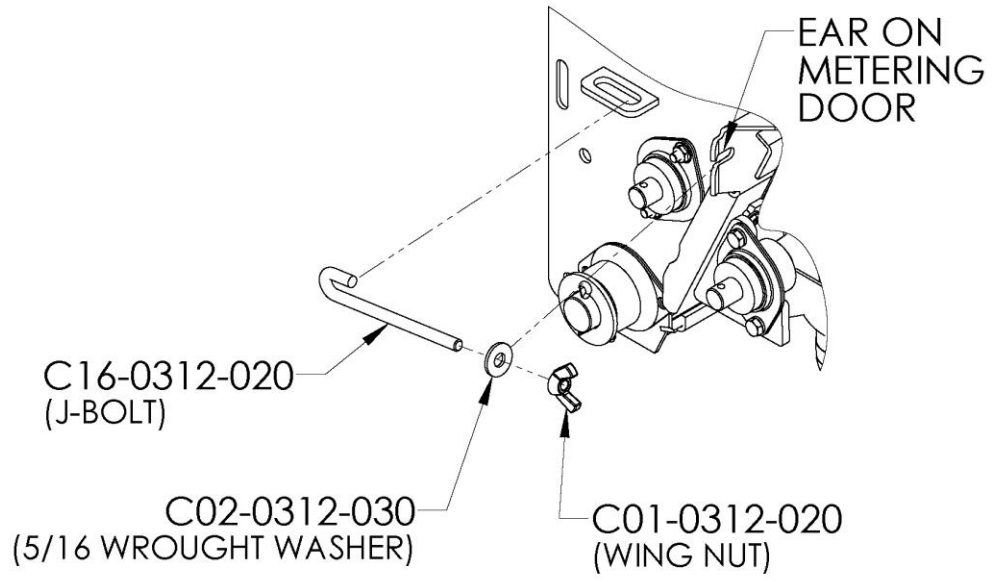

J-bolt shown in place.

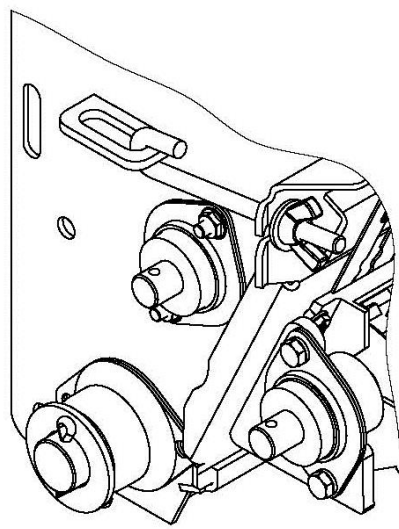

Air Chamber Assembly

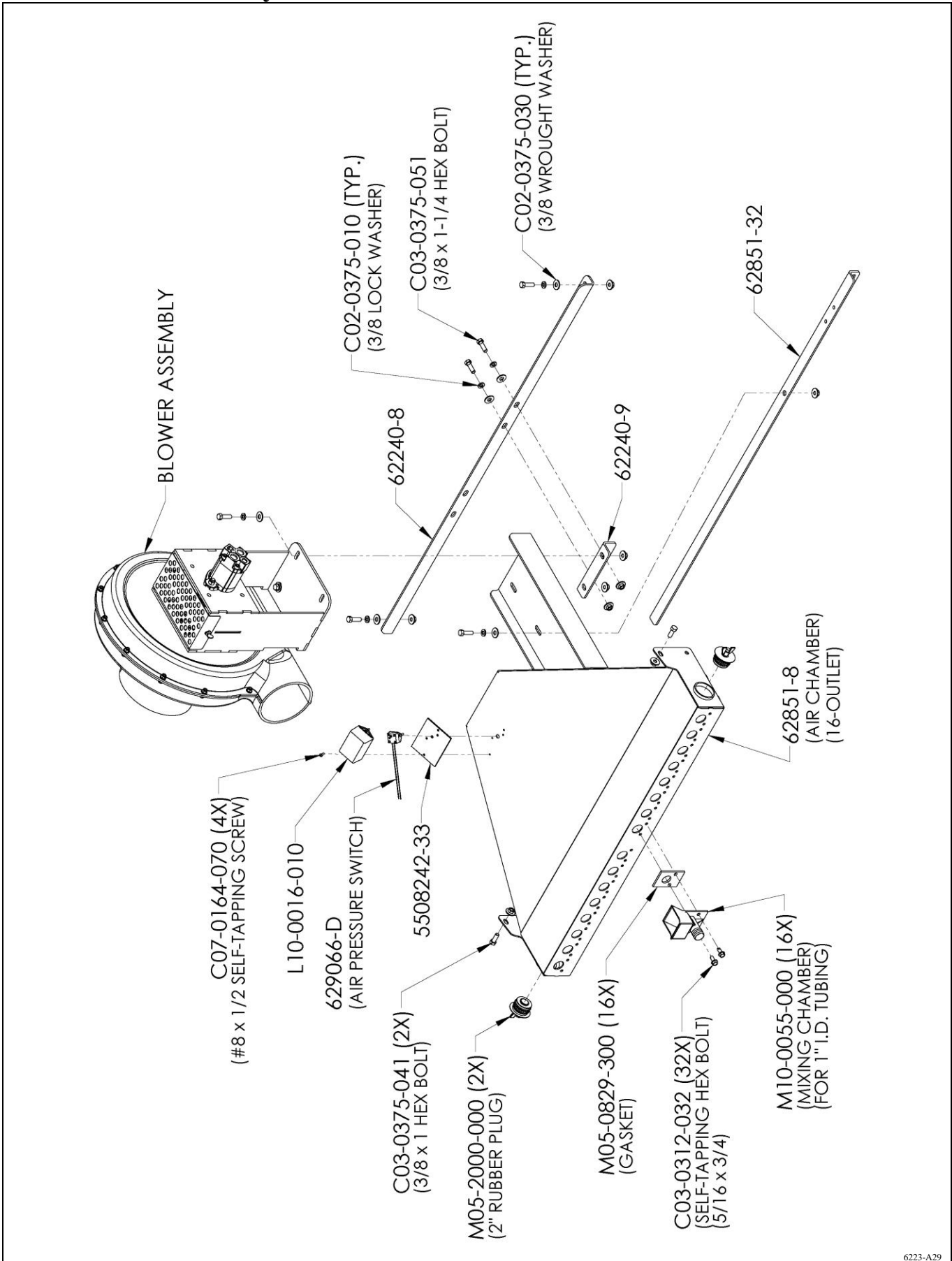

6223-A29

Hydraulic Blower Assembly (62167-P8)

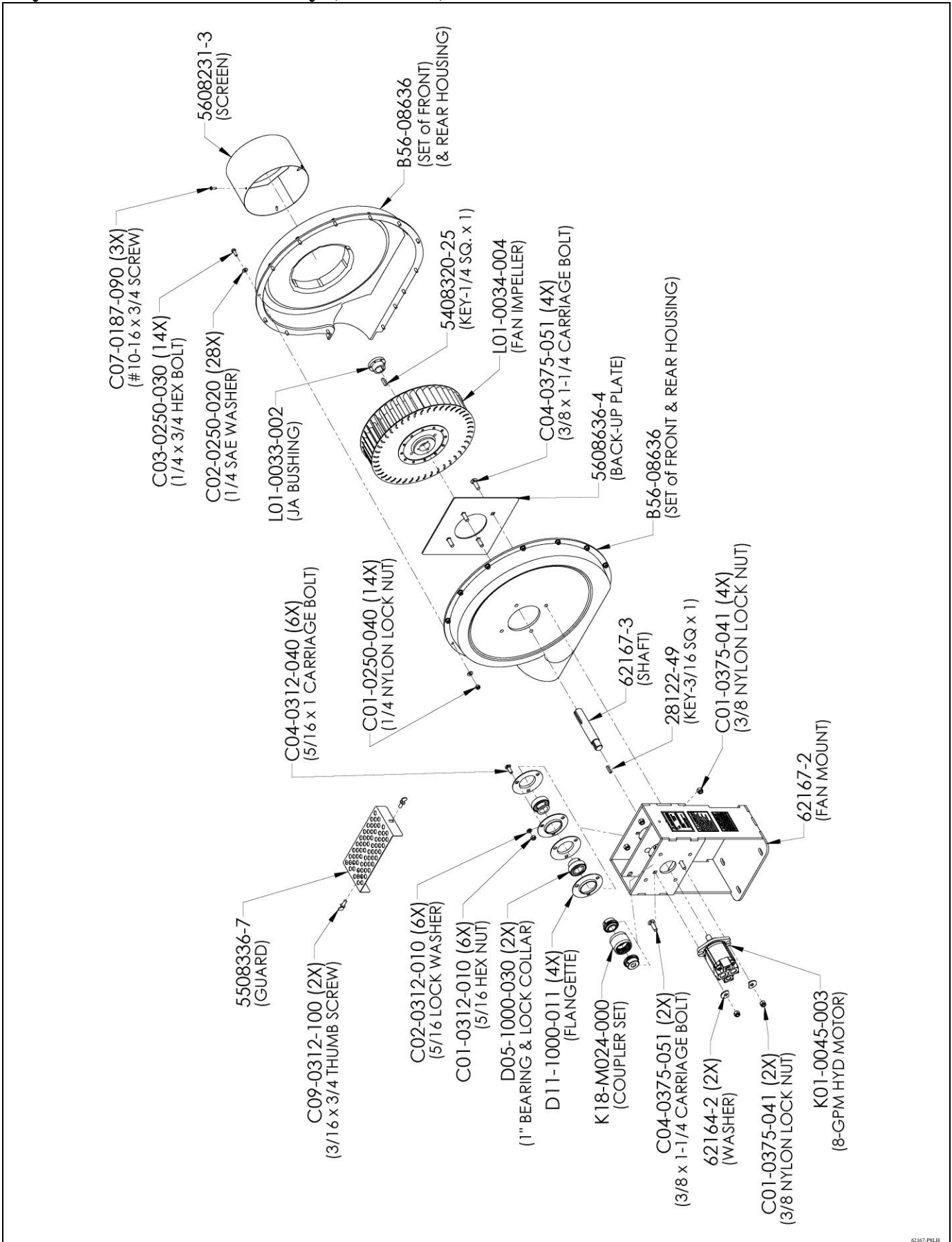

Hydraulic Hose Connections (For Gandy Plastic Housing Fan)

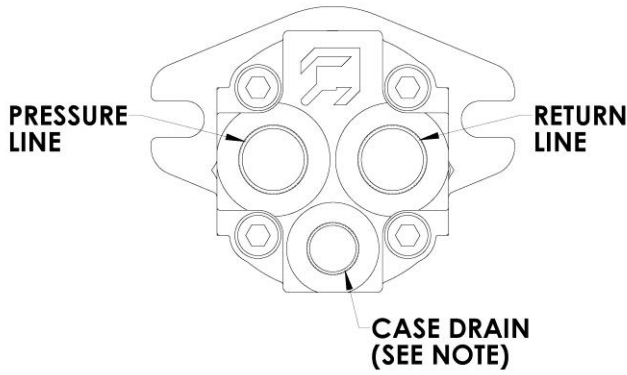

Note:
 Case drain hose needs to be run back to a non-flow port, sump or reservoir.
 This section of hose to be supplied by the customer.
 Use 1/2-inch hose for runs longer than 20-ft. Over 20-ft use 3/4" hose.

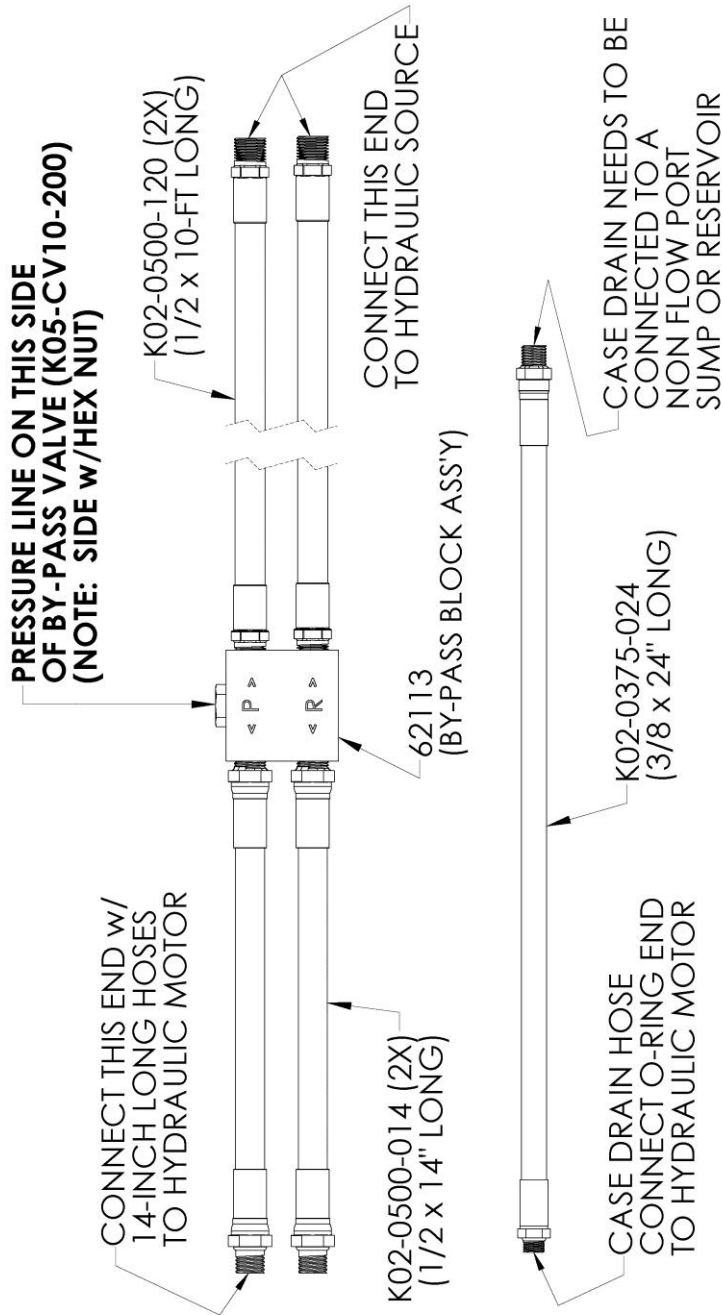

Shaft Sensor (Both Sides)

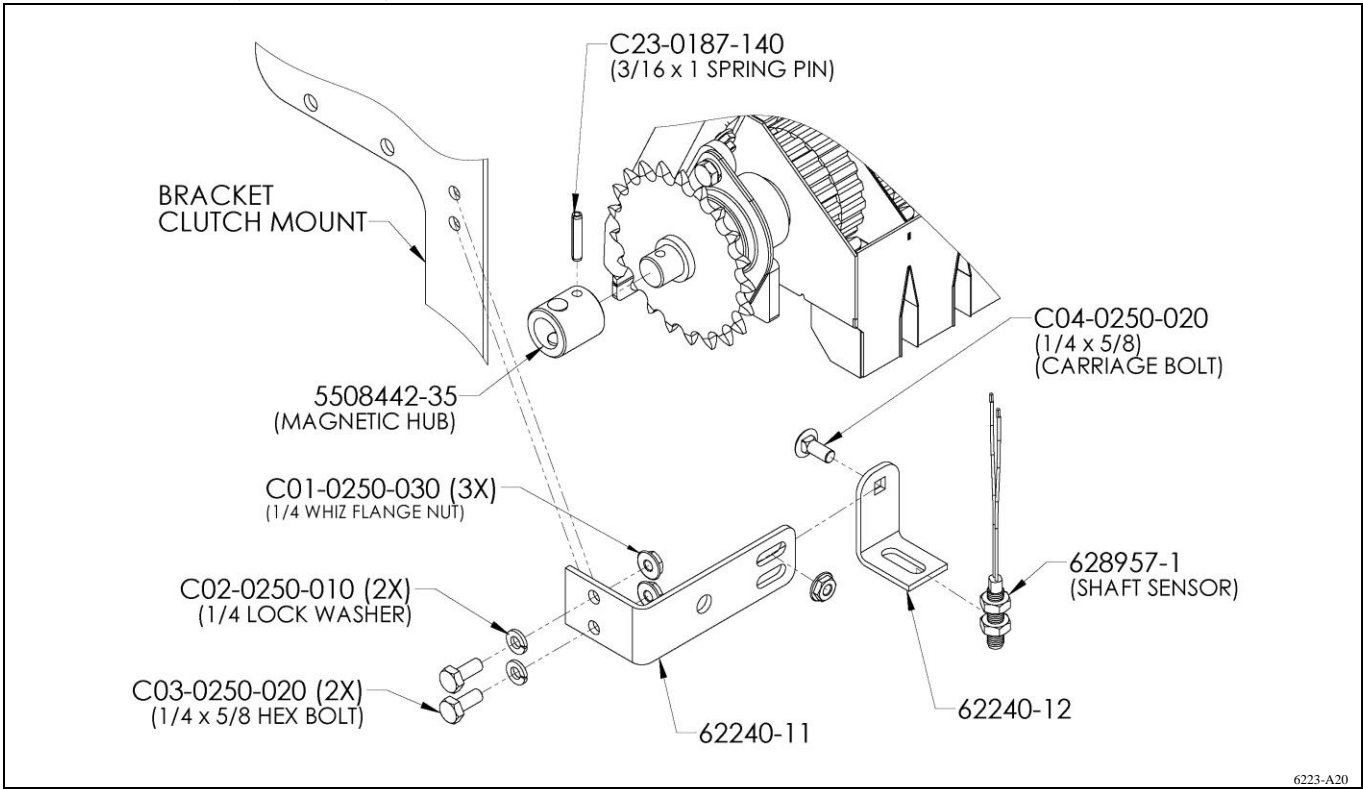

6223-A20

Zero-Max Decal Locations (on Zero-Max)

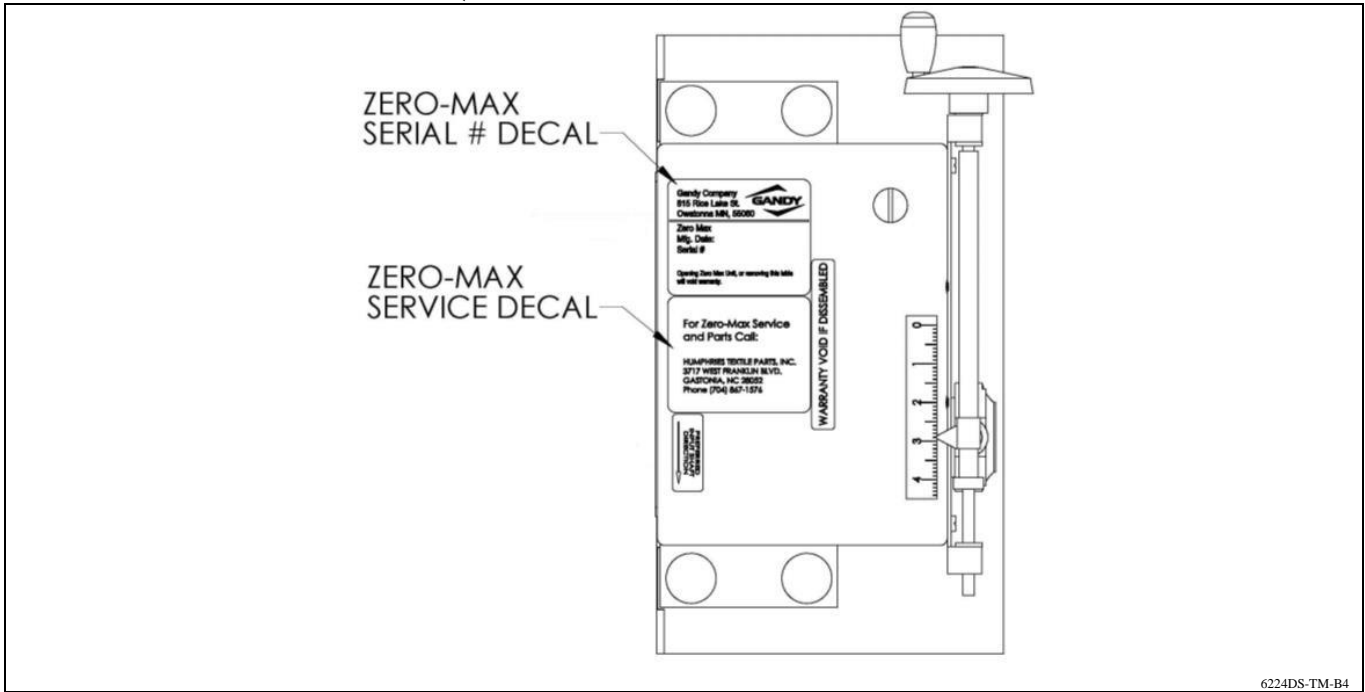

Decal Location (Zero-Max Side)

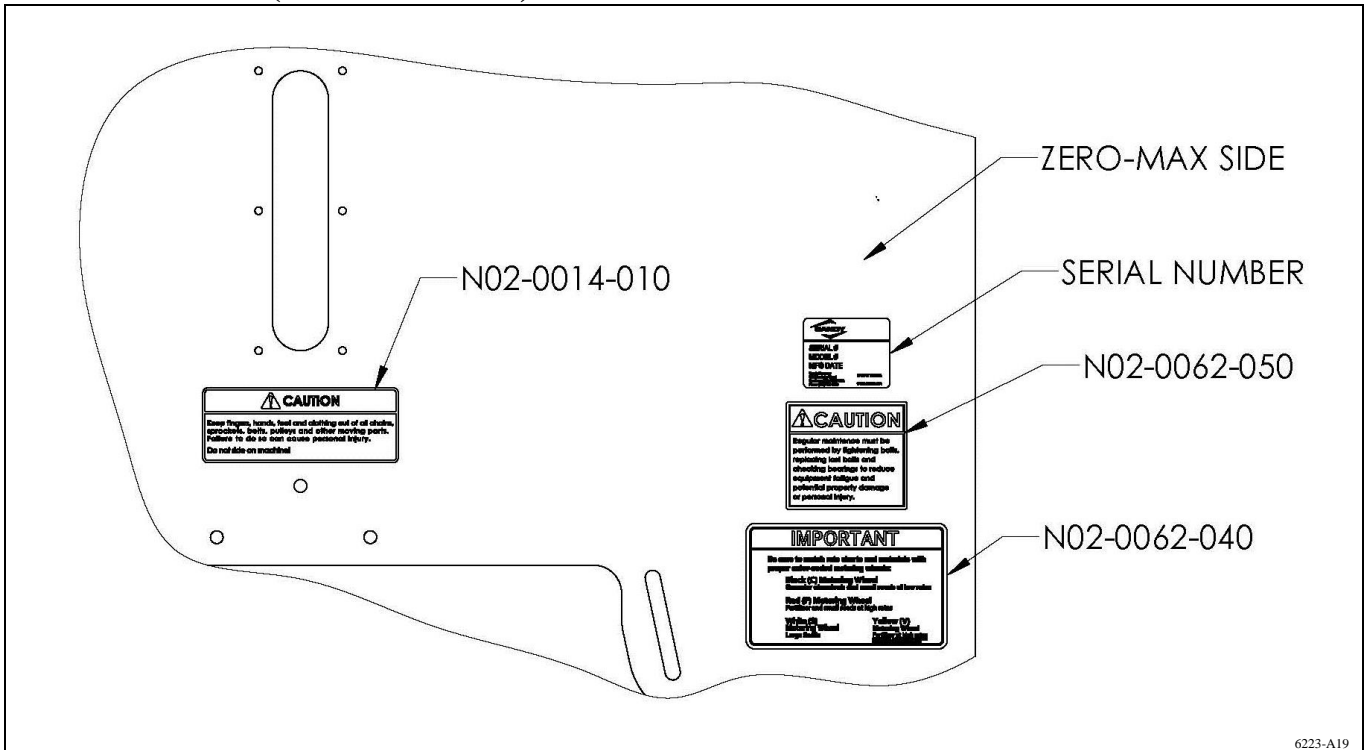

Decal Location (Opposite Side of Zero-Max)

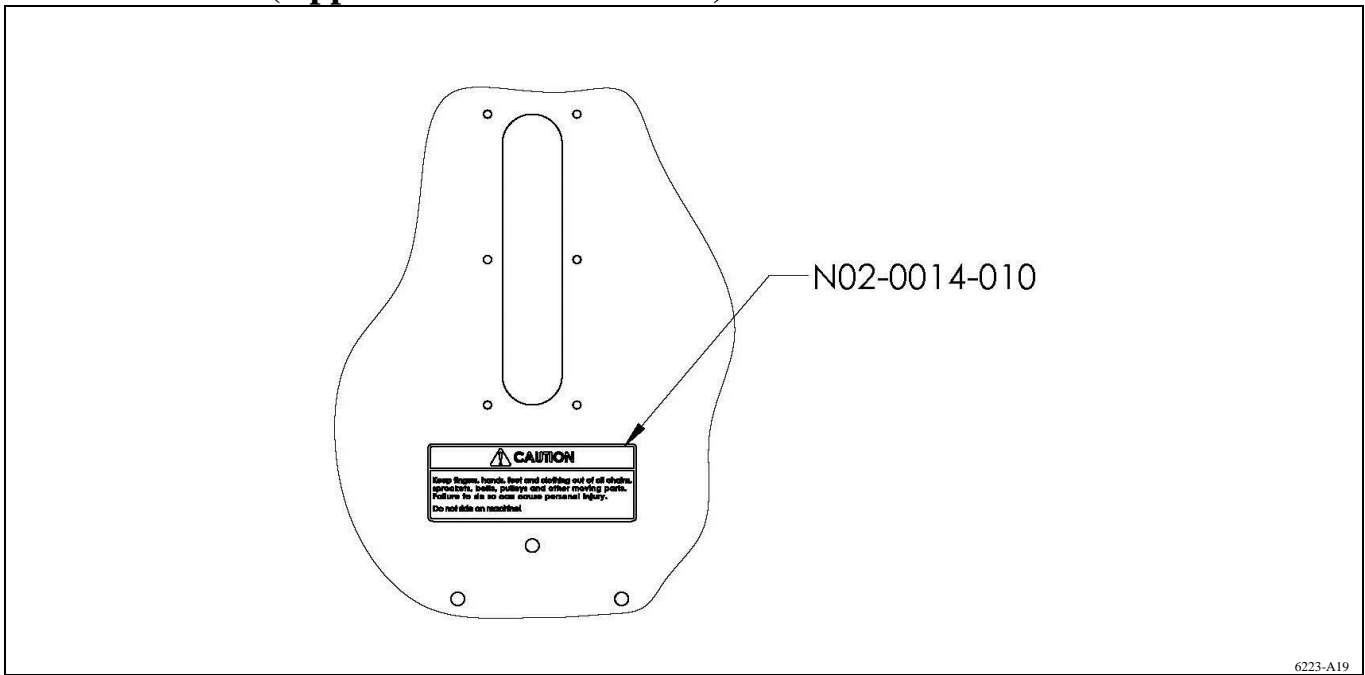

Clean-Out Decal Location

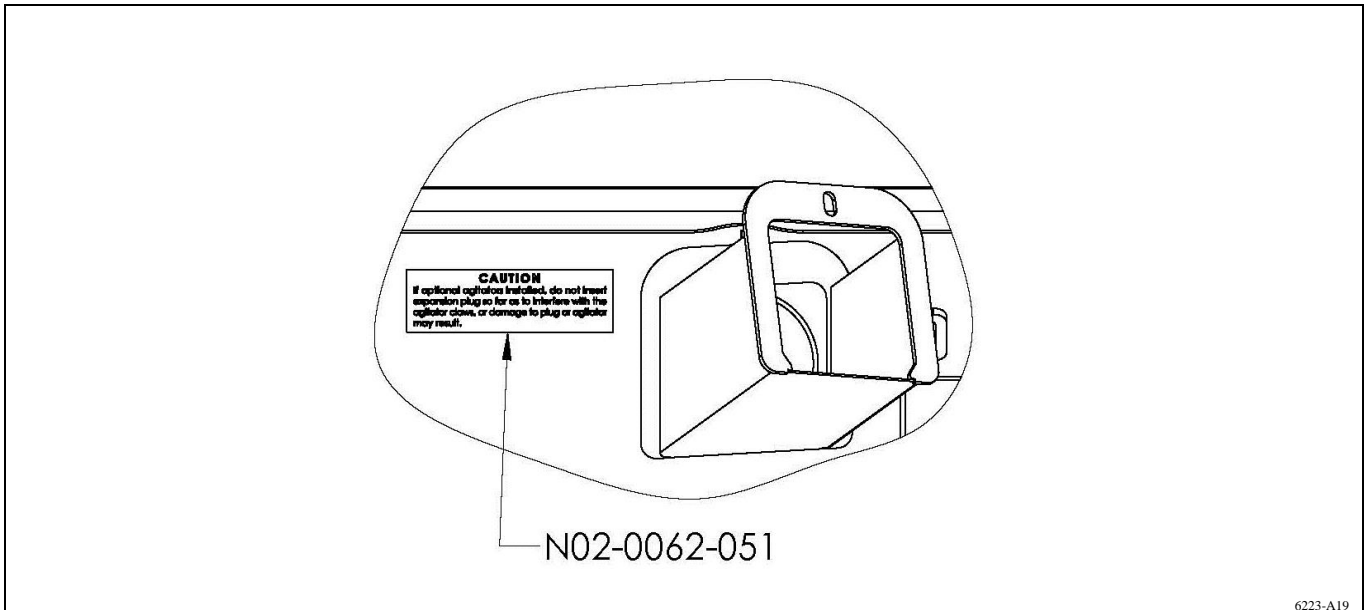

Front & Rear & End Decals

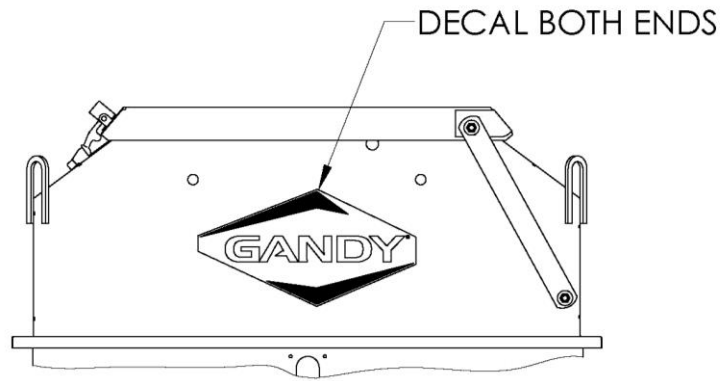
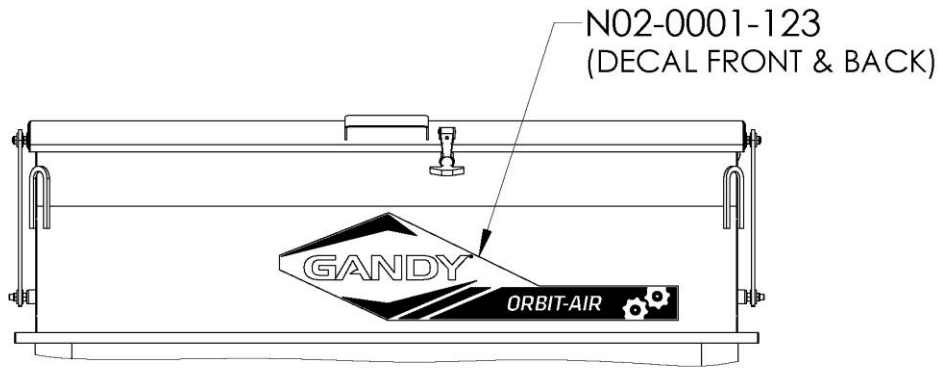

6223-A19

Console Schematic
(Back View of Console)

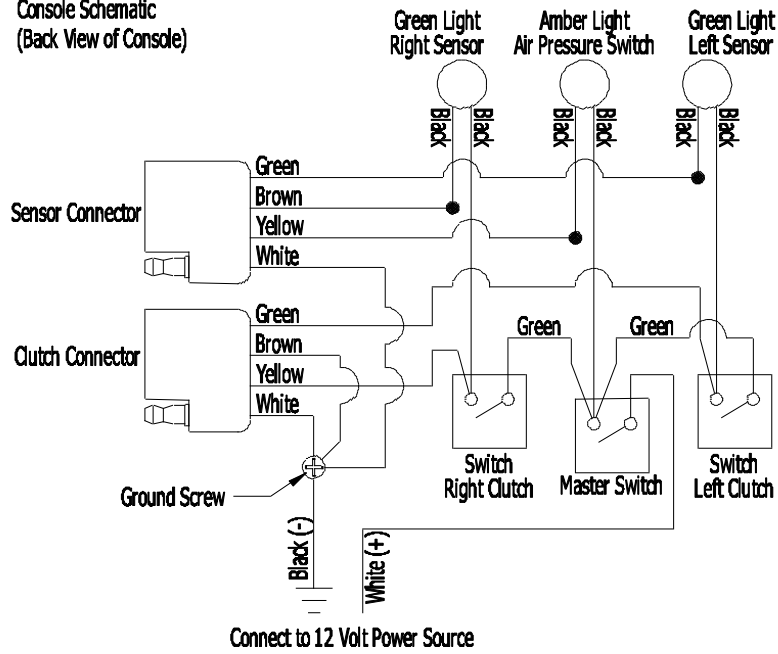

Clutch Wire Assembly Schematic
& Connecting to Clutches

Speed Control Side

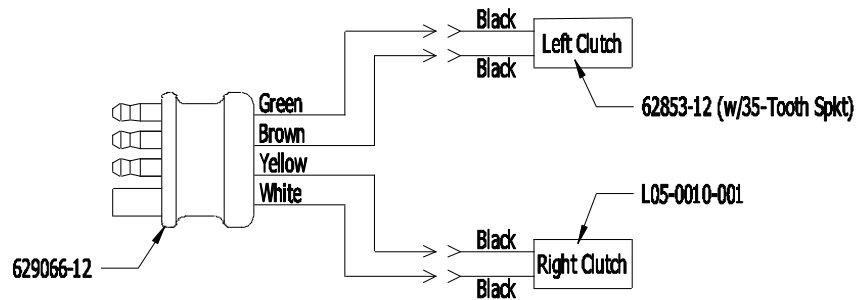

Air Pressure Switch (629066-D) Schematic
& Connecting to Shaft Sensors

Speed Control Side

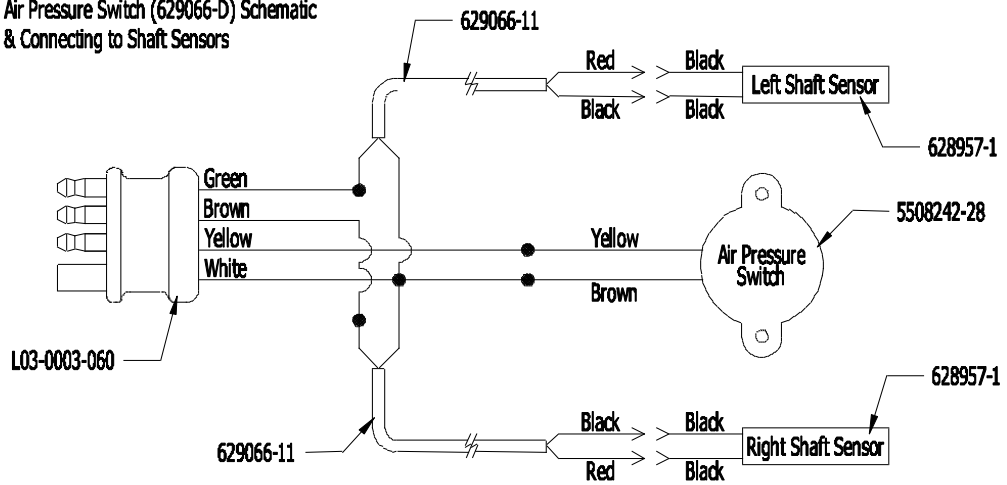

Wiring Connections:

Mount Console in convenient location in tractor cab and connect wires as shown.

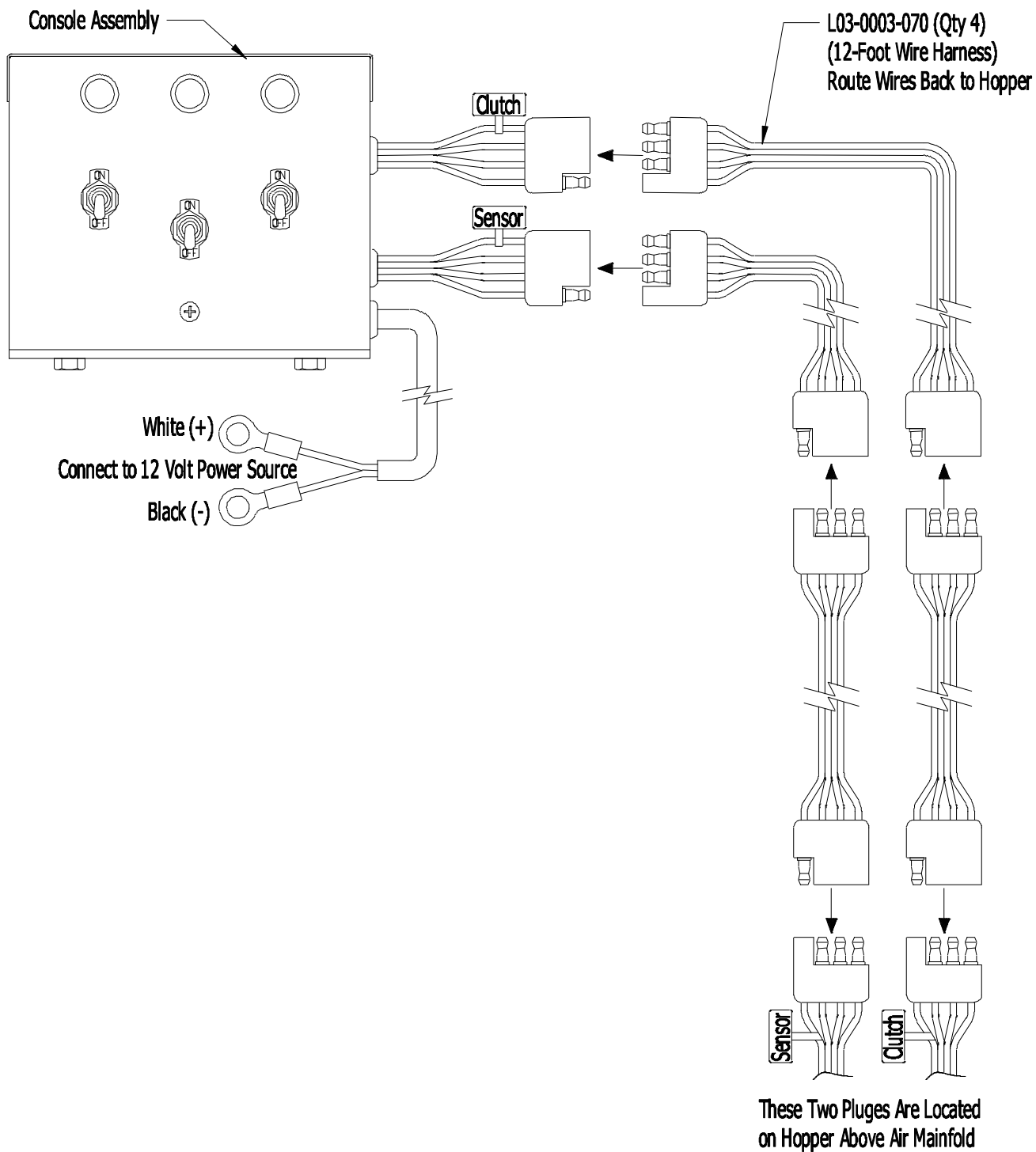

Air Chamber Blank Plates:

Blank Plate (550829-4) is used to block off unused air chamber openings when not needed.

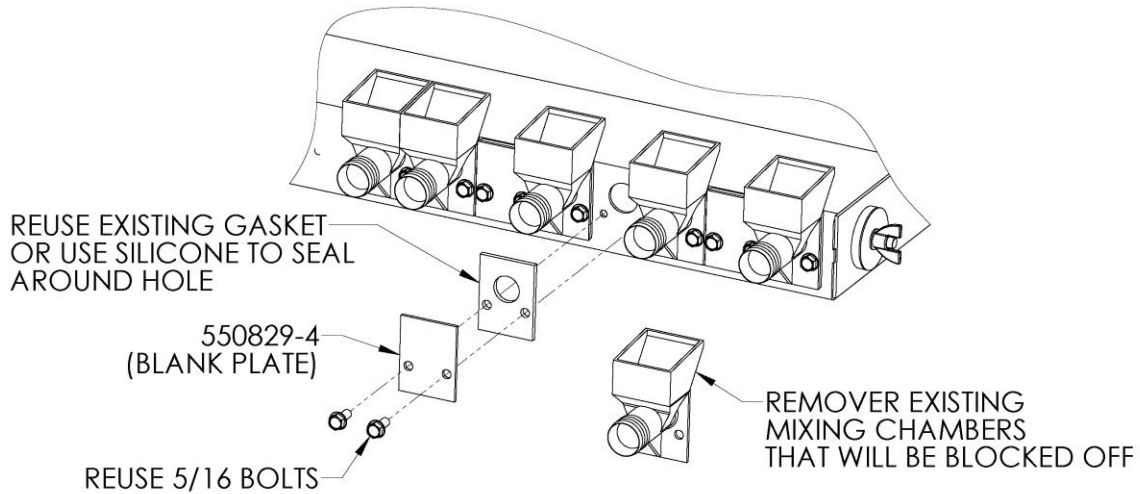

6223-A23

Metering Door Blank Plate:

Blank Plate (62852-20) is used to block off unused metering door openings when not needed.

To remove shaft; First remove sensor hub from shaft, then unbolt bearing flangette by sprocket on metering shaft and pull shaft out. Reassembly by reversing instructions.

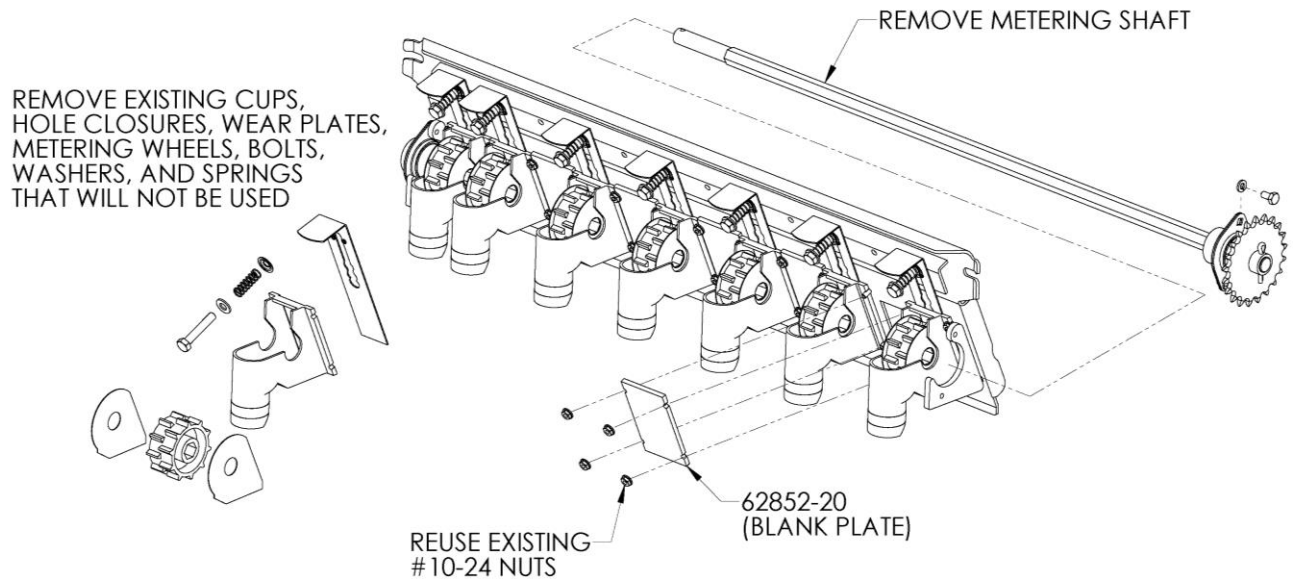

6223-A24

Manual Holder Bracket

Mount manual holder to corner of hopper or convergent location on implement.
Store Operator's manual, Packing List & Rate Chart of convergent access.

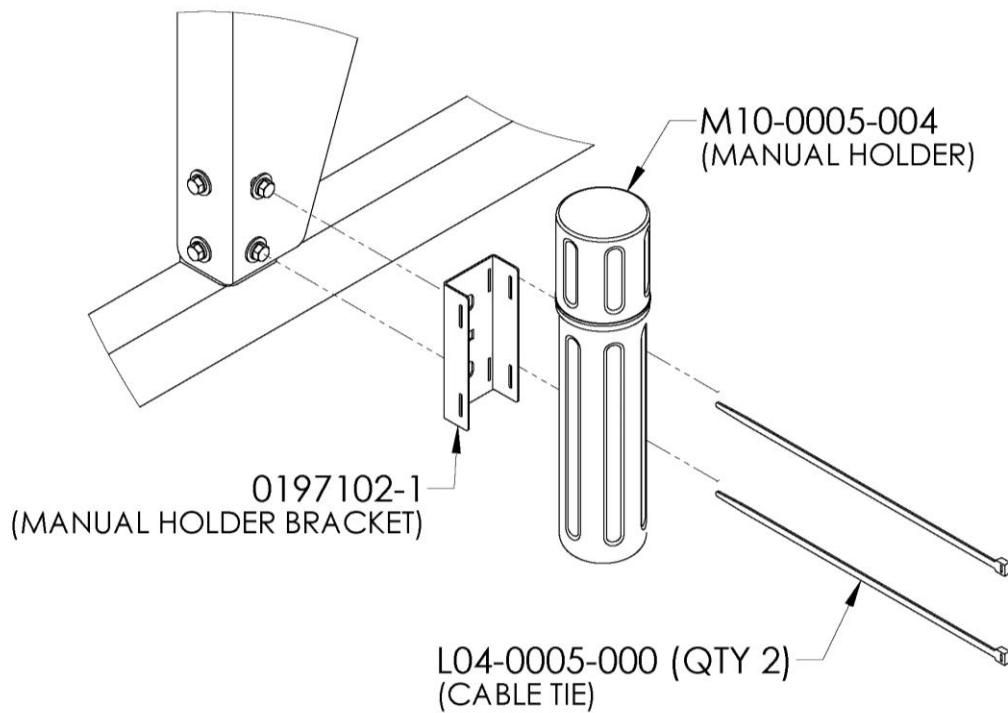

HOLDER-1

Maintenance

Check all bolts for tightness after first two hours of use; check periodically thereafter.

Grease all fittings regularly.

There are **TWO** grease fittings on this hopper. These **must** be greased before use and periodically during use. Locations. See page 14 for locations.

One grease fitting on each 1-inch bearing (D05-1000-010) (Two) located on the 1-inch drive shafts (629066-14).

Lucubrate chains as needed.

Periodically clean intake screen on hydraulic driven blower.

(623116F-S)
April 30, 2018
Printed in the USA