



Parts List & Instructions

815 Rice Lake Street, Owatonna, MN 55060

Phone: 800-443-2476 / 507-451-5430

www.gandy.net / Email: sales@gandy.net

6231DS16F

Orbit-Air Applicator

Implement Mounted Hopper

31 Cu. Ft. (.88m³), 24.8 Bushel, 1395-Lb Chemical Capacity

w/ 16 (1-1/4") Openings, Fertilizer (F) Red Wheels

For Use w/ 1-1/4" I.D. Tubing

Single Shaft No Clutch

12-Volt Electric Motor Driven

(All Parts & Hardware in Place Unless Otherwise Specified)

The Following Parts Are Located Inside Hopper:

- 1..... Packet Containing:Parts & Packing List, Operator's Manual, Rate Chart & Warranty
- 2..... L04-0005-000..... Cable Tie (5/16 x 15-1/4)
- 1..... M10-0005-004..... Manual Holder
- 1..... 0197102-1..... Manual Holder Bracket
- 1..... 6216-D..... Air Pressure Gauge Carton (See Page #8 for Contents)
- 1..... 629069-A..... Parts Carton (See Page #8 for Contents)

Maintenance

Check all bolts for tightness after first two hours of use; check periodically thereafter.

Grease all fittings regularly.

There are **TWO** grease fittings on this hopper. These **must** be greased before use and periodically during use. Locations. See page 14 for locations.

One grease fitting on each 1-inch bearing (D05-1000-010) (Two) located on the 1-inch drive shafts (62185-22).

Lucubrate chains as needed.

Periodically clean intake screen on hydraulic driven blower.

- 1..... S02-0001-034.....Shipping Crate (23/31 CF Hopper)
 Use: 4 Hex Bolt (3/8 x 2-3/4) (C03-0375-111)
 8 Wrought Washer (3/8) (C02-0375-030)
 4 Hex Nut (3/8) (C01-0375-010)
- 1..... 62240-1B.....Hopper, 23/31 CF (Painted Black)
 Use: 2 Sight Window (610851/26)
 4 Rail (610851/27)
 12 Pop Rivet (3/16 x 3/8) (C19-0187-030)
 1 Decal, Important, Metering Wheel (N02-0062-040)
 2 Decal, Caution (N02-0014-010)
 1 Decal, Caution Black on Yellow (N02-0062-050)
 1 Decal, Caution Plug (N02-0062-051)
- 1..... 62241-1.....Roof 31 CF
 Use: 2 Carriage Bolt (3/8 x 1-1/2) (C04-0375-061)
 2 Wrought Washer (3/8) (C02-0375-030)
 2 Whiz Flange Nut (3/8) (C01-0375-030)
 20 Carriage Bolt (5/16 x 3/4) (C04-0312-031)
 20 Whiz Flange Nut (5/16) (C01-0312-030)
 2 Decal, Orbit-Air Small (N02-0001-123) (on sides)
 2 Decal, Gandy Diamond (7-1/2") (N02-0001-124) (on ends)
- 2..... 62240-4.....Bushing Mount
 Use: 2 Carriage Bolt (3/8 x 2) (C04-0375-080)
 2 Whiz Flange Nut (3/8) (C01-0375-030)
- 2..... 62200-22.....Screen Support Bracket
 Use: 4 Carriage Bolt (5/16 x 3/4) (C04-0312-031)
 4 Whiz Flange Nut (5/16) (C01-0312-030)
- 1..... 62240-3.....Cover (For 23/31 Cu ft Hopper)
 Use: 2 Carriage Bolt (3/8 x 1-1/4) (C04-0375-051)
 2 Wrought Washer (3/8) (C02-0375-030)
 2 Jam Lock Nut (3/8) (C01-0375-062)
- 1..... M05-0000-004.....Rubber Latch w/ Keeper
 Use: 4 Pop Rivet (C19-0187-000)
- 2..... 62852-3.....Inner Hinge (Cover)
 Use: 2 Hex Bolt (3/8 x 1) (C03-0375-041)
 4 Jam Nut, Nylon Lock (3/8) (C01-0375-062)
 8 Wrought Washer (3/8) (C02-0375-030)
- 2..... 62852-4.....Outer Hinge (Cover)
 Use: 8 Wrought Washers (3/8) (C02-0375-030)
 4 Jam Nut, Nylon Lock (3/8) (C01-0375-062)
- 2..... 629069-1.....Mounting Base, w/ Holes
 Use: 16 Hex Bolt (3/8 x 1-1/4) (C03-0375-051)
 16 Wrought Washer (3/8) (C02-0375-030)
 16 Lock Washer (3/8) (C02-0375-010)
 16 Whiz Flange Nut (3/8) (C01-0375-030)

- 1..... 62851-8..... Air Chamber, 23/31CF (16-outlet)
 - Use: 2 Hex Bolt (3/8 x 1) (C03-0375-041)
 - 5 Hex Bolt (3/8 x 1-1/4) (C03-0375-051)
 - 5 Wrought Washer (3/8) (C02-0375-030)
 - 5 Lock Washer (3/8) (C02-0375-010)
 - 7 Whiz Flange Nut (3/8) (C01-0375-030)
- 1..... 6216-A..... Air Pressure Switch Wiring Assembly
 - Use: 2 Pan Head TC Screw (#8 x 1/2) (C07-0164-070)
- 1..... 5508242-33..... Gasket, Potting Box
- 1..... L10-0016-010..... Potting Box
 - Use: 2 Pan Head TC Screw (#8 x 1/2) (C07-0164-070)
- 16..... M05-0829-300..... Gasket, Mixing Chambers
- 16..... M10-0055-060..... Mixing Chamber (For 1-1/4 inch I.D. Tubing)
 - Use: 32 Hex Head Self-Tap Bolt (5/16 x 3/4) (C03-0312-032)
- 2..... M05-2000-000..... Rubber Plug, 2-inch (For Air Chamber Clean Out)
- 1..... 62851-32..... Angle Support For Air Chamber & Blower
- 1..... 628720-18..... Clean-Out Chute, 4-inch
 - Use: 1 Hex Nut (5/16) (C01-0312-010)
 - 1 Lock Washer (5/16) (C02-0312-020)
 - 1 Wrought Washer (5/16) (C02-0312-030)
- 1..... M05-3000-000..... Rubber Plug, 3-inch (Hopper Clean Out)
- 1..... 62240-10..... Angle Clamp, Tubes (For 23/31 CF)
 - Use: 4 Foam Clamp Strip 9-1/2 Long (62851-16)
 - 5 Hex Bolt (5/16 x 2-1/4) (C03-0312-091)
 - 5 Lock Nut, Nylon (5/16) (C01-0312-040)
- 1..... 5608226..... Bar Clamp, Plastic Tubing (For 23/31 Cu Ft Hopper)
 - Use: 4 Foam Clamp Strip 9-1/2 Long (62851-16)
- 2..... 62852-16..... Mounting Bracket, Platform (23/31 CF)
 - Use: 4 Carriage Bolt (5/16 x 3/4) (C04-0312-031)
 - 4 Whiz Flange Nut (5/16) (C01-0312-030)
- 1..... 62851-10..... Platform (For 23/31 CF)
 - Use: 3 Grip Tape (3 x 48-1/2 Long) (62851-15)
- 1..... 62851-37..... Angle Support (For 23/31 CF Platform)
 - Use: 4 Carriage Bolt (5/16 x 3/4) (C04-0312-031)
 - 4 Whiz Flange Nut (5/16) (C01-0312-030)
- 1..... 62851-67..... Clear Windshield (For 23/31 CF)
 - Use: 6 Hex Bolt (1/4 x 3/4) (C03-0250-030)
 - 6 Lock Washer (1/4) (C02-0250-010)
 - 6 Wrought Washer (5/16) (C02-0312-030)
 - 6 Whiz Flange Nut (1/4) (C01-0250-030)
- 4..... 62851-5..... Screen (For 23/31 CF)
- 1..... 62240-8..... Bracket Long Fan Support
 - Use: 2 Hex Bolt (3/8 x 1-1/4) (C03-0375-051)
 - 2 Wrought Washer (3/8) (C02-0375-030)
 - 2 Lock Washer (3/8) (C02-0375-010)
 - 2 Whiz Flange Nut (3/8) (C01-0375-030)
- 1..... 62240-9..... Bracket Short Fan Support
 - Use: 2 Hex Bolt (3/8 x 1-1/4) (C03-0375-051)
 - 2 Wrought Washer (3/8) (C02-0375-030)
 - 2 Lock Washer (3/8) (C02-0375-010)
 - 2 Whiz Flange Nut (3/8) (C01-0375-030)

- 1..... L01-0012-007.....Electric Motor, 12 Volt Stature
Use: 4 Hex Bolt (1/4 x 3/4) (C03-0250-030)
4 Lock Washer (1/4) (C02-0250-010)
- 1..... 629068-5.....Mounting Plate, Electric Stature Motor
Use: 2 Hex Bolt (3/8 x 1-1/4) (C04-0375-051)
2 Lock Washer (3/8) (C02-0375-010)
2 Wrought Washer (3/8) (C02-0375-030)
2 Whiz Flange Nut (3/8) (C01-0375-030)
- 1..... 62240-60.....Mounting Bracket, Electric Motor
Use: 2 Hex Bolt (5/8 x 4) (C03-0625-161)
2 SAE Washer (5/8) (C02-0625-020)
2 Lock Washer (5/8) (C02-0625-010)
2 Hex Nut (5/8) (C01-0625-010)
- 1..... G01-0018-030Sprocket 18-Tooth (5/8 Bore)
Use: Key (3/16 x 7/8) (24078179-11)
- 1..... F02-0041-038.....Roller Chain #41 (38 Rollers)
Use: 1 Connector Link #41 (F02-0041-001)
- 1..... 62240-5.....Chain Guard
Use: 4 Carriage Bolt (1/4 x 5/8) (C04-0250-020)
4 Whiz Flange Nut (1/4) (C01-0250-030)
- 1..... 62240-6.....Strap Long Mount
Use: 1 Hex Bolt (3/8 x 1-1/4) (C03-0375-051)
1 Wrought Washer (3/8) (C02-0375-030)
1 Lock Washer (3/8) (C02-0375-010)
1 Whiz Flange Nut (3/8) (C01-0375-030)
- 1..... 62240-7.....Strap Short Mount
Use: 1 Hex Bolt (3/8 x 1-1/4) (C03-0375-051)
1 Wrought Washer (3/8) (C02-0375-030)
1 Lock Washer (3/8) (C02-0375-010)
1 Whiz Flange Nut (3/8) (C01-0375-030)
- 1..... F02-0041-062.....Roller Chain #41 (62 Rollers)
Use: 1 Connector Link #41 (F02-0041-001)

1..... **Jack Shaft Assembly 62240-D**

- 1..... **62200-23.....Drive Bearing Housing**
Use: 1 Carriage Bolt (3/8 x 1-1/4) (C04-0375-051) (Not Part of 62240-D)
1 Wrought Washer (3/8) (C02-0375-030) (Not Part of 62240-D)
1 Lock Washer (3/8) (C02-0375-010) (Not Part of 62240-D)
1 Hex Nut (3/8) (C01-0375-010) (Not Part of 62240-D)
 - 2..... D05-1000-050Bearing 1-inch Bore w/Set Screw
Use: 4 Hex Bolt (5/16 x 3/4) (C03-0312-030)
4 Lock Washer (5/16) (C02-0312-010)
 - 1..... 629069-2.....Drive Shaft (1-inch x 8 Long)
Use: 2 SAE Washer (1-inch) (C02-1000-020)
1 Cotter Pin (3/16 x 1-1/2) (C20-0187-040)
 - 1..... 62851-33.....Bushing (1-1/4 x 9/16 Long)
 - 1..... 62853-13.....Sprocket, 24-Tooth (1-nch Bore x 1-1/2 Hub)
Use: 1 Cotter Pin (3/16 x 1-1/2) (C20-0187-040)
 - 1..... 628833-1.....Sprocket, 16-Tooth (1 Inch Bore x 1-1/2 Hub)
Use: 2 Socket Set Screw (1/4 x 1/4) (C06-0250-020) (Replacement Part)
1 Key (1/4 x 1-3/8) (5508336-6)
-

1 5508442-35 Magnetic Hub, 5/8 Bore (**Installed on Metering Door Shaft**)
Use: 1 Cotter Pin (3/16 x 1-1/4) (C20-0187-030)

1 6216-F Metering Door Assembly, 16 (1-1/4) Red Wheels:

1 62851-24 Meter Door, 16-Out
Use: 2 J-Bolt (5/16) (C16-0312-020)
2 Wrought Washer (5/16) (C02-0312-030)
2 Hex Nut (5/16) (C01-0312-010)

4 Ft M05-0125-050 Rubber Strip w/ Adhesive (1/8 x 1/2)

16 M10-0001-100 Metering Cup, 1-1/4
Use: 36 Whiz Flange Nut (3/16) (C01-0187-030)

16 62851-76 Hole Closures, Slotted
Use: 16 Comp Spring (E00-0420-012)
16 Extruded Washer (628720-20)
16 SAE Washer (5/16) (C02-0312-020)
16 Hex Bolt (5/16 x 1-3/4 **Stainless**) (C03-0312-071)

16 M10-0001-040 Metering Wheel Red

32 62851-72 Wear Plate, Stainless

1 62851-3 Shaft (41-15/16 x 5/8 Hex)

1 62851-4 Center Bearing, Plastic (1 Inch Bore)

1 22904-8 Journal Line Shaft (For Center Bearing)

2 62851-26 Bushing (1 Inch O.D. x 1/2)

2 63861-7 Bearing, Plastic (5/8 Bore)

6 09074690-4 Flangette, Bearing (For 63861-7)
Use: 6 Hex Bolt (1/4 x 3/4 **Stainless**) (C03-0250-015)
6 Lock Washer (1/4 **Stainless**) (C02-0250-012)
6 Whiz Flange Nut (1/4 **Stainless**) (C01-0250-032)

1 62851-41 Sprocket 21-Tooth, (5/8 Bore)
Use: 1 Cotter Pin (3/16 x 1-1/4) (C20-0187-030)

Hydraulic Blower Assembly

1	62167-P8LH	Blower Assembly w/out Hydraulic Hoses
1	B56-08636	Housing Set, Front & Rear (Black Plastic) Use: 14 Hex Bolt (1/4 x 3/4) (C03-0250-030) 28 SAE Washer (1/4) (C02-0250-020) 14 Lock Nut, Nylon (1/4) (C01-0250-040)
1	5608636-4.....	Back-Up Plate Use: 4 Carriage Bolt (3/8 x 1-1/4) (C04-0375-051) 4 Lock Nut, Nylon (3/8) (C01-0375-041)
1	62167-2.....	Mount, Blower (Plastic w/Coupler) Use: 1 Decal, Warning Rotating Parts (N02-0055-010) 1 Decal, Important Hydraulic Motor (N02-0062-043) 1 Decal, Black on Yellow (N02-0062-050)
1	L01-0034-004.....	Fan, Impeller Use: 1 Bushing (1-inch JA Bore) (L01-0033-002)
1	5408320-25.....	Key, Fan Shaft (1/4 x 1)
1	62167-3.....	Shaft (6 Inch Long)
1	28122-49.....	Key, for Coupler (3/16 sq. x 1)
1	K18-M024-000.....	Coupler (9/16 x 7/8)
	Replacement Parts	(K18-M024-003 Black Plastic Coupler Sleeve) (5508230-5 1/8 x1 Key) (K18-M024-004 Coupler for 9/16 Shaft on Hyd Motor) (K18-M024-005 Coupler for 7/8 Shaft on End of Fan Shaft)
1	K01-0045-003	Hydraulic Motor, 8-GPM Casappa Use: 2 Carriage Bolt (3/8 x 1-1/4) (C04-0375-051) 2 Washer, Motor Side, Stainless (62164-2) 2 Lock Nut, Nylon (3/8) (C01-0375-041)
2	D05-1000-030	Bearing & Locking Collar (For 1-inch Shaft)
4	D10-1000-011	Flangette, Round Use: 6 Carriage Bolt (5/16 x 1) (C04-0312-040) 6 Lock Washer (5/16) (C02-0312-010) 6 Hex Nut (5/16) (C01-0312-010)
1	5608231-3.....	Screen, Blower Use: 3 Pan Head Sheet Screw (#10 x 3/4) (C07-0187-090)
1	5508336-7.....	Guard, Blower Shaft Use: 2 Hex Head Self-Tap Bolt (5/16 x 3/4) (C03-0312-032)

**The following hydraulic hoses are shipped connected to blower assembly.
(These are not part of blower assembly)**

1	K02-0375-024	Hydraulic Hose, 3/8 x 24" (Case Drain)
1	62167-H	Hydraulic Hose & Block Assembly
2	K02-0500-120	Hydraulic Hose, 1/2 x 120"
2	K02-0500-014	Hydraulic Hose, 1/2 x 14" w/ O-Ring Fitting on One End
1	62113	Hydraulic By-Pass Block Assembly w/Check Valve
1	K05-CV10-200.....	Check Valve
1	6296-1.....	Hydraulic By-Pass Block

The Following Parts & Two Cartons Are Shipped Inside Hopper:

- 1..... 0197102-1..... Manual Holder Bracket
- 2..... L04-0005-000..... Cable Tie (5/16 x 15-1/4)
- 1..... M10-0005-004..... Manual Holder

1..... 6216-D..... Air Pressure Gauge Carton Containing: (inside Hopper)

- 1..... K17-P734-004..... Air Pressure Gauge 4-inch
- 2..... K04-0250-375..... Adaptor, Plastic, 1/4 MPT x 3/8 HB
- 1..... 62851-46..... Mounting Bracket, Air Pressure Gauge
- 1..... 62851-47..... Clamp Bracket
- 4.5 Ft... M06-0375-000..... Tubing 3/8 I.D. x 1/8 Wall (One Piece 54 Inches long)
- 1..... C03-0312-041..... Hex Bolt (5/16 x 1)
- 1..... C01-0312-030..... Whiz Flange Nut (5/16)

1..... 629069-A..... Parts Carton Containing The Following:

1..... 629068-B..... Enclosed Console Assembly, 2 Lights, 1 Switch

- 1..... 5508338-23..... Enclosed Console, Front
- 1..... 5508338-24..... Enclosed Console, Back
 - Use: 4 Pan Head Sheet Screw (#10 x 5/16) (C07-0187-040)
 - 2 Hex Bolt (1/4 x 3/4) (C03-0250-30) **(in Place)**
 - 2 Whiz Flange Nut (1/4) (C01-0250-030) **(in Place)**
- 1..... C07-0164-051..... Phillips Head Screw (#8-32 x 3/8)
- 1..... C01-0164-040..... Kep Nut (#8/32)
- 3..... M05-2858-000..... Rubber Grommet (3/8 I.D.)
- 3..... J03-0500-000..... Hole Plug, 1/2
- 1..... L05-0008-000..... Amber Light
- 1..... L05-0008-020..... Green Light
- 1..... L05-0001-050..... Switch, Toggle On/Off (#90-001)
- 1..... 5808338-1..... Molded Connector, Female 8-inch w/Terminal
- 1..... L03-0015-000..... Fork Terminal, Yellow
- 2..... L03-0005-000..... Wire Connector, Blue
- 1..... 62853-47..... Power & Ground Wire, 10 ga x 12 Feet
- 1..... 629068-2..... Electric Rip Cord, 10 ga x 12 Foot
 - Use: 2 Wire Connector, Yellow (L03-0005-010) **(in Hardware Bag)**

- 1..... L03-0003-070..... Molded Connector, 4 Contact, M & F, 144-inch Wire
- 12 Ft..... L05-0011-062..... Flex Guard Loom
- 4..... 550829-4..... Blank Plate, Air Chamber
- 4..... 62852-20..... Blank Plate, Metering Door
- 8..... 550828-3..... Bar Clamp
- 8..... 09071598-5..... Stud Bolt (5/8 x 13-1/2)
 - Use: 16 Lock Washer (5/8) (C02-0625-010) **(in Hardware Bag)**
 - 16 Hex Nuts (5/8) (C01-0625-010) **(in Hardware Bag)**

1..... 629069-H..... Hardware Bag Containing: (in Parts Box)

- 16..... C01-0625-010..... Hex Nut (5/8)
- 16..... C02-0625-010..... Lock Washer (5/8)
- 2..... L03-0005-010..... Wire Connector, Yellow

Cover Hinge Bolt Assembly

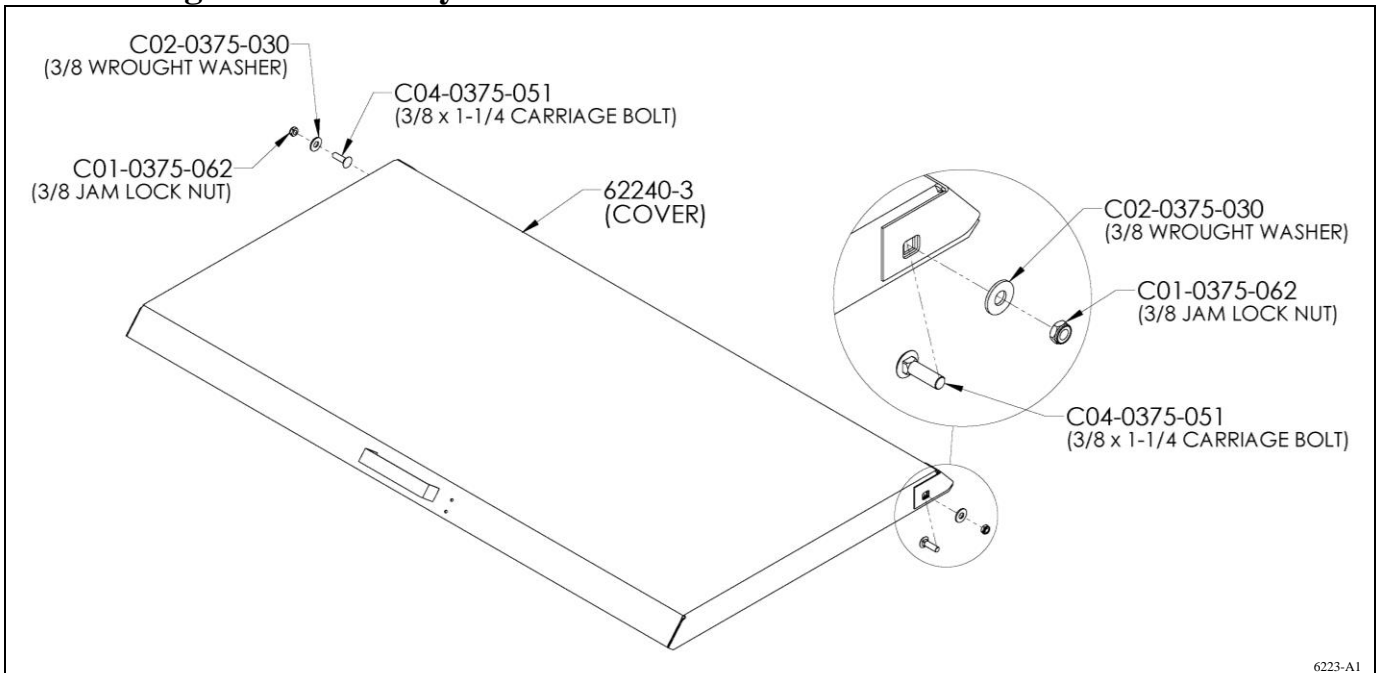

Roof Hinge Bolt Assembly

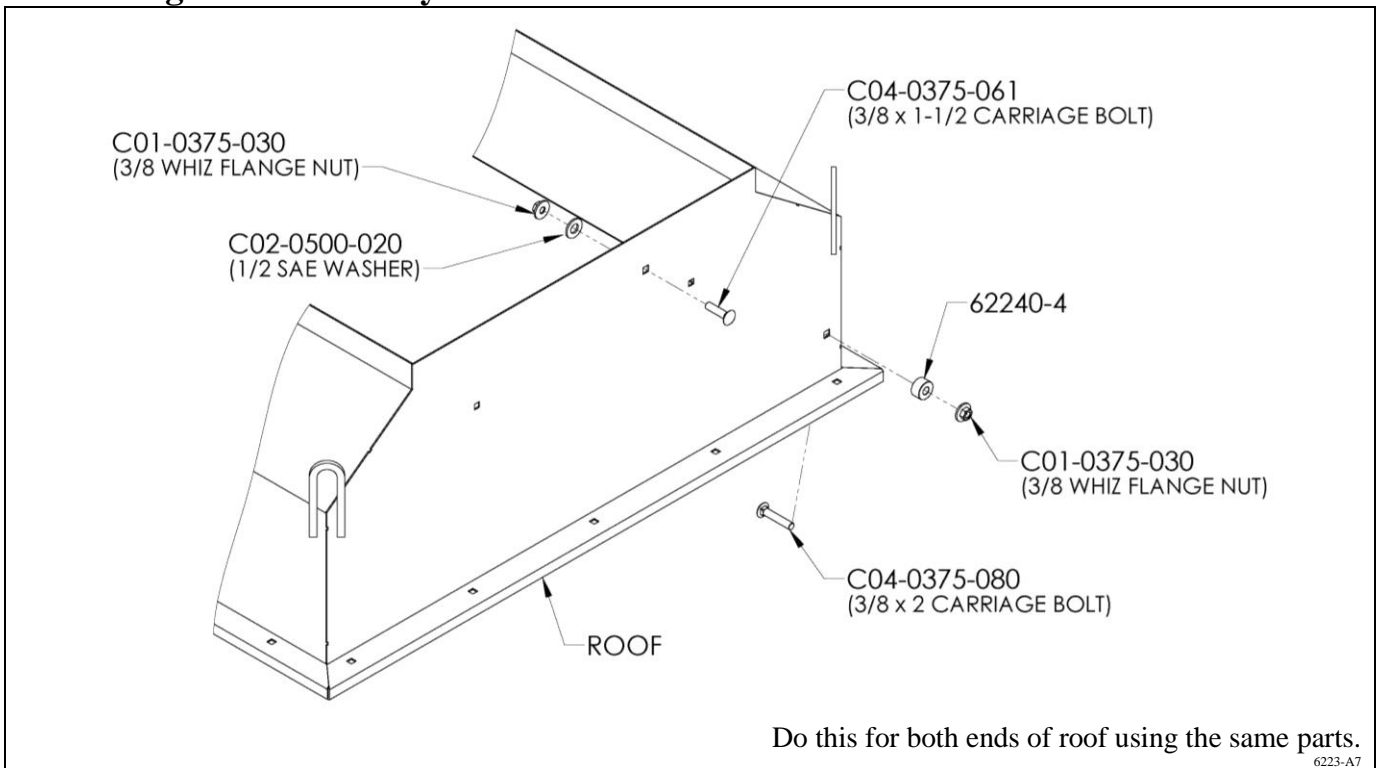

Roof Assembly

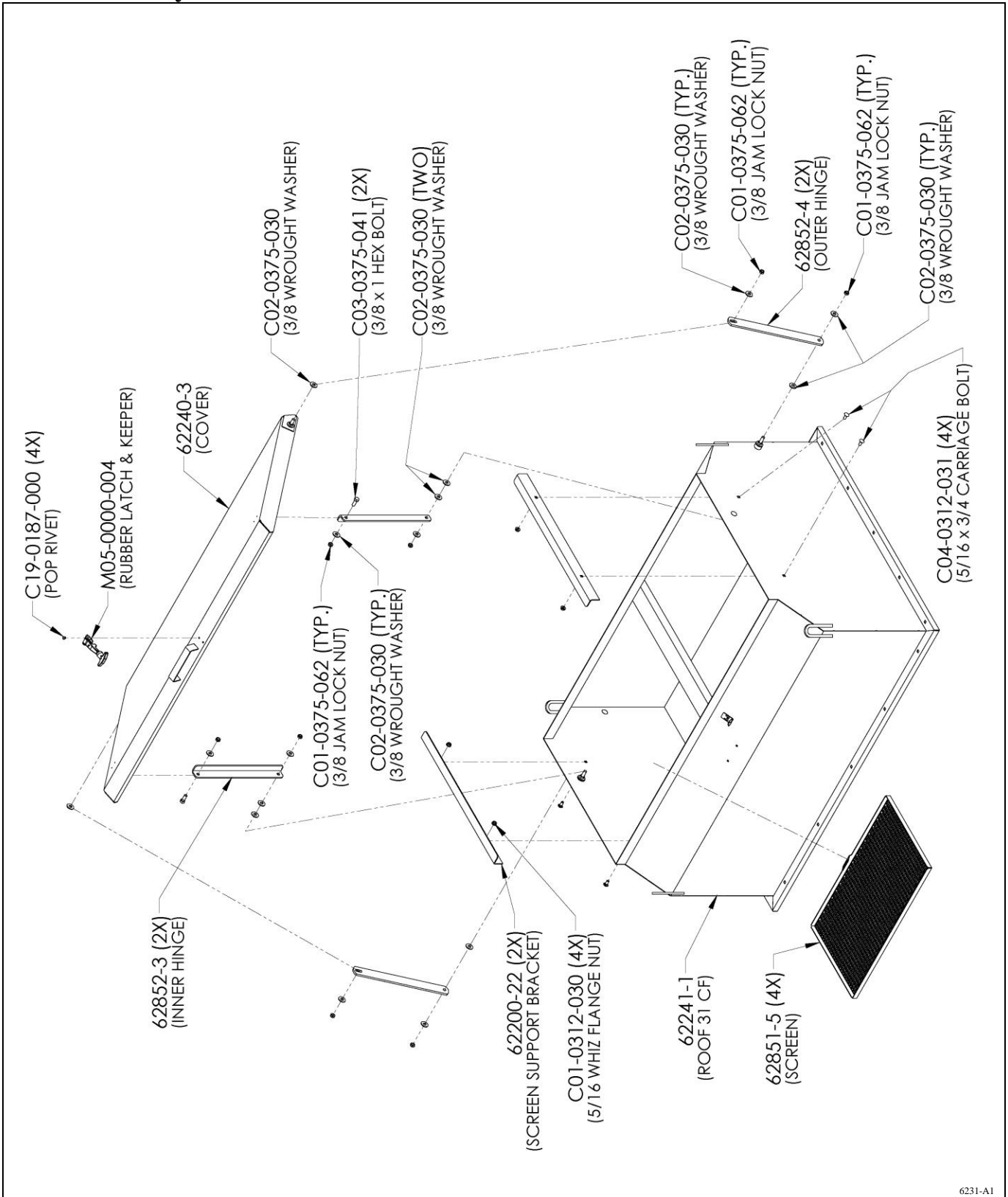

6231-A1

Sight Window Assembly

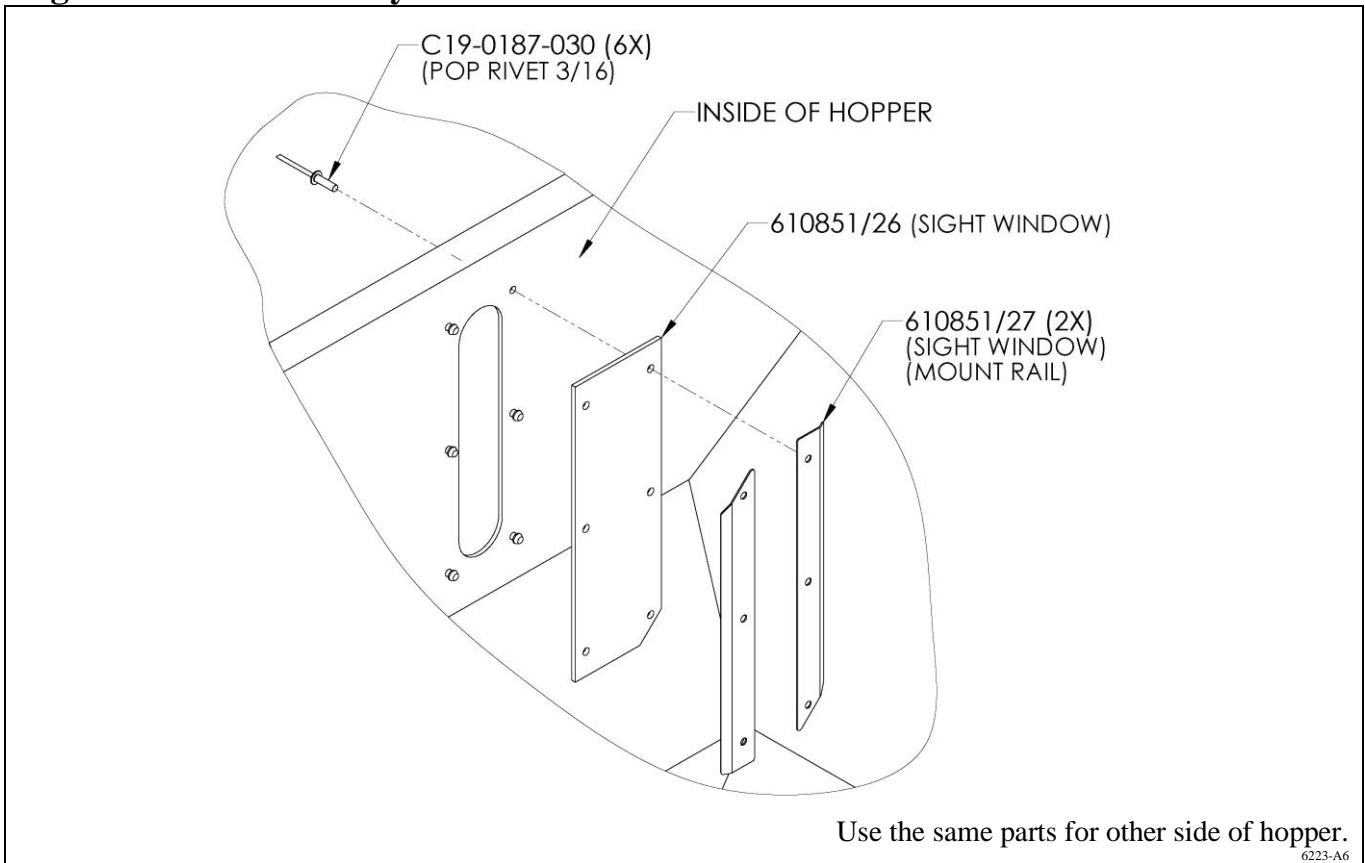

Roof to Hopper Assembly

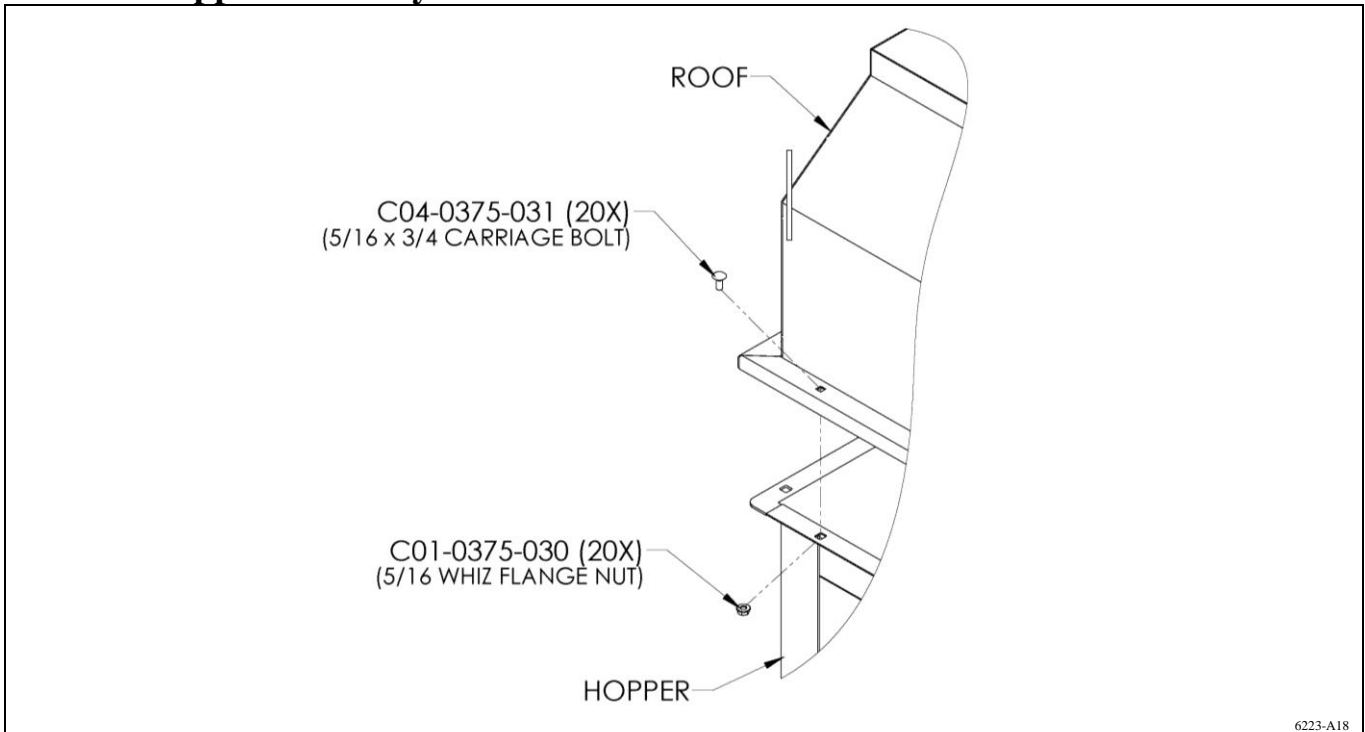

Hopper Assembly

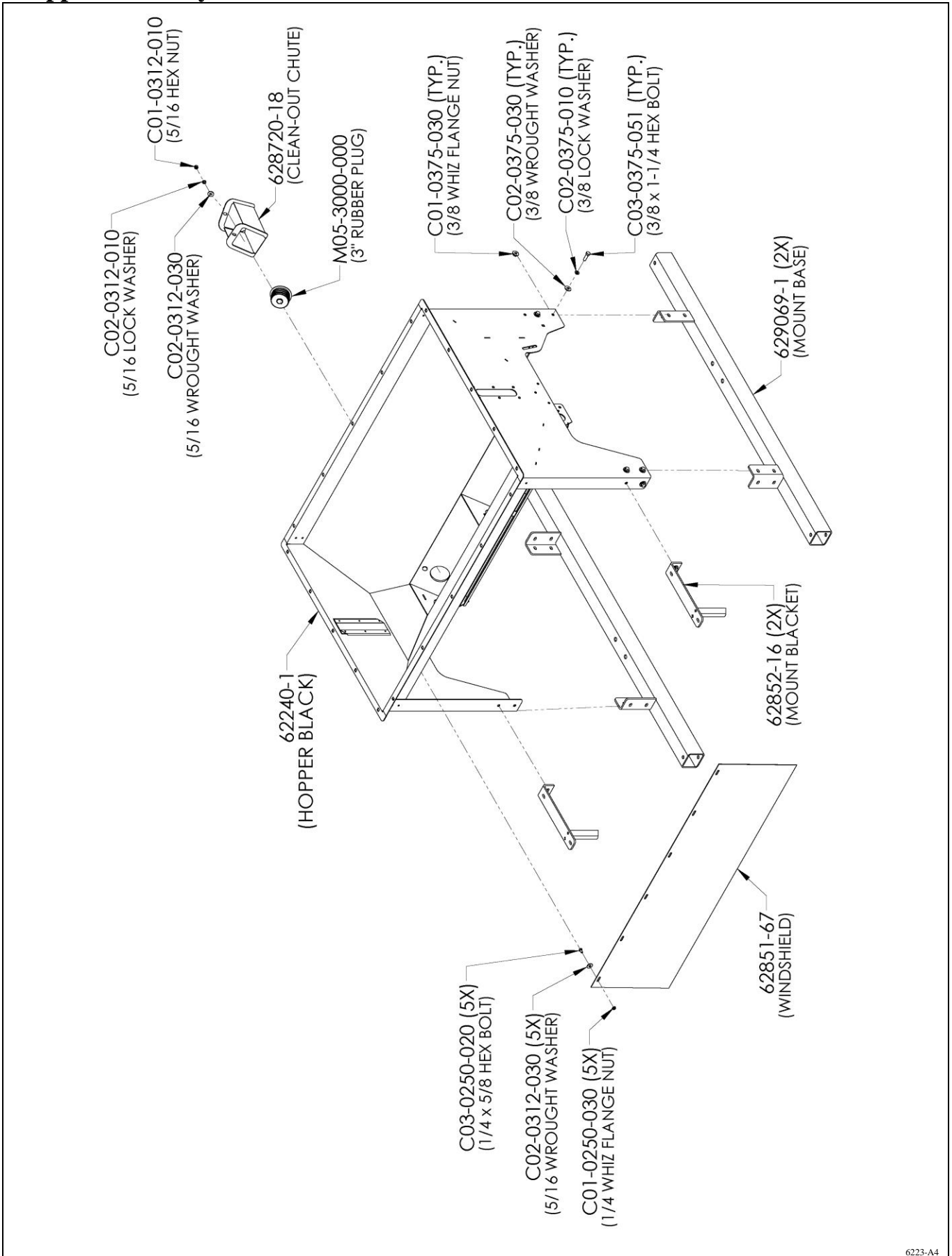

6223-A4

Hopper Assembly

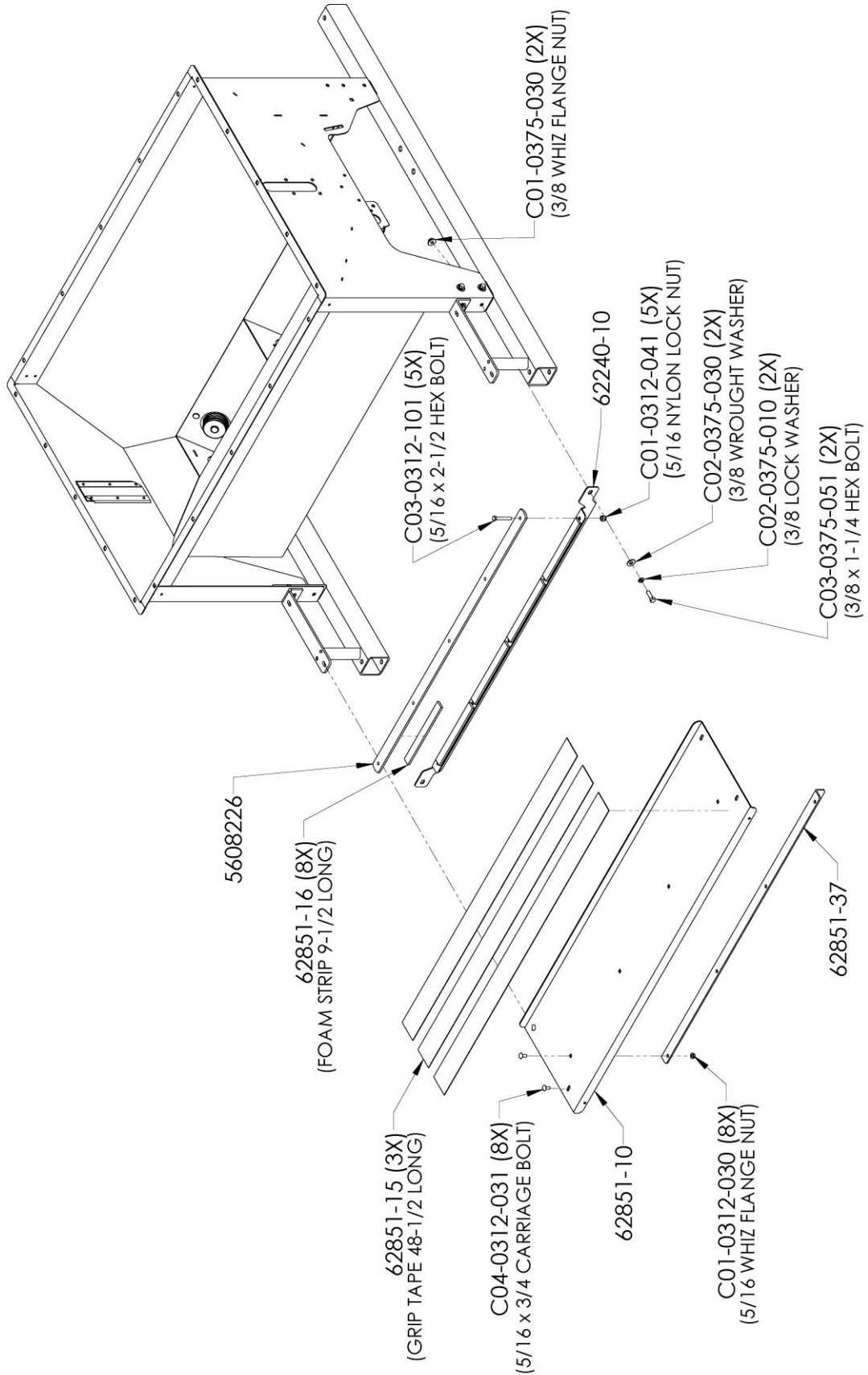

6223-A22

Drive Shaft Assembly

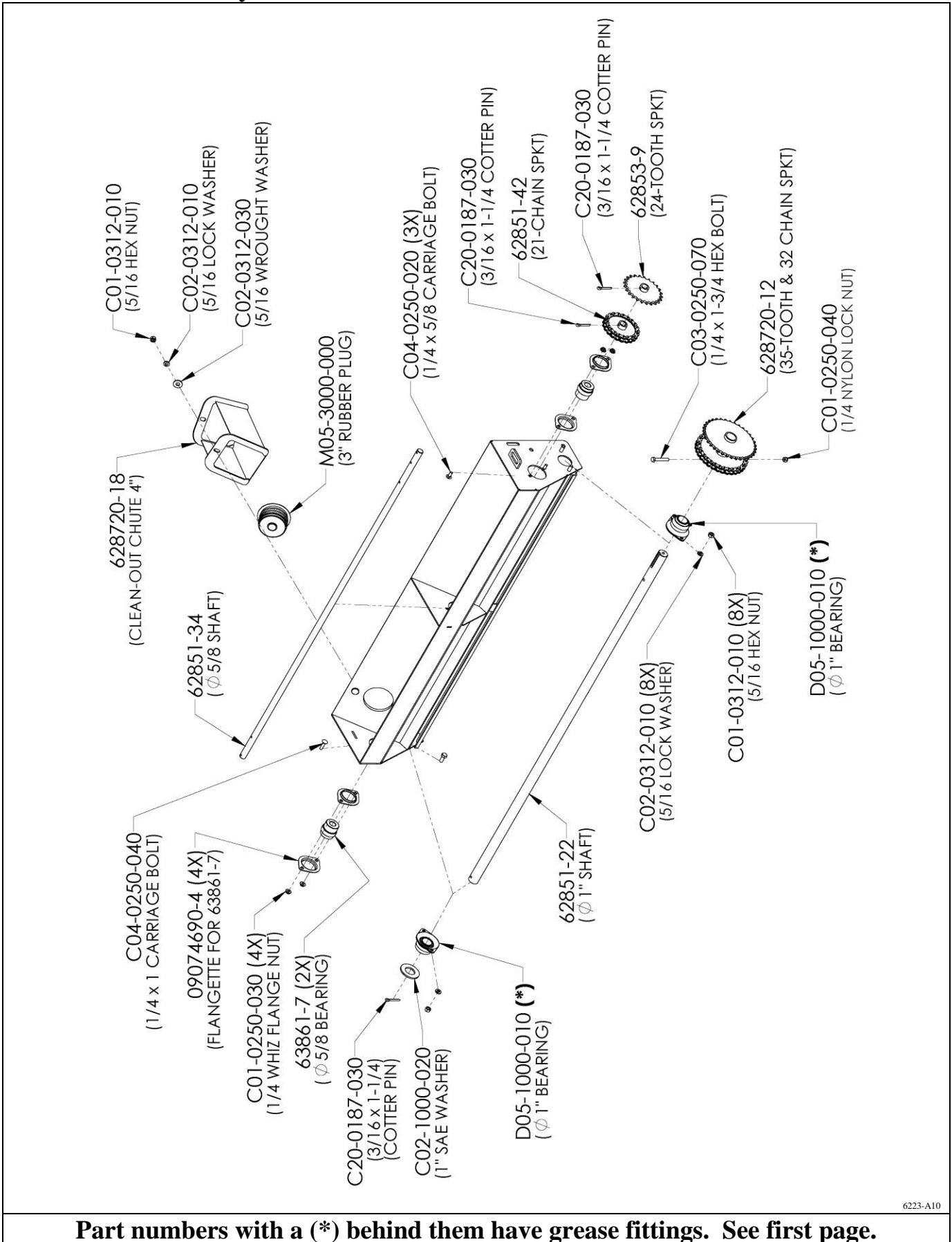

6223-A10

Zero-Max Assembly

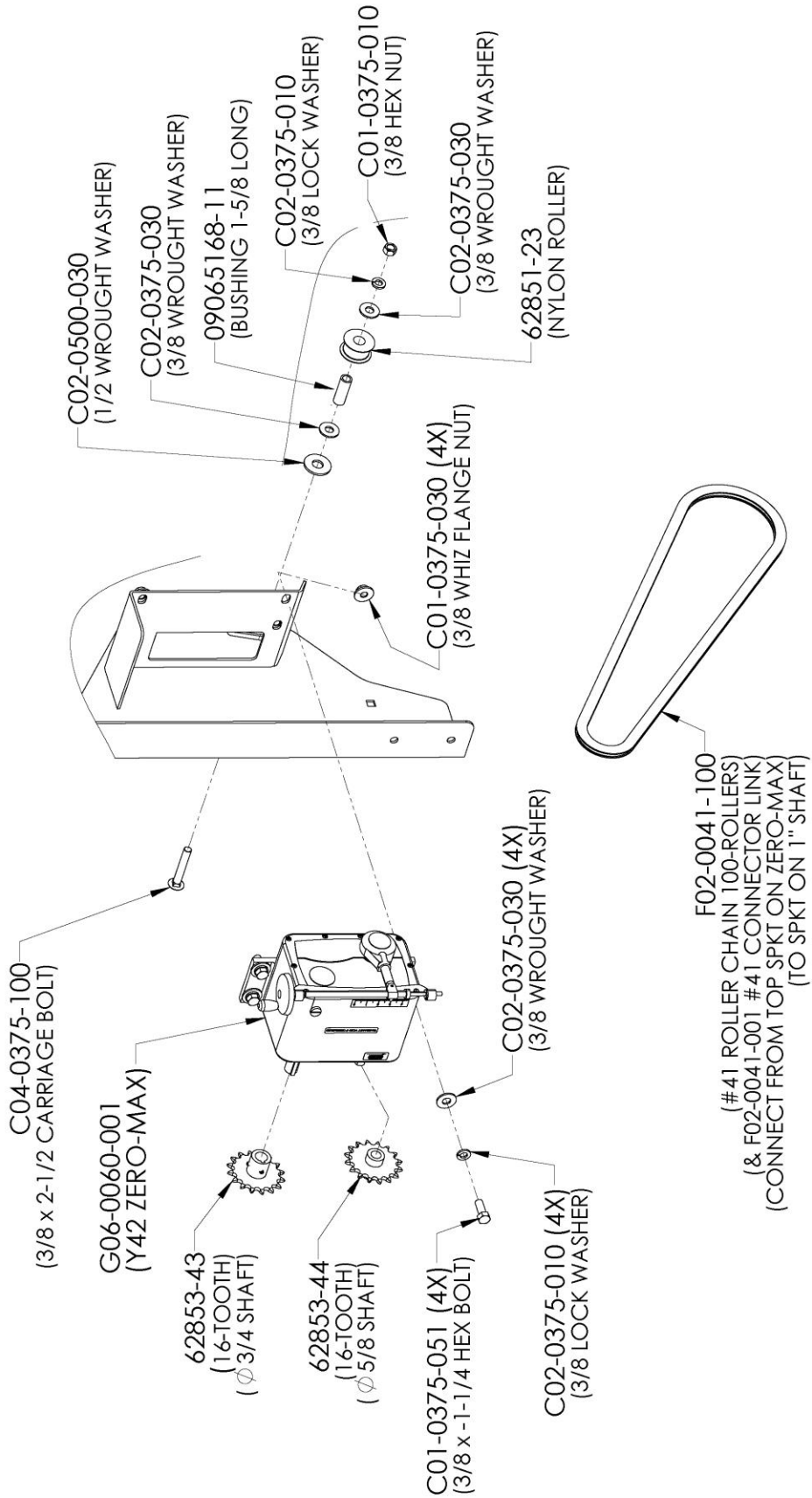

Jack Shaft Assembly (62240-D)

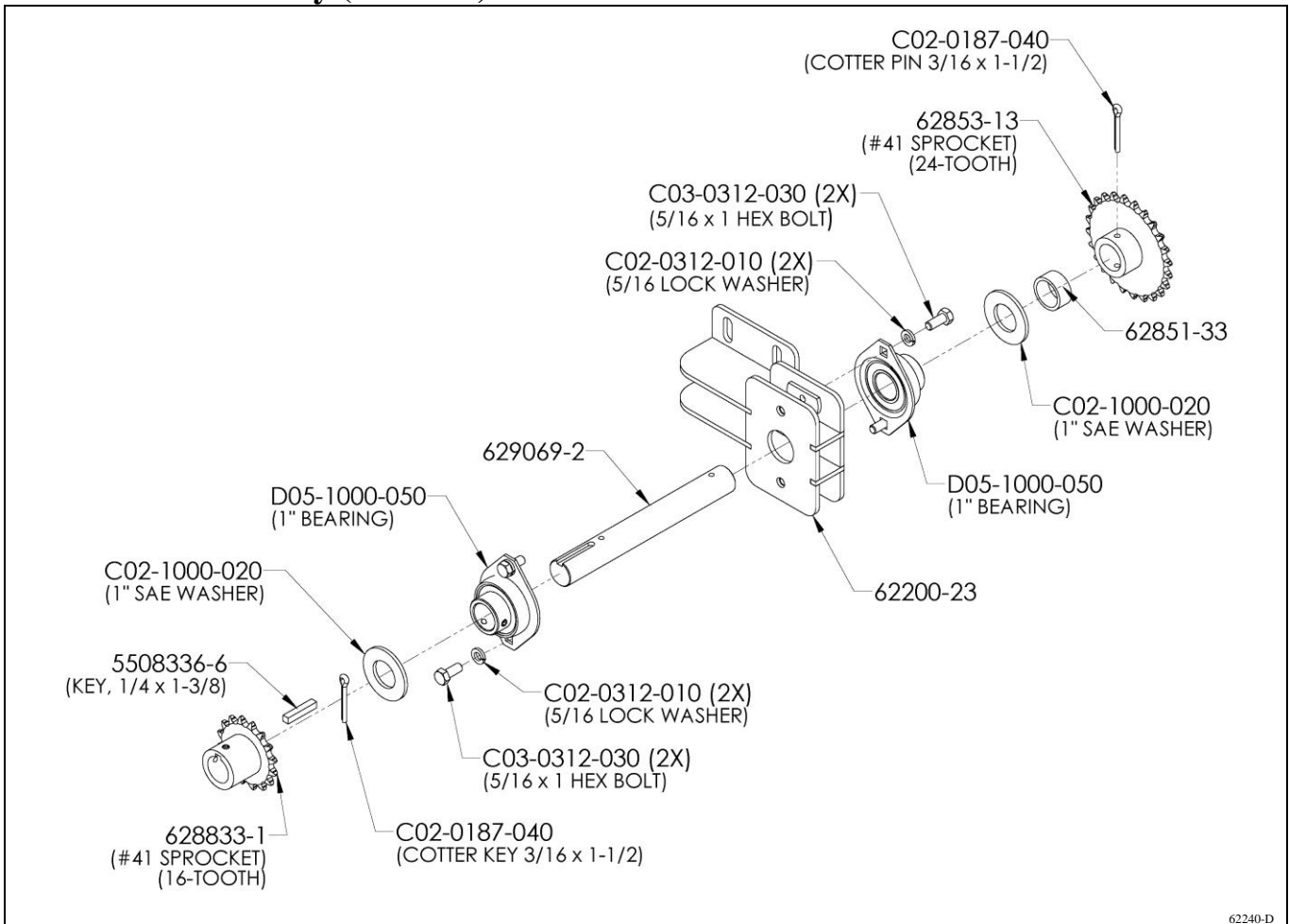

62240-D

12-Volt Motor Assembly

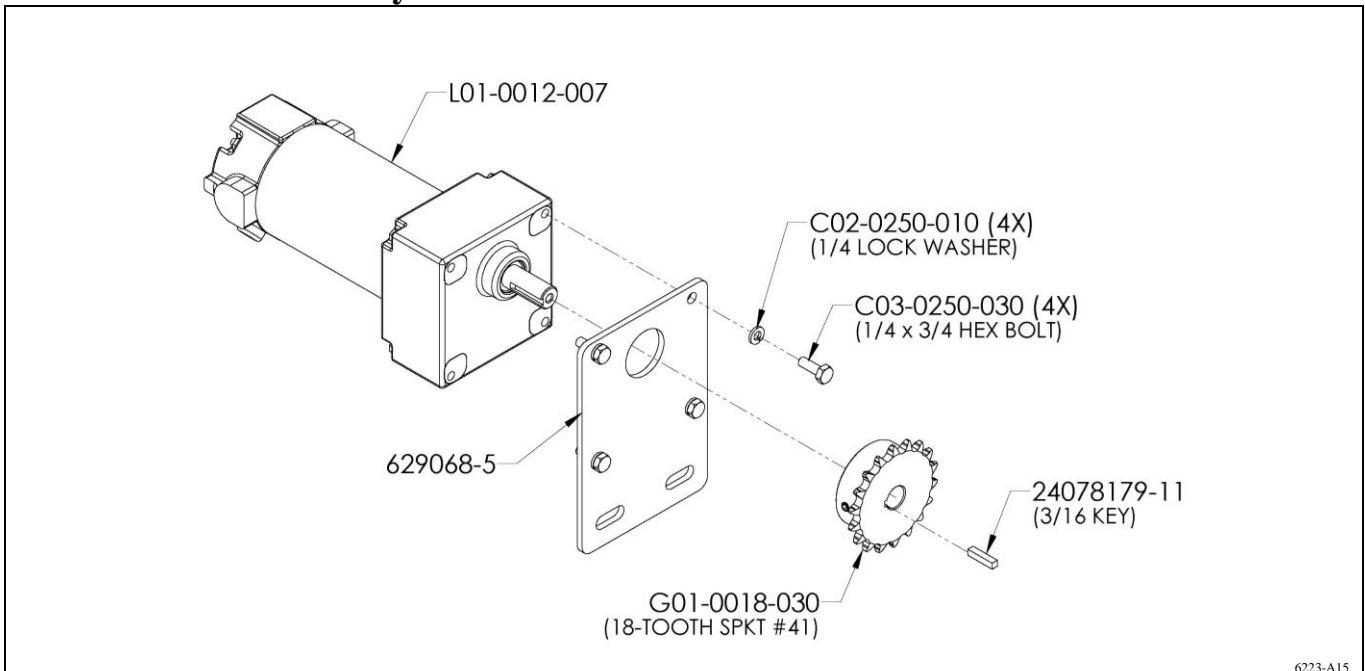

6223-A15

Jack Shaft to Hopper Assembly

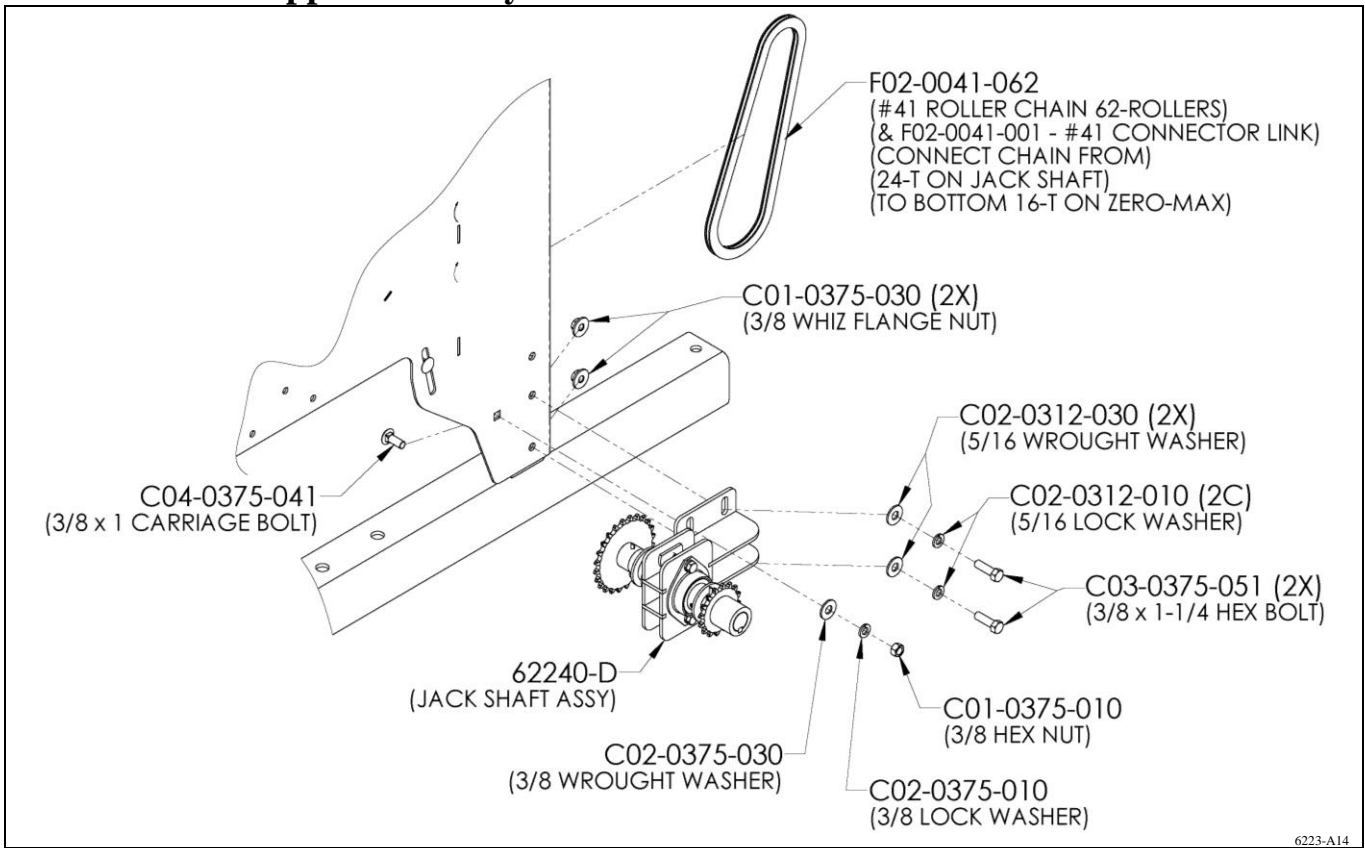

Chain Guard Assembly

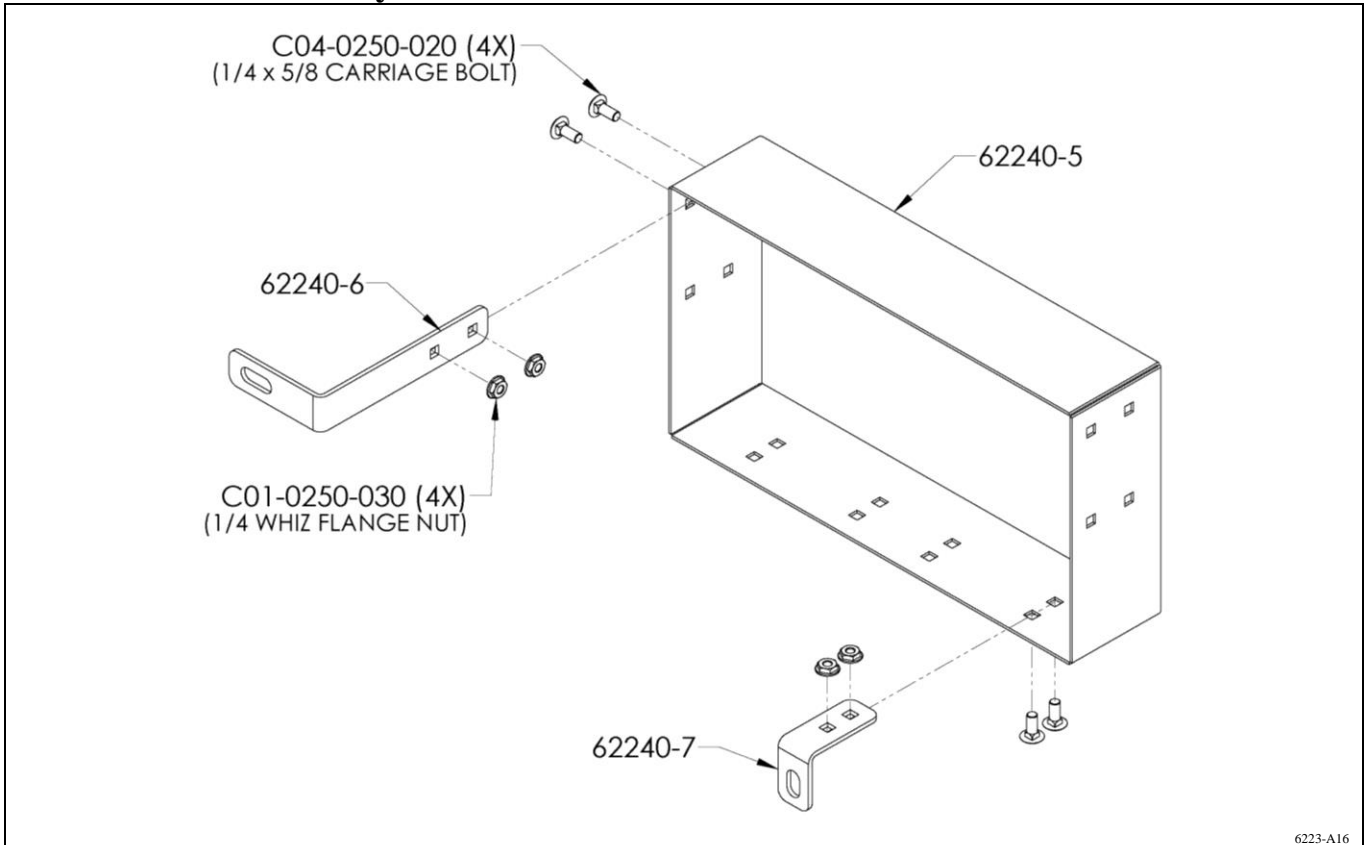

12-Volt Drive Assembly

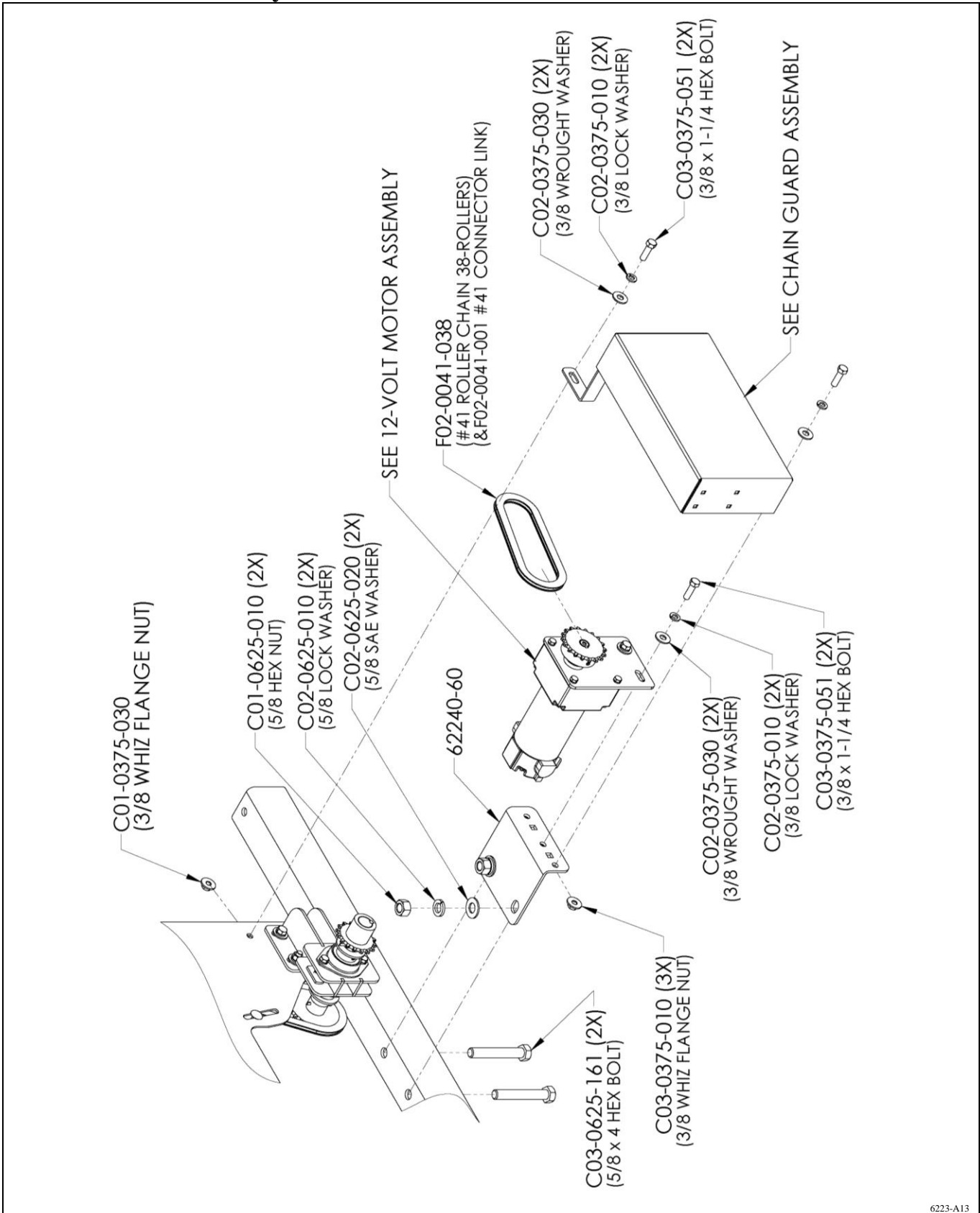

6223-A13

Metering Door Assembly (6216-F)

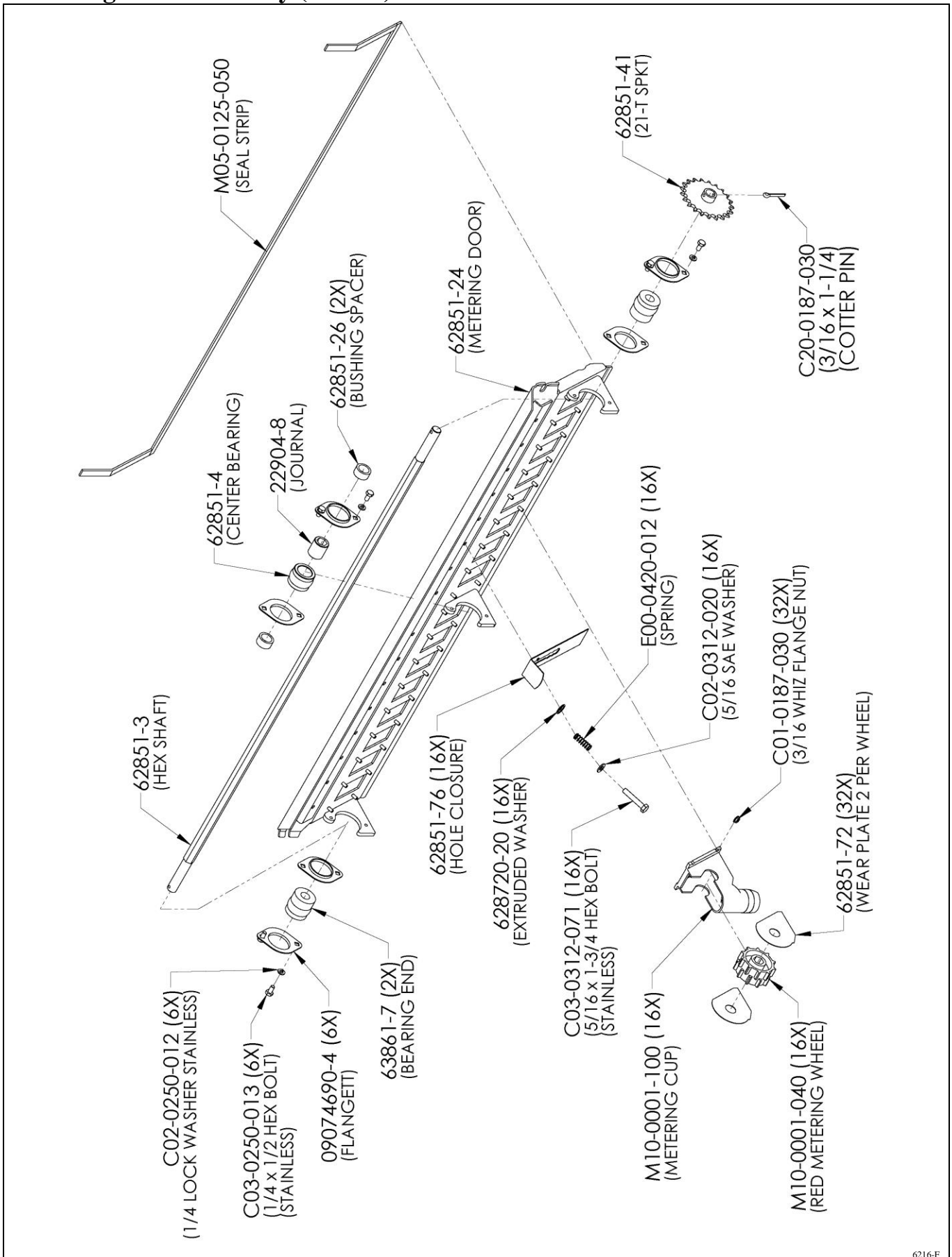

6216-F

Fastening Metering Door in Place (use one J-Bolt on each end of metering door)

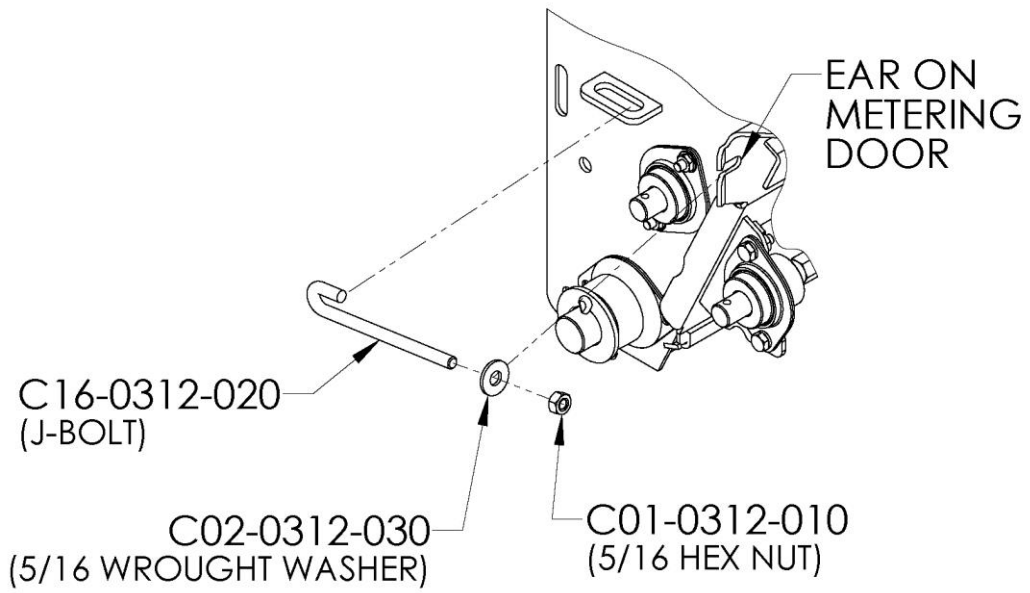

J-bolt shown in place.

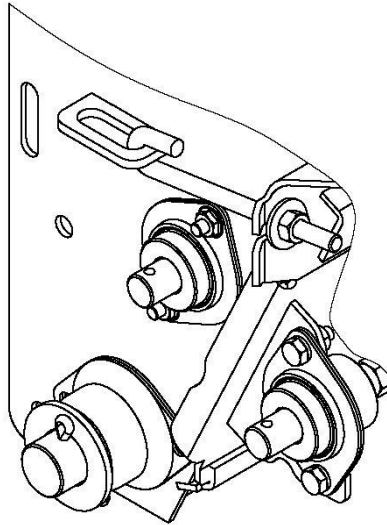

Air Chamber Assembly

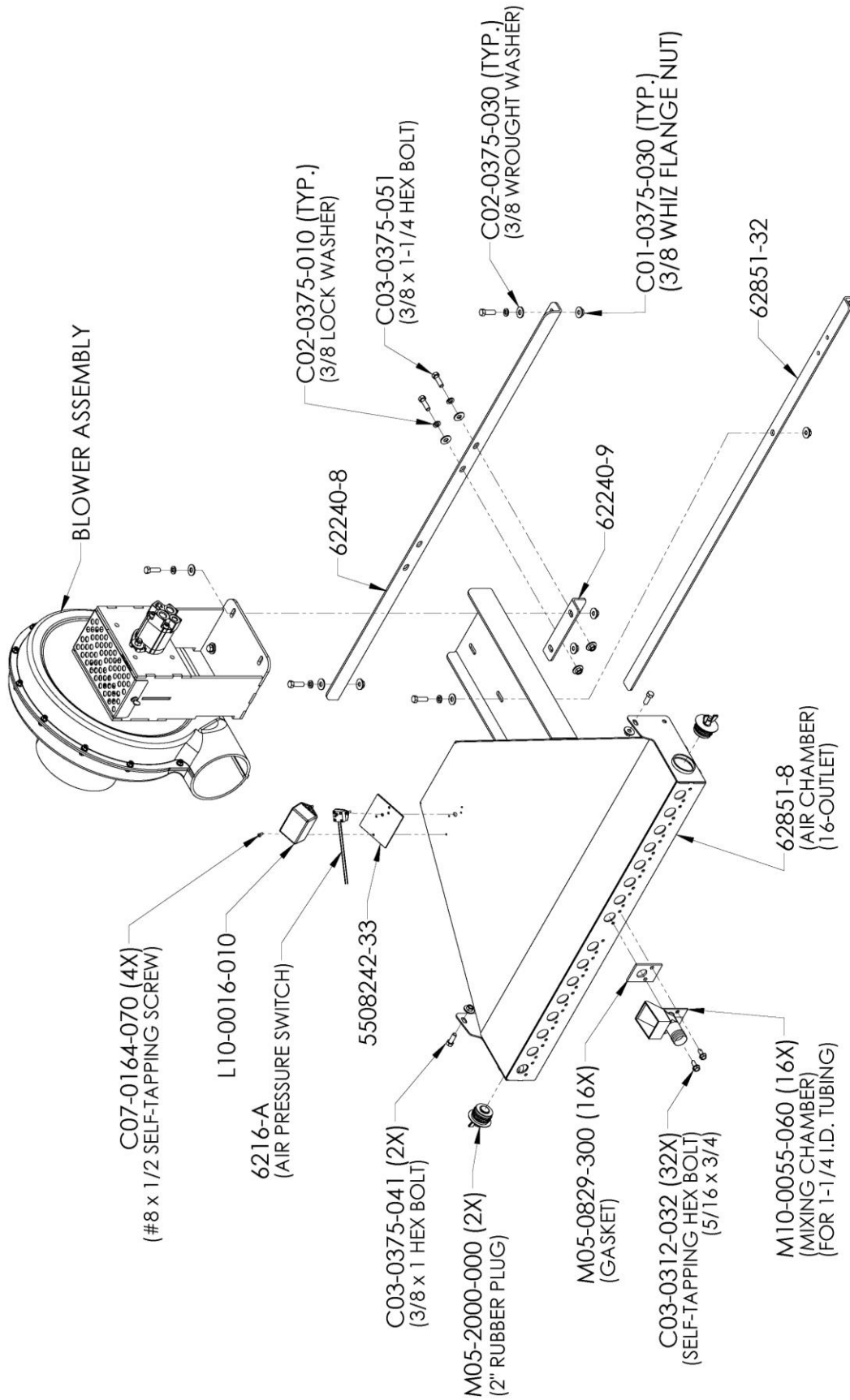

6223-A8

Hydraulic Blower Assembly (62167-P8LH)

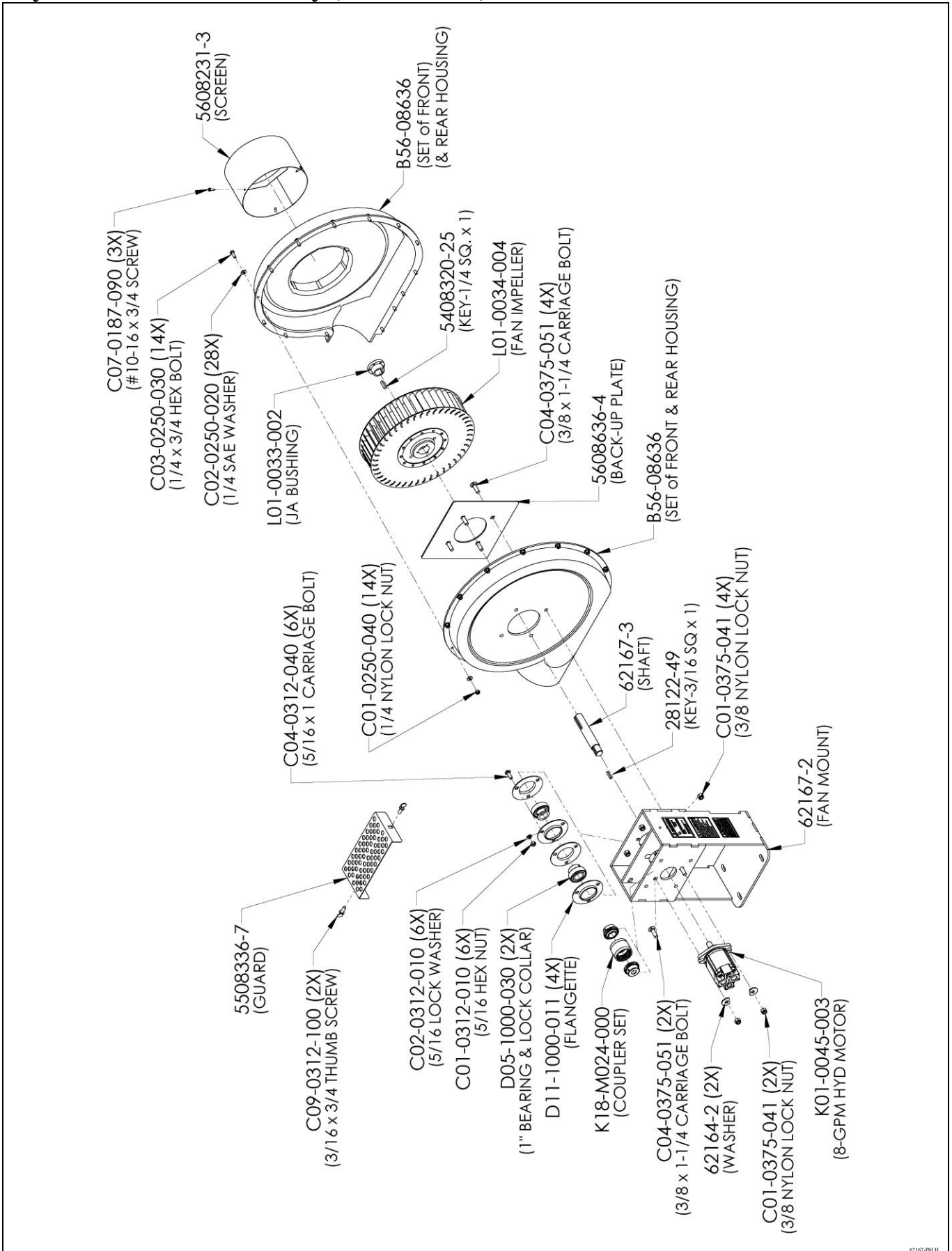

Hydraulic Hose Connections (For Gandy Plastic Housing Fan)

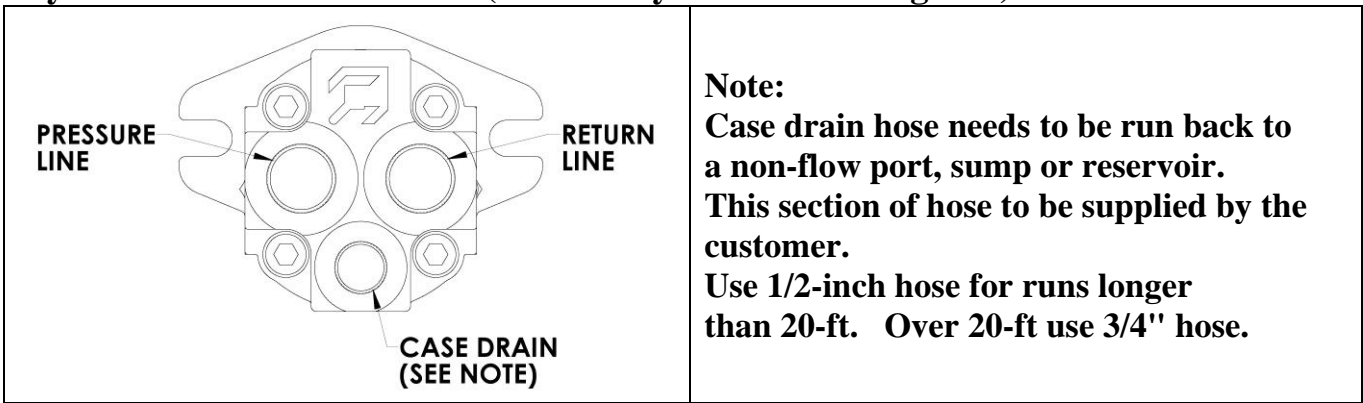

Note:
 Case drain hose needs to be run back to a non-flow port, sump or reservoir.
 This section of hose to be supplied by the customer.
 Use 1/2-inch hose for runs longer than 20-ft. Over 20-ft use 3/4" hose.

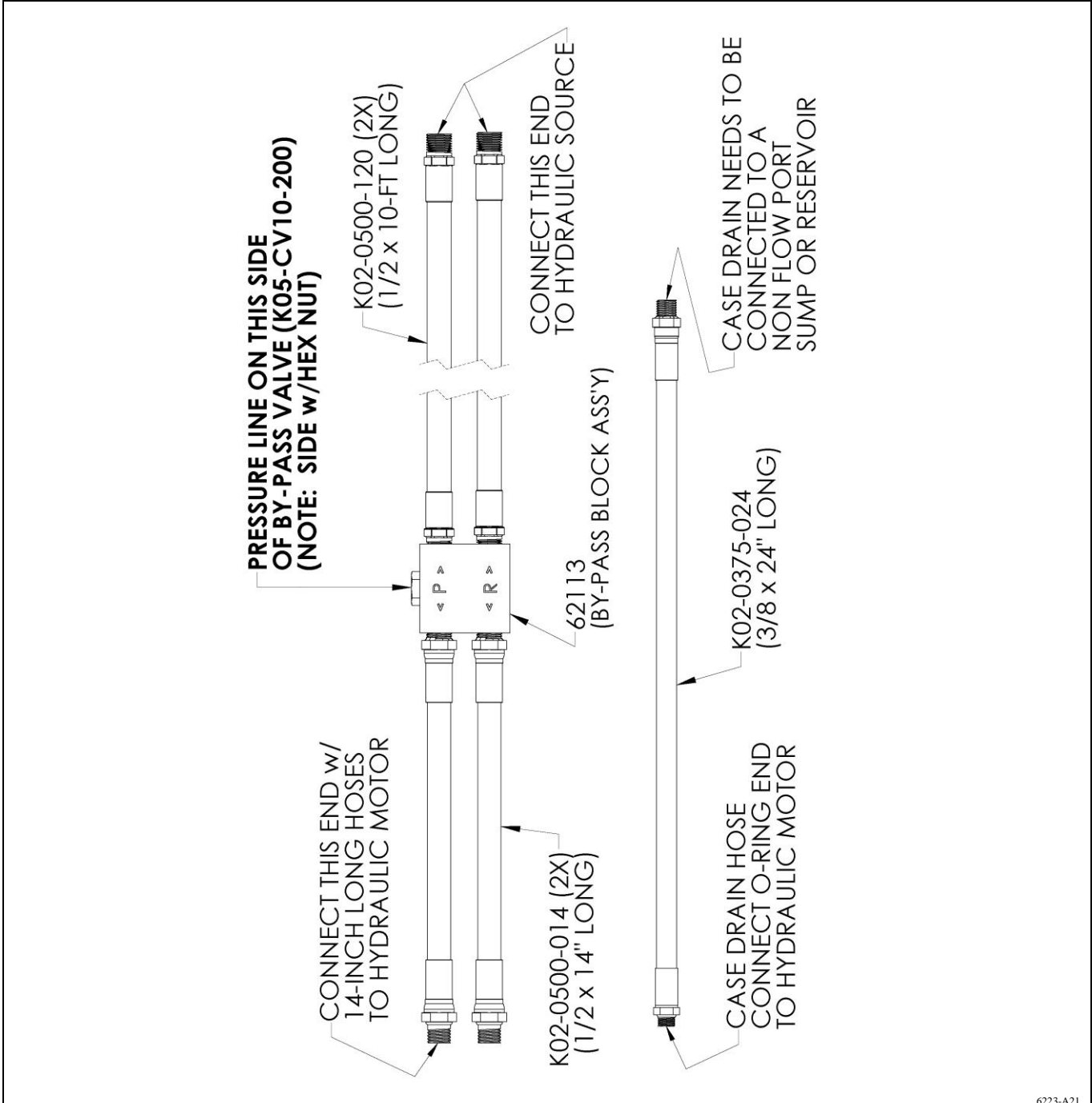

6223-A21

Shaft Sensor

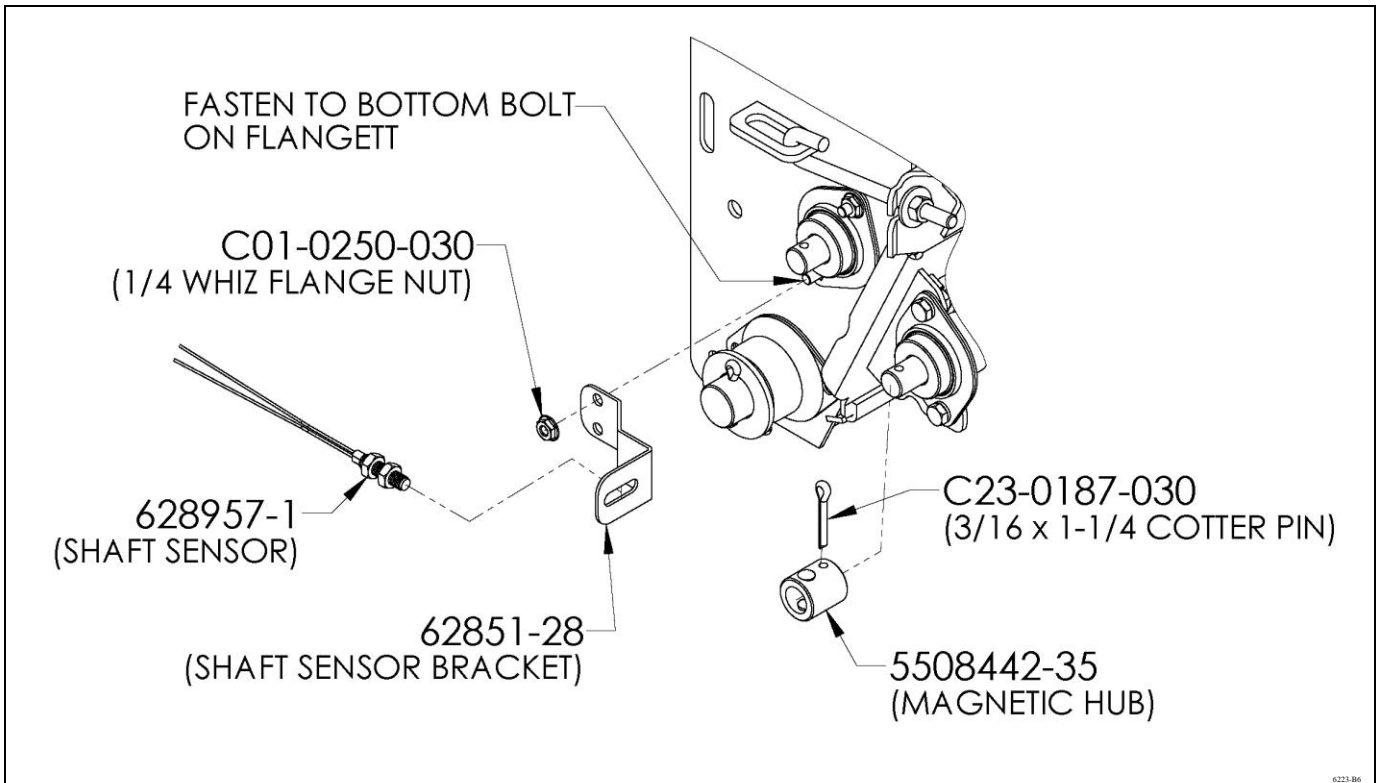

Zero-Max Decal Locations (on Zero-Max)

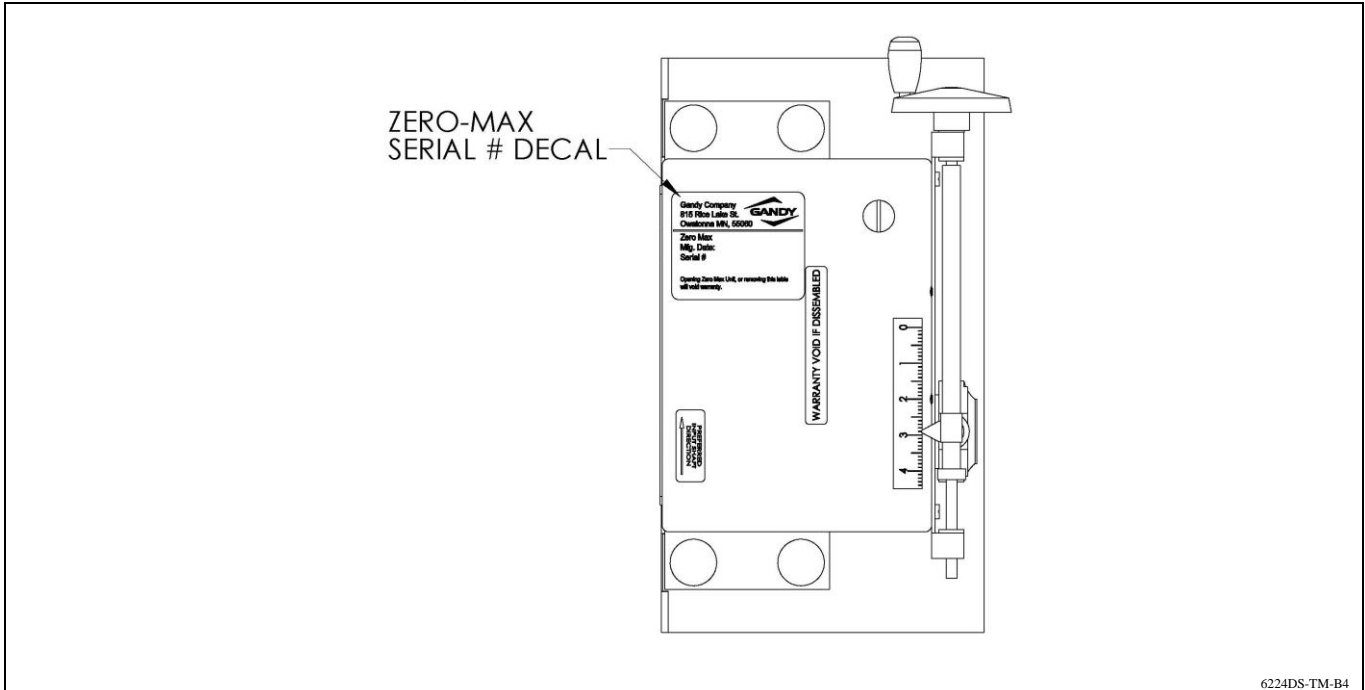

Decal Location (Zero-Max Side)

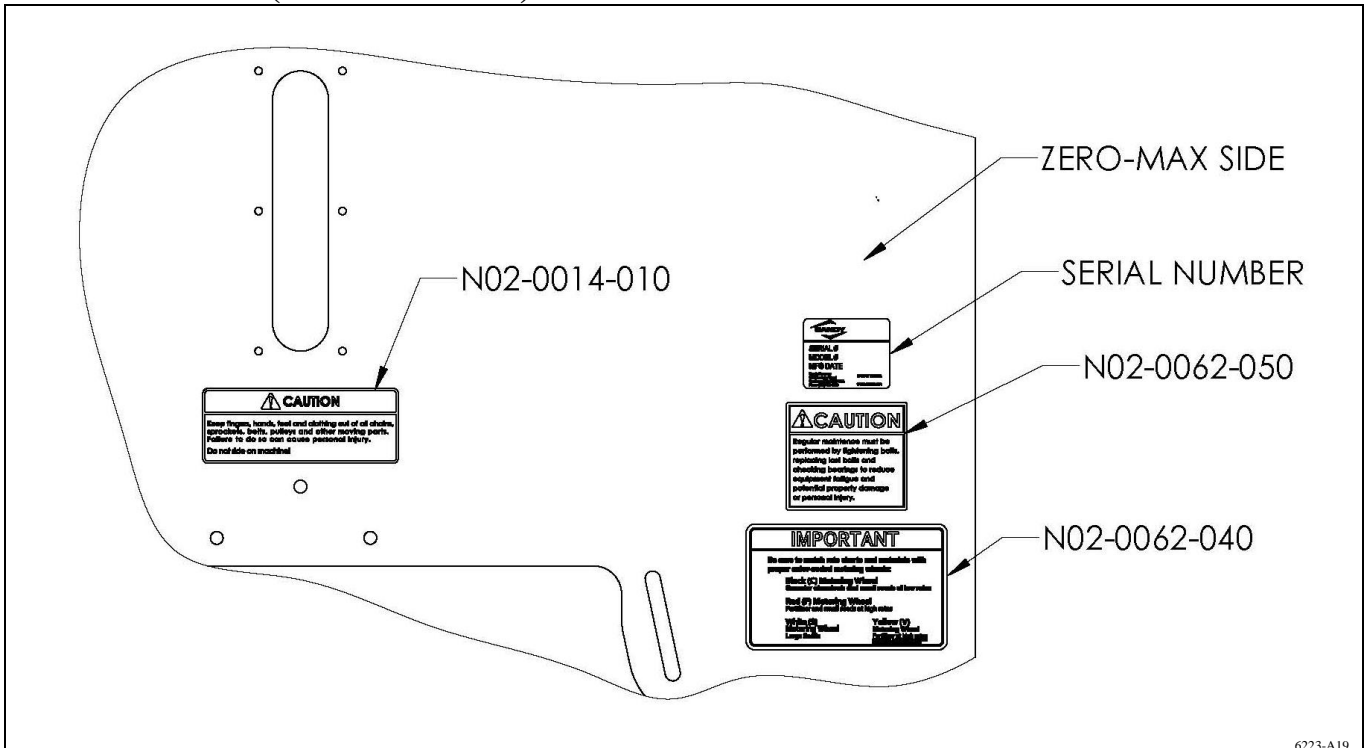

Decal Location (Opposite Side of Zero-Max)

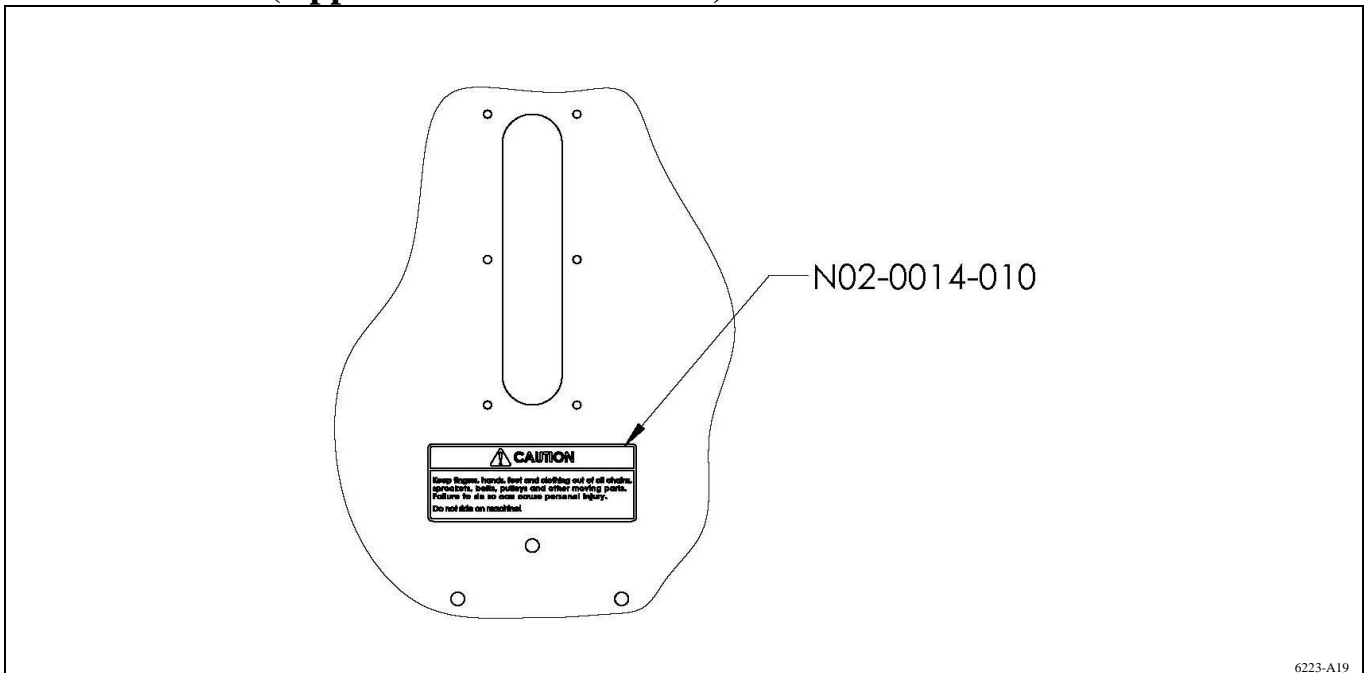

Clean-Out Decal Location

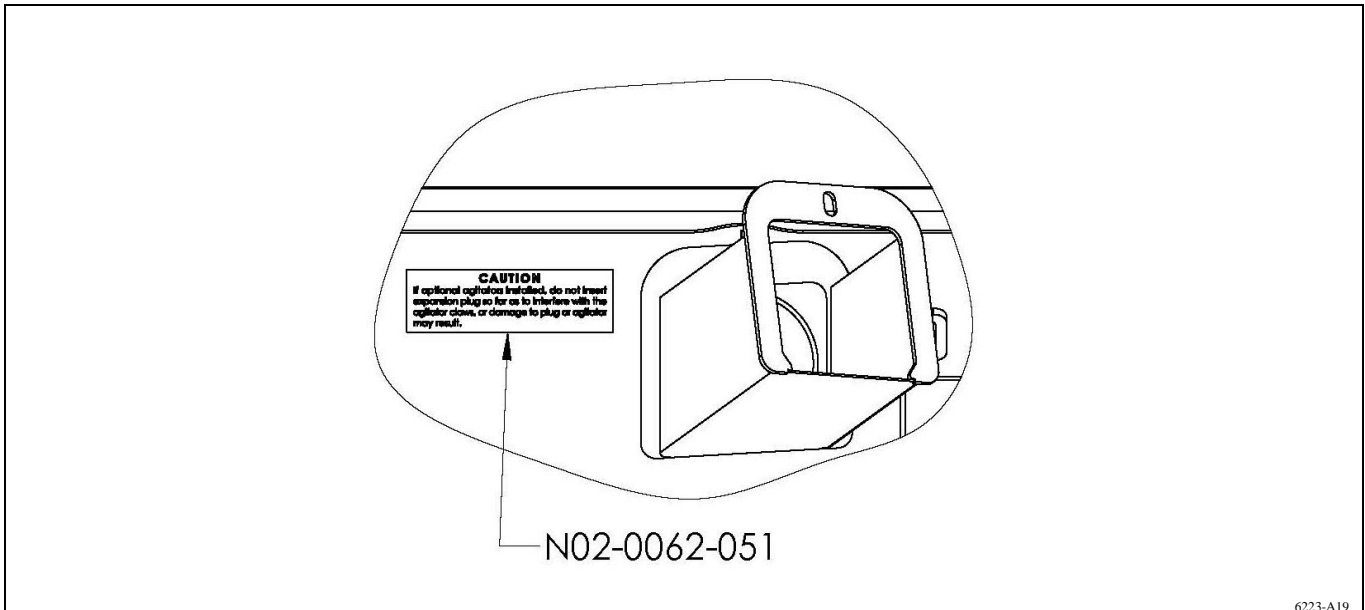

Front & Rear & End Decals

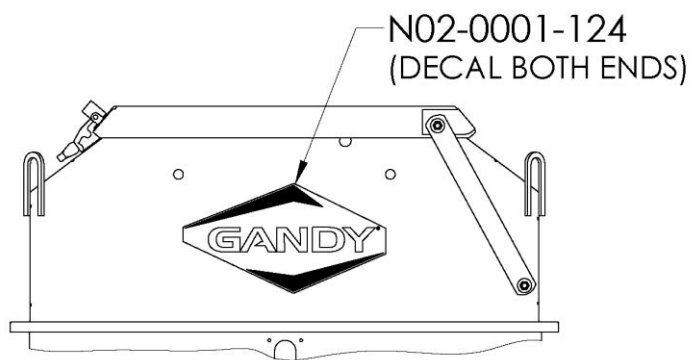
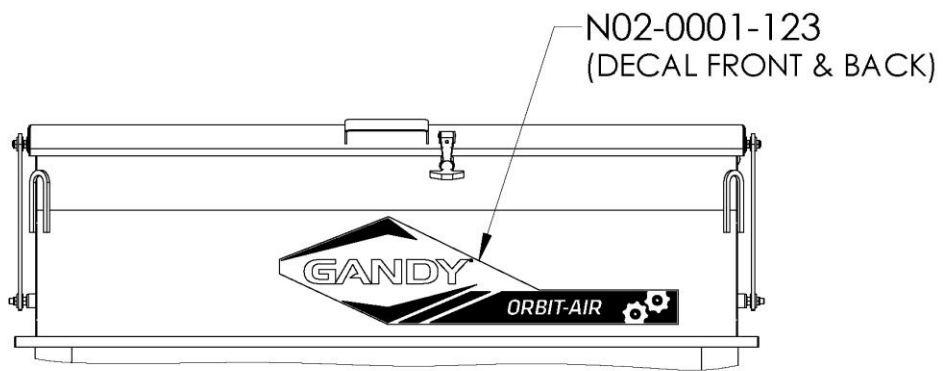

6223-A19

Wiring Connections:

Mount Console in convenient location in tractor cab and connect wires as shown.

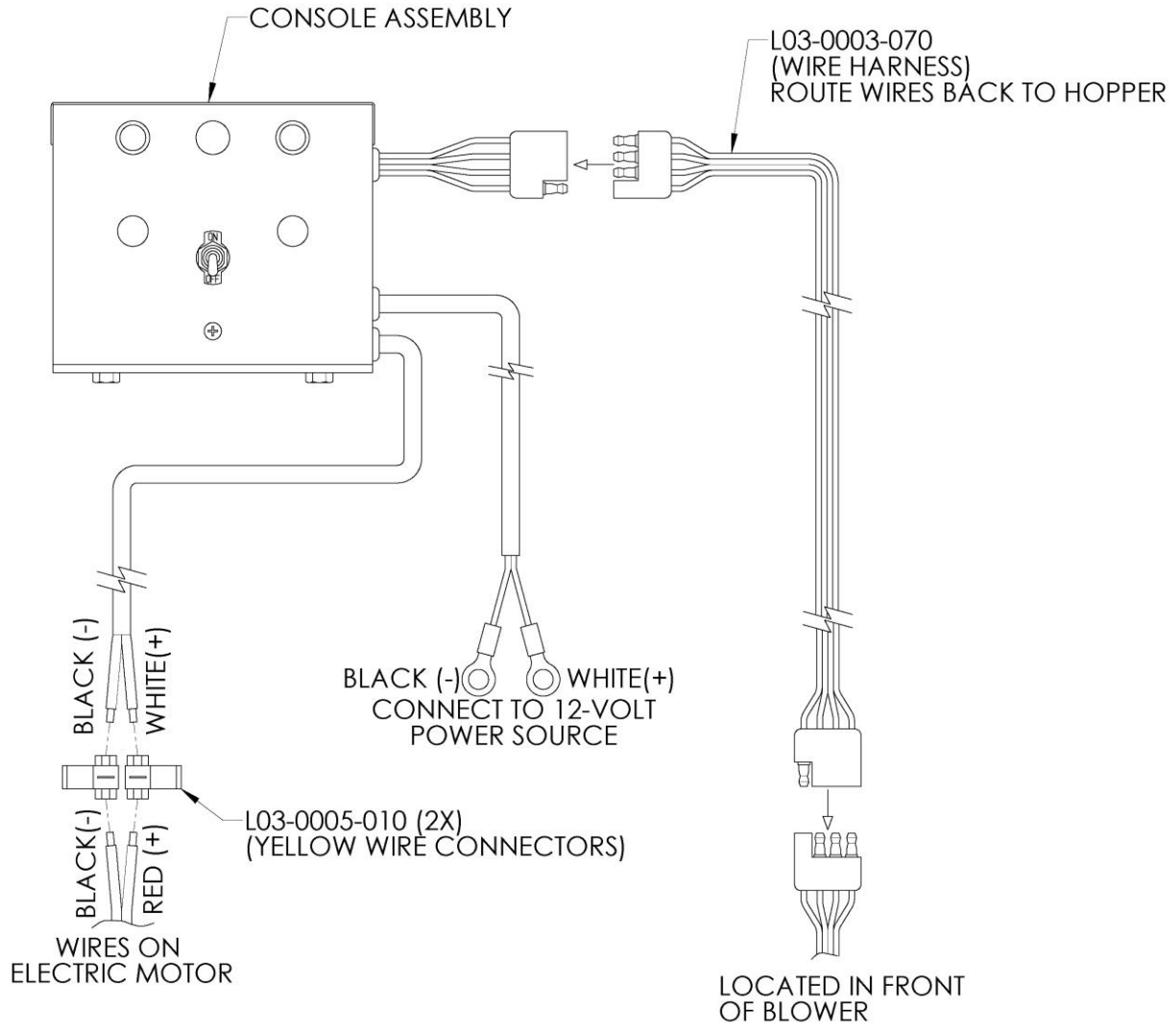

6223-B7

Console Assembly

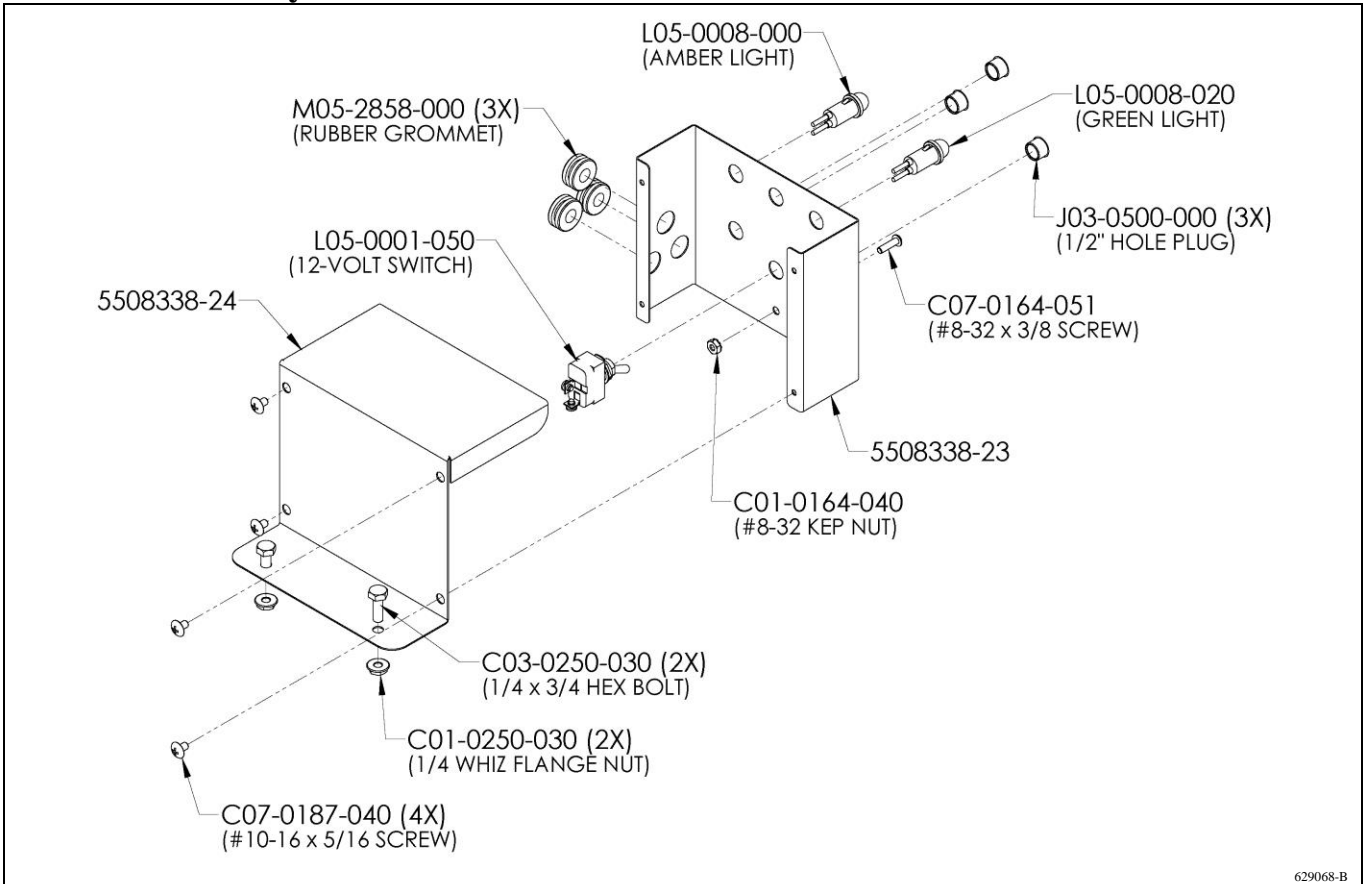

Console Wiring Diagram

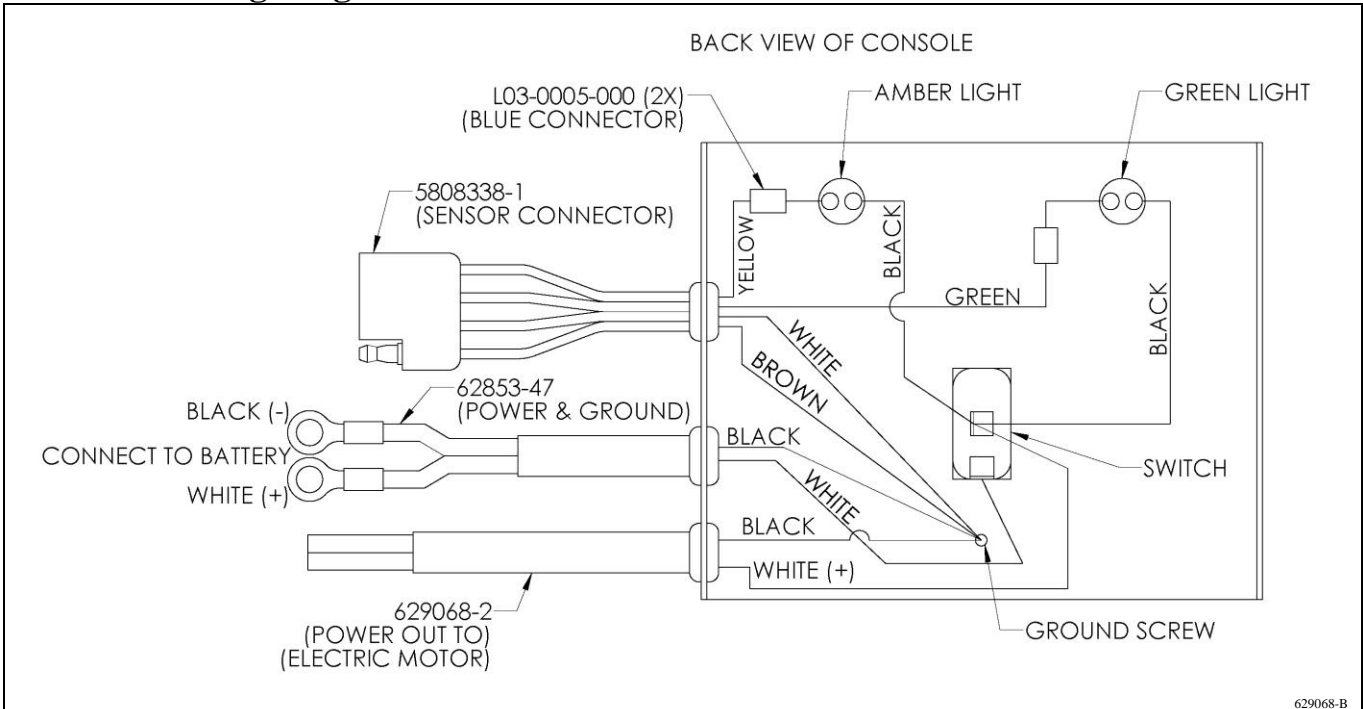

Air Chamber Blank Plates:

Blank Plate (550829-4) is used to block off unused air chamber openings when not needed.

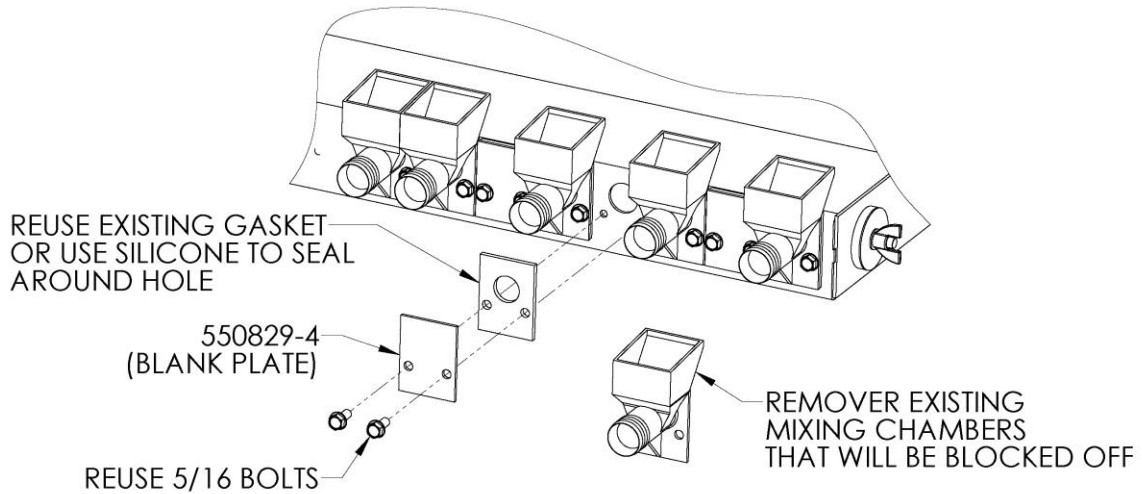

6223-A23

Metering Door Blank Plate:

Blank Plate (62852-20) is used to block off unused metering door openings when not needed.

To remove shaft; First remove sensor hub from shaft, then unbolt bearing flange by sprocket on metering shaft and pull shaft out. Reassembly by reversing instructions.

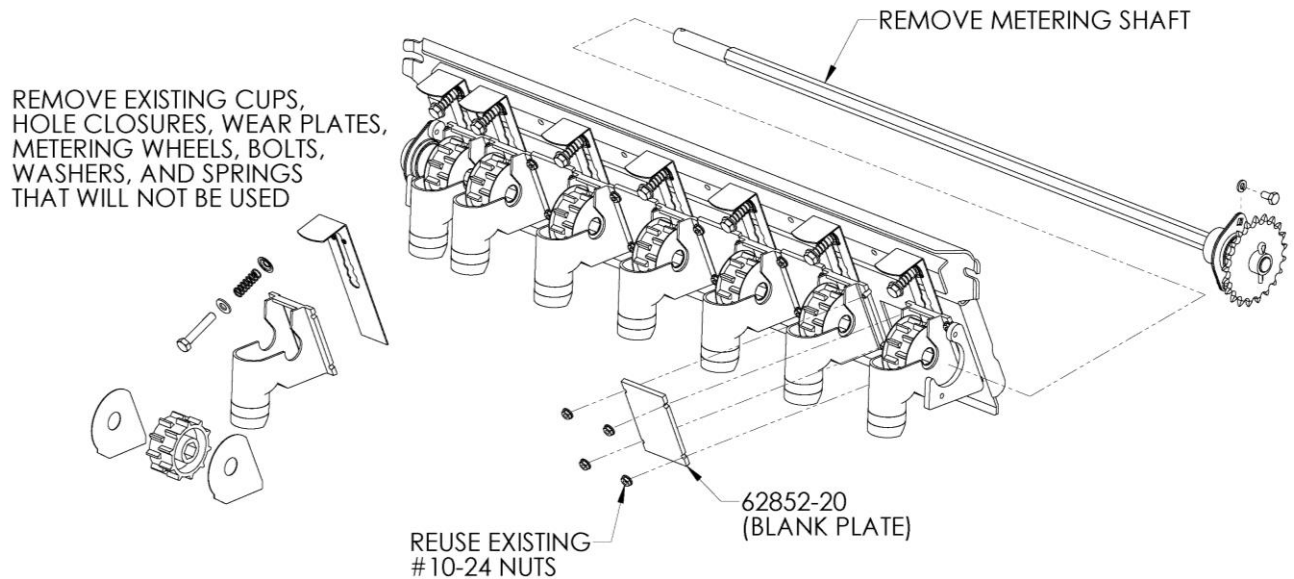

6223-A24

Manual Holder Bracket

Mount manual holder to corner of hopper or convergent location on implement.
Store Operator's manual, Packing List & Rate Chart of convergent access.

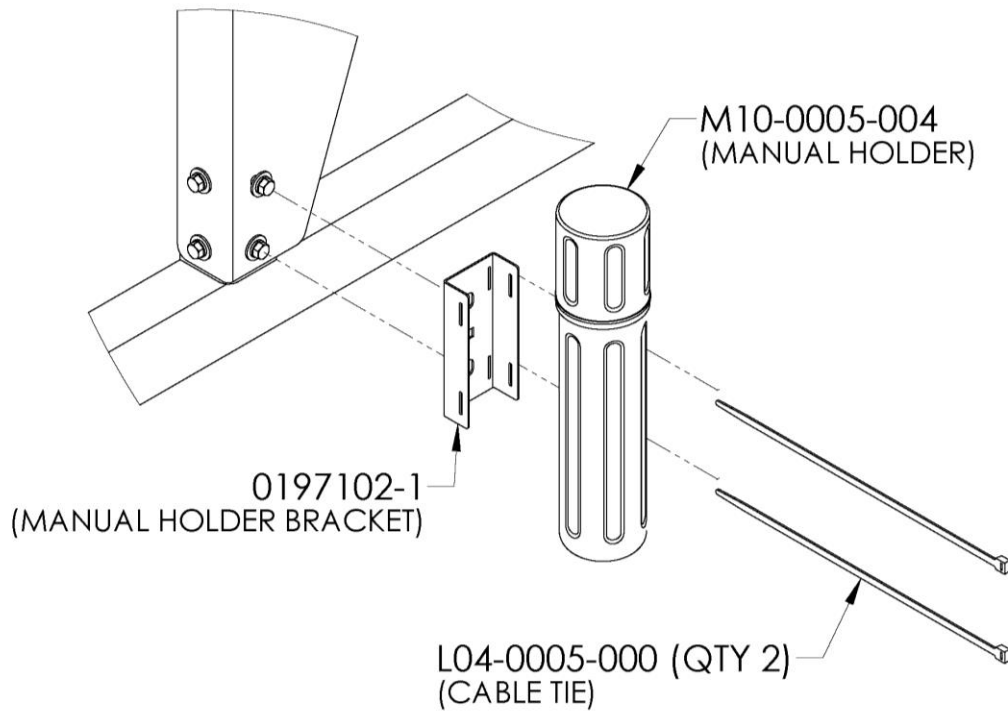

HOLDER-1

(6231DS16F)
December 17, 2020
Revised From (5/8/18)
Printed in the USA