



Illustrated Parts and Packing List & Instructions

815 Rice Lake Street, Owatonna, MN 55060

Phone: 800-443-2476 / 507-451-5430

www.gandy.net / Email: sales@gandy.net

6631GN24C

Orbit-Air Applicator

Implement Mounted Hopper

Hydraulic Raven Monitor Controlled

31 Cu. Ft. (.88m³), 24.8 Bushel, 1395-Lb Chemical Capacity

24 (1-1/4") Chemical (C) Black Wheels

For Use w/ 1-inch I.D. Tubing

Split Metering Shaft, Two Clutches

(All Parts & Hardware in Place Unless Otherwise Specified)

- 1..... S02-0001-034Shipping Crate (23/31 CF Hopper)
Use: 4 Hex Bolt (3/8 x 2-3/4) (C03-0375-111)
8 Wrought Washer (3/8) (C02-0375-030)
4 Whiz Flange Nut (3/8) (C01-0375-030)
- 1..... 62240-1BHopper, 23/31 CF (Painted Black)
Use: 2 Sight Window (610851/26)
4 Rail (610851/27)
12 Pop Rivet (3/16 x 3/8) (C19-0187-030)
1 Decal, Important, Metering Wheel (N02-0062-040)
2 Decal, Caution (N02-0014-010)
1 Decal, Caution Black on Yellow (N02-0062-050)
1 Decal, Caution Plug (N02-0062-051)
- 1..... 62241-1_____.....Roof 31 CF
Use: 2 Carriage Bolt (3/8 x 1-1/2) (C04-0375-061)
2 Wrought Washer (3/8) (C02-0375-030)
2 Whiz Flange Nut (3/8) (C01-0375-030)
20 Carriage Bolt (5/16 x 3/4) (C04-0312-031)
20 Whiz Flange Nut (5/16) (C01-0312-030)
2 Decal, Orbit-Air Small (N02-0001-123)
- 2..... 62240-4.....Bushing Mount (For Out Side Hinge)
Use: 2 Carriage Bolt (3/8 x 2) (C04-0375-080)
2 Whiz Flange Nut (3/8) (C01-0375-030)
- 2..... 62200-22.....Screen Support Bracket
Use: 4 Carriage Bolt (5/16 x 3/4) (C04-0312-031)
4 Whiz Flange Nut (5/16) (C01-0312-030)
- 1..... 62240-3_____.....Cover (For 23/31 CF Hopper)
Use: 2 Carriage Bolt (3/8 x 1-1/4) (C04-0375-051)
2 Wrought Washer (3/8) (C02-0375-030)
2 Jam Lock Nut (3/8) (C01-0375-062)

- 1..... M05-0000-004.....Rubber Latch w/ Keeper
Use: 4 Pop Rivet (C19-0187-000)
- 2..... 62852-3.....Inner Hinge
Use: 2 Hex Bolt (3/8 x 1) (C03-0375-041)
4 Jam Nut, Nylon Lock (3/8) (C01-0375-062)
8 Wrought Washer (3/8) (C02-0375-030)
- 2..... 62852-4.....Outer Hinge
Use: 8 Wrought Washers (3/8) (C02-0375-030)
4 Jam Nut, Nylon Lock (3/8) (C01-0375-062)
- 2..... 629069-1.....Mounting Base w/Holes
Use: 16 Hex Bolt (3/8 x 1-1/4) (C03-0375-051)
16 Wrought Washer (3/8) (C02-0375-030)
16 Lock Washer (3/8) (C02-0375-010)
16 Whiz Flange Nut (3/8) (C01-0375-030)
- 2..... 629066-8.....Shaft, Gear & Driven Sprocket (22-5/8 x 5/8 Round)
- 3..... 63861-7.....Bearing, Plastic (Black) (5/8 Bore)
- 6..... 09074690-4.....Flangette, Bearing (For 63861-7 Bearing)
Use: 6 Carriage Bolt (1/4 x 5/8) (C04-0250-020)
6 Whiz Flange Nut (1/4) (C01-0250-030)
- 2..... 62851-42.....Chain Sprocket, 21-Tooth (5/8 Bore)
Use: 2 Cotter Pin (3/16 x 1-1/4) (C20-0187-030)
- 2..... 62853-9.....Sprocket, 24-Tooth (5/8 Bore x 1-3/8 Hub)
Use: 2 Cotter Pin (3/16 x 1-1/4) (C20-0187-030)
- 1..... 629066-14.....Shaft (49-11/16 x 1-inch Round)
- 2..... D05-1000-010Bearing (For 1-inch Shaft)
Use: 4 Hex Bolt (5/16 x 3/4) (C03-0312-030)
4 Lock Washer (5/16) (C02-0312-010)
4 Hex Nut (5/16) (C01-0312-010)
- 2..... 628720-7.....Bushing (1-1/4 O.D. x 1-1/8 Long)
- 2..... 62240-13.....Bracket, Clutch Mount (For 23/31 CF)
Use: 4 Hex Bolt (5/16 x 3/4) (C03-0312-030)
4 Lock Washer (5/16) (C02-0312-010)
4 Whiz Flange Nut (5/16) (C01-0312-030)
- 2..... 62853-10.....Chain Sprocket 32-Tooth (One Bolted To Each Clutch)
Use: 8 Hex Bolt (1/4 x 3/4) (C03-0250-030)
8 Whiz Flange Nut (1/4) (C01-0250-030)
- 1..... 62853-12.....Electric Clutch w/ 35-Tooth Sprocket
Use: 1 Cable-Tie (3/16 x 4) (L04-0001-000)
1 Hex Bolt (3/8 x 1) (C03-0375-041)
3 Wrought Washer (3/8) (C02-0375-030)
1 Lock Washer (3/8) (C02-0375-010)
1 Whiz Flange Nut (3/8) (C01-0375-030)
- 1..... L05-0010-001Electric Clutch
Use: 1 Cable-Tie (3/16 x 4) (L04-0001-000)
1 Hex Bolt (3/8 x 1) (C03-0375-041)
3 Wrought Washer (3/8) (C02-0375-030)
1 Lock Washer (3/8) (C02-0375-010)
1 Whiz Flange Nut (3/8) (C01-0375-030)
- 2..... 62854-29.....Washer, Electric Clutch
Use: 2 Hex Bolt (5/16 x 3/4) (C03-0312-030)
2 Lock Washer (5/16) (C02-0312-010)

- 1 62851-43 Air Chamber 24-Outlet (23/31 CF)
 Use: 3 Hex Bolt (3/8 x 1) (C03-0375-041)
 1 Wrought Washer (3/8) (C02-0375-030)
 1 Lock Washer (3/8) (C02-0375-010)
 3 Whiz Flange Nut (3/8) (C01-0375-030)
- 1 641-3 Air Pressure Switch Assembly:
 Use: 2 Pan Head TC Screw (#8 x 1/2) (C07-0164-070)
- 1 5508242-33 Gasket, Potting Box
- 1 L10-0016-010 Potting Box (Air Pressure Switch Plastic Cover)
 Use: 2 Pan Head TC Screw (#8 x 1/2) (C07-0164-070)
- 4 M05-0187-000 Gasket, Mixing Chambers
- 24 M10-0055-001 Mixing Chamber, Narrow (For 1-inch I.D. Tubing)
 Use: 28 Hex Head Self-Tap Bolt (5/16 x 3/4) (C03-0312-032)
- 2 M05-2000-000 Rubber Plug, 2-inch (For air Chamber)
- 1 62851-32 Angle Support, For Air Chamber & Blower
- 1 628720-18 Clean-Out Chute, 4-inch
 Use: 1 Wing Nut (5/16) (C01-0312-020)
 1 Wrought Washer (5/16) (C02-0312-030)
- 1 M05-3000-000 Rubber Plug, 3-inch (For Hopper)
- 1 62240-10 Angle Clamp, Tubes (For 23/31 CF)
 Use: 4 Foam Clamp Strip 9-1/2 Long (62851-16)
 5 Hex Bolt (5/16 x 2-1/4) (C03-0312-091)
 5 Lock Nut, Nylon (5/16) (C01-0312-040)
- 1 5608226 Bar Clamp, Plastic Tubing (For 23/31 CF)
 Use: 4 Foam Clamp Strip 9-1/2 Long (62851-16)
- 2 62852-16 Mounting Bracket, Platform (23/31 CF)
 Use: 4 Carriage Bolt (5/16 x 3/4) (C04-0312-031)
 4 Whiz Flange Nut (5/16) (C01-0312-030)
- 1 62851-10 Platform (For 23/31 CF)
 Use: 3 Grip Tape (3 x 48-1/2 Long) (62851-15)
- 1 62851-37 Angle Support (For 23/31 CF Platform)
 Use: 4 Carriage Bolt (5/16 x 3/4) (C04-0312-031)
 4 Whiz Flange Nut (5/16) (C01-0312-030)
- 1 62851-67 Clear Windshield (For 23/31 CF)
 Use: 6 Hex Bolt (1/4 x 5/8) (C03-0250-020)
 6 Wrought Washer (5/16) (C02-0312-030)
 6 Whiz Flange Nut (1/4) (C01-0250-030)
- 4 62851-5 Screen (For 23/31 CF)
- 1 62240-8 Bracket Long Fan Support
 Use: 2 Hex Bolt (3/8 x 1-1/4) (C03-0375-051)
 2 Wrought Washer (3/8) (C02-0375-030)
 2 Lock Washer (3/8) (C02-0375-010)
 2 Whiz Flange Nut (3/8) (C01-0375-030)
- 1 62240-9 Bracket Short Fan Support
 Use: 2 Hex Bolt (3/8 x 1-1/4) (C03-0375-051)
 2 Wrought Washer (3/8) (C02-0375-030)
 2 Lock Washer (3/8) (C02-0375-010)
 2 Whiz Flange Nut (3/8) (C01-0375-030)

Sensors & Wire Extensions

2.....	5508442-35.....	Magnetic Hub, 5/8 Bore (Installed on Metering Door Shaft) Use: 2 Spring Pin (3/16 x 1) (C23-0187-140)
2.....	661-14.....	Sensor Wire Extension (24-inch Long)
2.....	661-16.....	Shaft Sensor
2.....	62240-11.....	Bracket Sensor Use: 2 Hex Bolt (1/4 x 1/2) (C03-0250-020) 2 Lock Washers (1/4) (C02-0250-010) 2 Whiz Flange Nut (1/4) (C01-0250-030)
2.....	62240-12.....	Mount Sensor Use: 2 Carriage Bolt (1/4 x 5/8) (C04-0250-020) 2 Whiz Flange Nut (1/4) (C01-0250-030)
2.....	641-4.....	Wire Assembly, Clutch Extension (30-inch Long)

Mount Bracket & Parts for Hydraulic Drive Motor

1.....	661-12.....	Motor Mount (For Hydraulic Motor Drive) Use: 2 Hex Bolt (5/8 x 4) (C03-0625-161) 2 SAE Washer (5/8) (C02-0625-020) 2 Lock Washer (5/8) (C02-0625-010) 2 Hex Nut (5/8) (C01-0625-010) 2 Carriage Bolt (3/8 x 1-1/4) (C04-0375-051) 2 Wrought Washer (3/8) (C02-0375-030) 2 Lock Washer (3/8) (C02-0375-010) 2 Hex Nut (3/8) (C01-0375-010)
1.....	F02-0041-054.....	Roller Chain #41 (54-Rollers) (Hyd Motor to Drive Shaft) Use: 1 Connector Link #41 (F02-0041-001)

Hydraulic Drive Motor Assembly (6623-A)

1	K01-1022-000	Hydraulic Motor
1	09073678-4	Plate, Motor Mount
		Use: 2 Hex Bolts (3/8 x 1) (C03-0375-041)
		2 Lock Washer (3/8) (C02-0375-010)
1	661-2	Sensor Bracket
		Use: 2 Hex Bolts (3/8 x 1) (C03-0375-041)
		2 Wrought Washer (3/8) (C02-0375-030)
		2 Lock Washer (3/8) (C02-0375-010)
1	661-13	Regulator Block
		Use: 2 Socket Pipe Plug 1/4-18 NPT (C06-0250-300)
		4 Socket Head Cap Screw (5/16 x 2) (C06-0312-130)
1	L08-SV10-230	Solenoid Valve
		Use: 2 Terminal, 14-16ga, Male #634005 (L03-0009-090)
1	661-11	Sensor, Sprocket
		Use: 1 Carriage Bolt (1/4 x 5/8) (C04-0250-020)
		1 Whiz Flange Nut (1/4) (C01-0250-030)
1	661-7	Sprocket, 13-Tooth (1-inch Bore w/ 1/4 Keyway)
1	661-6	Bushing (1-1/8 O.D. x 1/2 Long)
1	661-4	Sprocket, 20-Tooth (7/8 Bore)
		Use: 2 Spring Pin (1/8 x 1-3/4) (C23-0125-200)
1	661-5	Collar, Hydraulic Speed Comp Drive
		Use: 1 Hex Bolt (1/4 x 1-1/4) (C03-0250-051)
		1 Lock Washer (1/4) (C02-0250-010)

Hydraulic Valve Assembly (6623-B)

1	L07-0063-195	Hydraulic Control Valve, 16 GPM
		Use: 3 Apt SAE 10, Male 1/2 NPT, Female Swivel (K04-0500-010)
1	661-15	Bracket, Motor Control (For 10 & 23/31 Cu Ft Hopper)
		Use: 2 Hex Bolt (5/16 x 3/4) (C03-0312-030)
		2 Lock Washer (5/16) (C02-0312-010)
		2 Whiz Flange Nut (5/16) (C01-0312-030)
2	K02-0500-120	Hydraulic Hose, 1/2 x 120"
3	K02-0500-014	Hydraulic Hose, 1/2 x 14" w/ O-Ring Fitting On One End
1	K02-0500-012	Hydraulic Hose, 1/2 x 12" w/ Fitting
1	K02-0500-021	Hydraulic Hose, 1/2 x 21"
1	K07-0500-010	Steel Pipe Tee (1/2)
1	K09-0500-000	90° High Pressure Sp Elbow (1/2)
1	K11-0500-028	Steel Pipe Nipple (1/2 x 1-13/16)
1	62113	Hydraulic By-Pass Block Assembly w/Check Valve
1	K05-CV10-200	Check Valve
1	6296-1	Hydraulic By-Pass Block

Metering Door Assembly

1	62851-B	Metering Door Assembly, 24 (1-1/4) Chemical Wheels:
1	62851-45.....	Mounting Plate, Metering Cup, 24 Openings
		Use: 2 J-Bolt (5/16) (C16-0312-020) (Not Part of Assembly)
		2 Wrought Washer (5/16) (C02-0312-030) (Not Part of Assembly)
		2 Wing Nut (5/16) (C01-0312-020) (Not Part of Assembly)
4 Ft.	M05-0125-050.....	Rubber Strip w/ Adhesive (1/8 x 1/2)
4	62851-73.....	Gang Cup, Stainless
		Use: 12 Whiz Flange Nut (3/16) (C01-0187-030)
24	62851-77.....	Hole Closures, Gang Cup
		Use: 24 Comp Spring (E00-0420-012)
		24 Extruded Washer (628720-20)
		24 SAE Washer (5/16) (C02-0312-020)
		24 Hex Bolt (5/16 x 1-3/4 Stainless) (C03-0312-071)
24	62851-75.....	Metering Wheel Black
2	629066-7.....	Shaft (21-7/16 x 5/8 Hex)
3	63861-7.....	Bearing, Plastic (Black) (5/8 Bore)
6	09074690-4.....	Flangette, Bearing (For 63861-7 Bearing)
		Use: 6 Hex Bolt (1/4 x 1/2 Stainless) (C03-0250-013)
		6 Lock Washer (1/4 Stainless) (C02-0250-012)
2	62851-41.....	Sprocket 21-Tooth, (5/8 Bore)
		Use: 2 Cotter Pin (3/16 x 1-1/4) (C20-0187-030)

1..... K02-0375-024Hydraulic Hose, 3/8 x 24" (Case Drain)

Hydraulic Blower Assembly

- 1..... 62167-P8LHBlower Assembly, 8 GPM Hydraulic Motor, w/out Hoses**
- 1 B56-08636Front & Back Blower Housing (Plastic)
 - Use: 14 Hex Bolt (1/4 x 3/4) (C03-0250-030)
 - 28 SAE Washer (1/4) (C02-0250-020)
 - 14 Lock Nut, Nylon (1/4) (C01-0250-040)
 - 1 5608636-4.....Back-Up Plate
 - Use: 4 Carriage Bolt (3/8 x 1-1/4) (C04-0375-051)
 - 4 Lock Nut, Nylon (3/8) (C01-0375-041)
 - 1 62167-2.....Mount, Blower (Plastic w/Coupler)
 - Use: 1 Decal, Warning Rotating Parts (N02-0055-010)
 - 1 Decal, Important Hydraulic Motor (N02-0062-043)
 - 1 Decal, Black on Yellow (N02-0062-050)
 - 1 L01-0034-004Fan, Impeller
 - Use: 1 Bushing (1-inch JA Bore) (L01-0033-002)
 - 1 Key, Fan Shaft (1/4 x 1) (5408320-25)
 - 1 62167-3.....Shaft (6 Inch Long)
 - 1 28122-49.....Key, for Coupler (3/16 sq. x 1)
 - 1 K18-M024-000.....Coupler (9/16 x 7/8)
 - Replacement Parts(K18-M024-003 Black Plastic Coupler Sleeve) (5508230-5 1/8 x1 Key)
 - (K18-M024-004 Coupler for 9/16 Shaft on Hyd Motor)
 - (K18-M024-005 Coupler for 7/8 Shaft on End of Fan Shaft)
 - 1 K01-0045-003Hydraulic Motor, 8-GPM Casappa
 - Use: 2 Carriage Bolt (3/8 x 1-1/4) (C04-0375-051)
 - 2 Washer, Motor Side, Stainless (62164-2)
 - 2 Lock Nut, Nylon (3/8) (C01-0375-041)
 - 2 D05-1000-030Bearing & Locking Collar (For 1-inch Shaft)
 - 4 D10-1000-011Flangette, Round
 - Use: 6 Carriage Bolt (5/16 x 1) (C04-0312-040)
 - 6 Lock Washer (5/16) (C02-0312-010)
 - 6 Hex Nut (5/16) (C01-0312-010)
 - 1 5608231-3.....Screen, Blower
 - Use: 3 Pan Head Sheet Screw (#10 x 3/4) (C07-0187-090)
 - 1 5508336-7.....Guard, Blower Shaft
 - Use: 2 Thumb Screw (5/16 x 3/4) (C09-0312-100)

Following Parts Are Shipped Inside Hopper:

- 1 0197102-1 Manual Holder Bracket
- 2 L04-0005-000 Cable Tie (5/16 x 15-1/4)
- 1 M10-0005-004 Manual Holder

- 1 L07-0063-484 Wheel Speed Sensor
- 1 L07-0063-829 Console
- 1 L07-0115-456 Console Valve Adapter Cable
- 1 L07-0115-555 Cable, Two Clutch, Two Shafts
- 1 L07-0115-651 Grain Flow, 10 Ft, 22 Pin
- 1 L07-0115-652 Grain Flow Cable, 12 Ft, 22 Pin

1.....642-B.....Parts Carton Containing:

- 6 62851-66 Hole Shut Off Gang Cup (Use Only When Hole Is To Be Closed Completely)
- 6 62851-48 Blank Plate, Air Chamber (Narrow)
- 8 550828-3 Bar Clamp
- 8 09071598-5 Stud Bolt (5/8 x 13-1/20)
- 1 642-BH Hardware Bag:**
 - 16 C01-0625-010 Hex Nut (5/8)
 - 16 C02-0625-010 Lock Washer (5/8)

1.....6216-DAir Pressure Gauge Carton:

- 1 K17-P734-001 Air Pressure Gauge 4-inch
- 1 62851-46 Mounting Bracket, Air Pressure Gauge
- 1 62851-47 Clamp Bracket
- 2 K04-0250-375 Adapter Plastic (1/4 MPT x 3/8 HB)
- 4.5 Ft C06-0375-000 Tubing 3/8 I.D. x 1/8 Wall (54-inches Long)
- 1 C03-0312-040 Hex Bolt (5/16 x 1)
- 1 C01-0312-030 Whiz Flange Nut (5/16)

1.....662-CRun Hold Switch Carton Containing:

- 4 C01-0375-030 Whiz Flange Nut (3/8)
- 2 644-2 U-Bolt 3/8" (For 3 x 3 Sq Tube)
- 1 62150-21 Spring Bracket Mount
- 1 Run Hold Switch Assembly:**
 - 1 62150-20 Run Hold Mount
 - Use: 3 Hole Plug (3/8) (J03-0375-000)
 - 1 L05-0001-001 Switch, Snap Action #3XG49-9
 - Use: 2 Slot Rd Hd Mach Screw (#6-32 x 1-1/4) (C08-0138-140)
 - 2 Shake Proof Washer (#6-32) (C02-0138-040)
 - 2 Hex Nut (#6-32) (C01-0138-010)
 - 1 6611-1 Wire Assembly, Run/Hold
 - Use: 1 Strain Relief Bushing (J04-0500-000)
 - 1 C16-0250-010 Eye Bolt (1/4 x 9/16 I.D. x 2-1/2)
 - Use: 2 Hex Nut (1/4) (C01-0250-010)
 - 1 Coupling Nut (1/4) (C01-0250-101)
 - 1 Hex Bolt (1/4 x 2-3/4) (C03-0250-110)
 - 1 Spring (E00-0375-040)
 - 3 Key Ring (5/8) (M11-0001-000)
 - 1 S-Hook (M11-0006-000)
 - 1 Sash Chain #25 (16-inches) (F03-0025-000)
 - 1 Compression Spring (E01-0664-4)
 - 1 Bushing (62150-22)
 - 1 Stop Washer (62150-23)

Cover Hinge Bolt Assembly

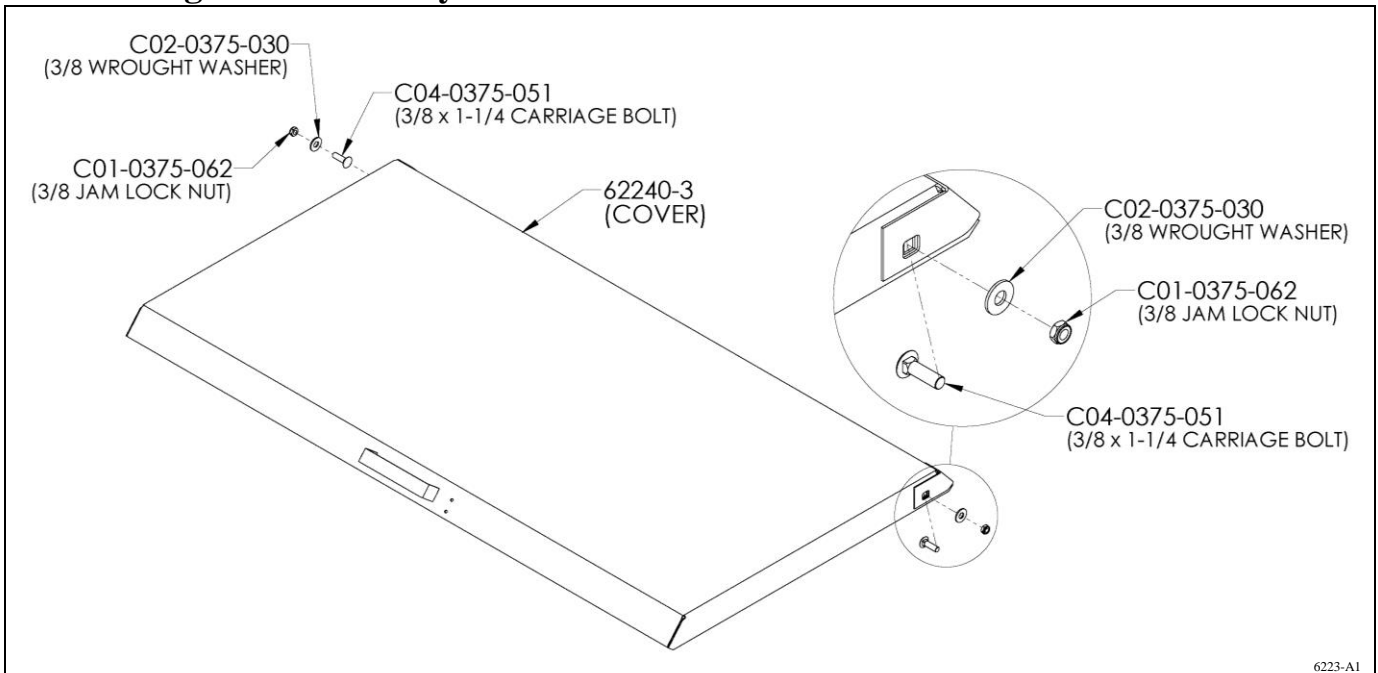

Roof Hinge Bolt Assembly

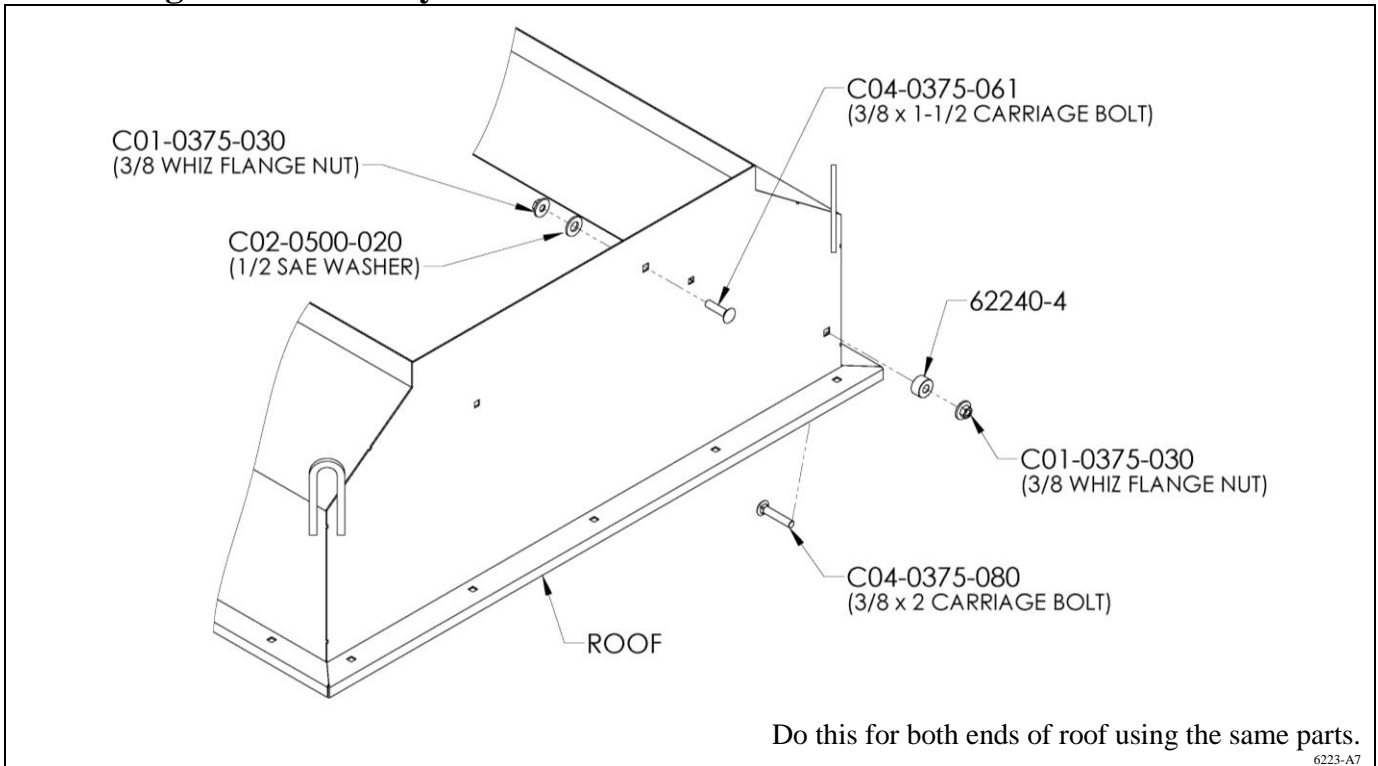

Roof Assembly

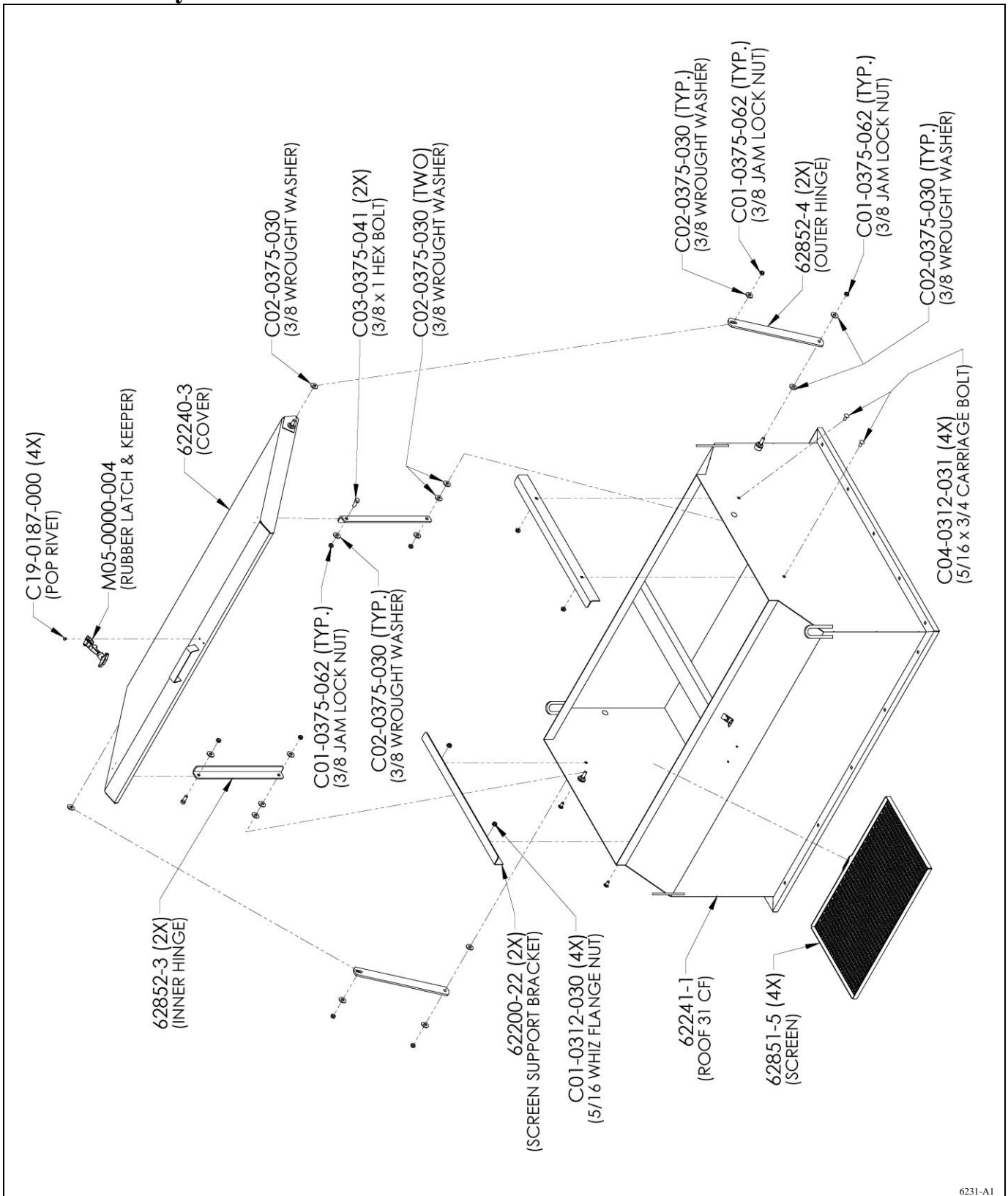

6231-A1

Sight Window Assembly

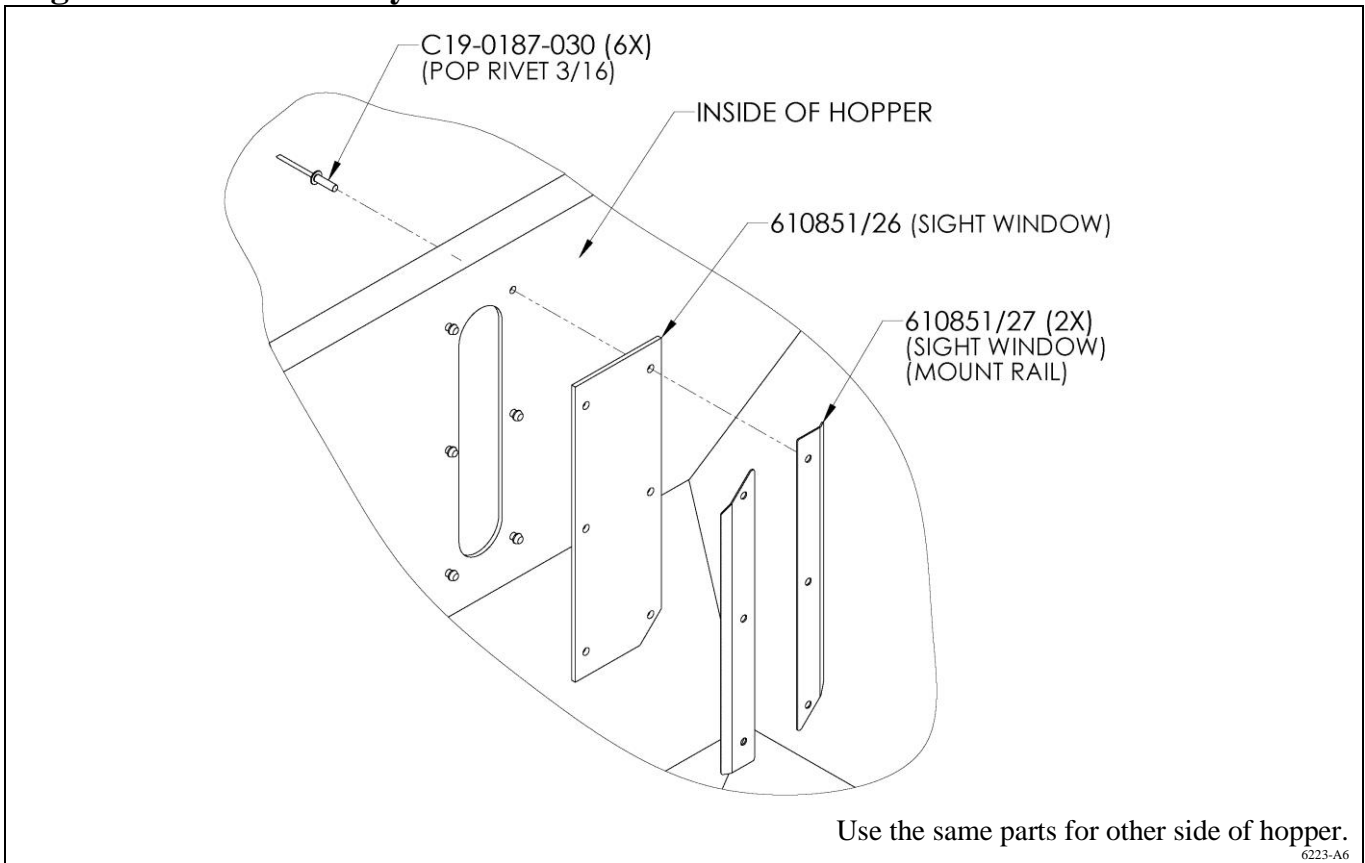

Roof to Hopper Assembly

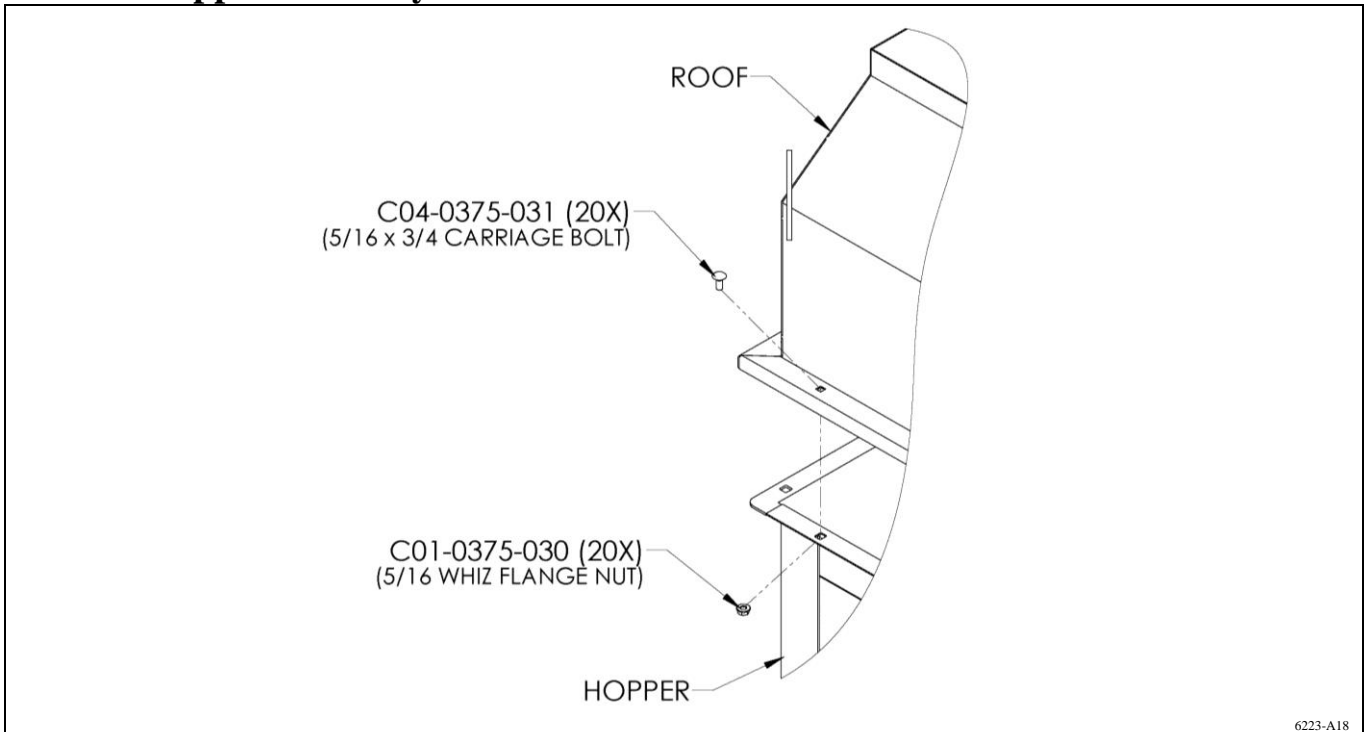

Hopper Assembly

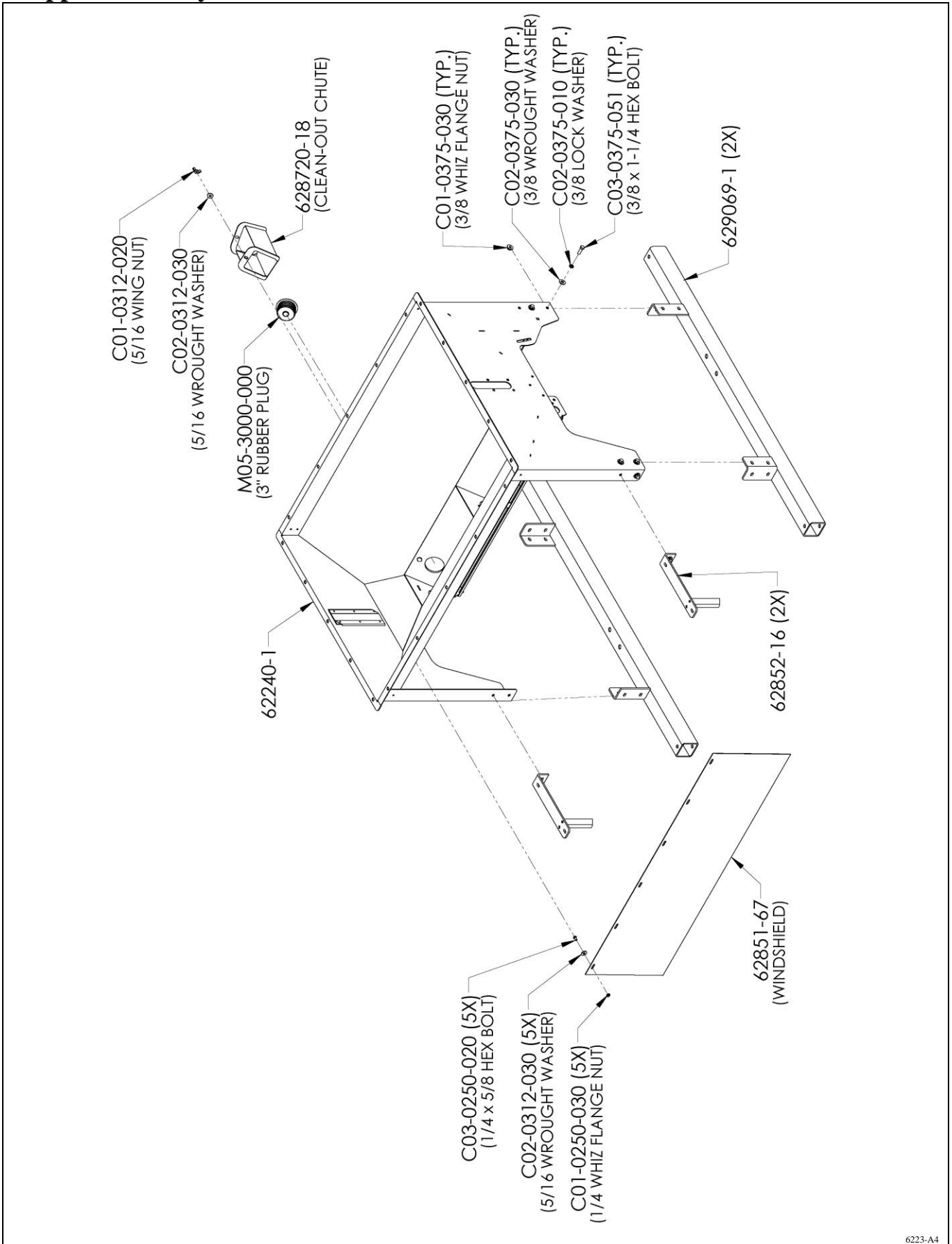

6223-A4

Hopper Assembly

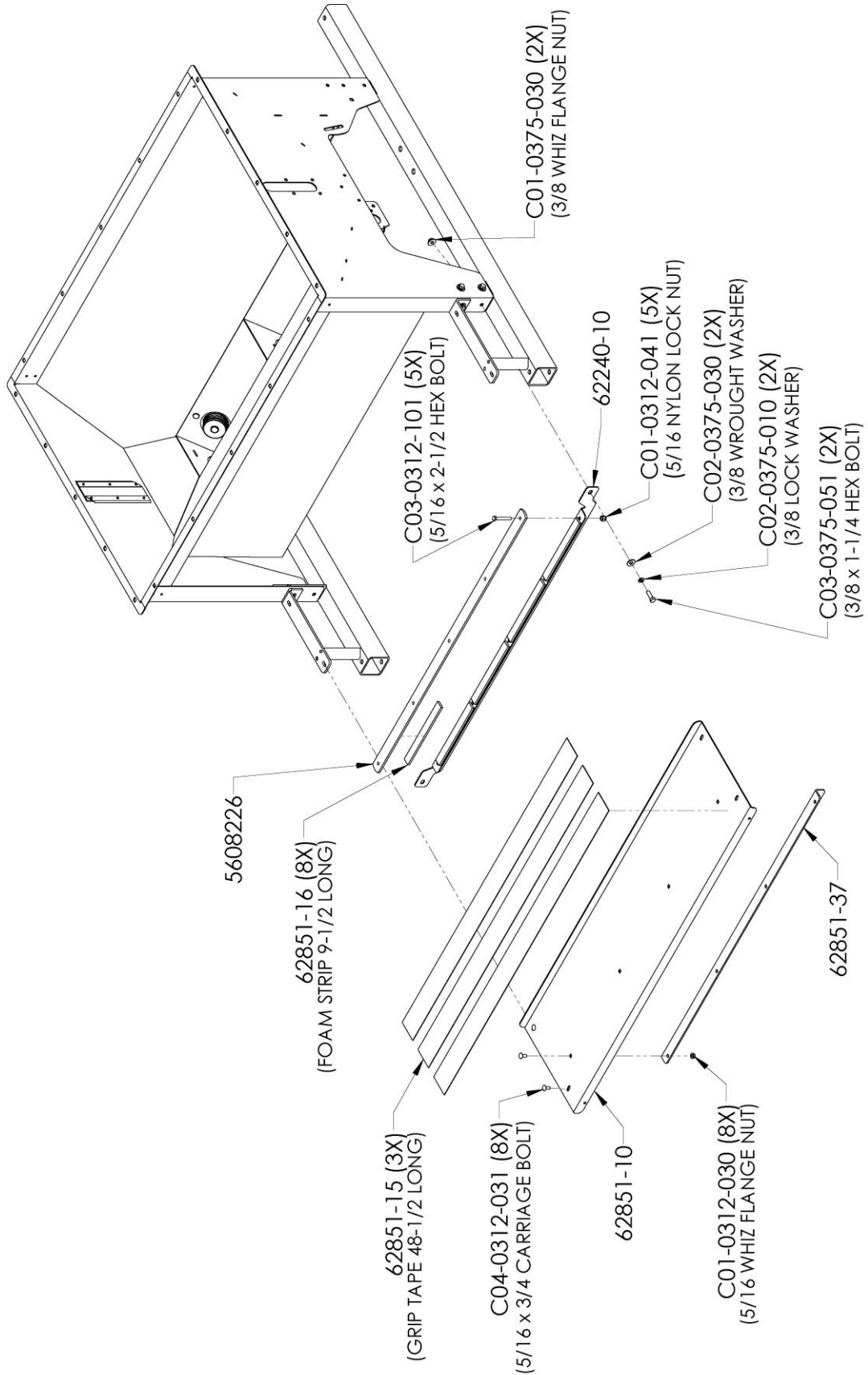

6223-A22

Electric Clutch w/Sprocket Assembly (Connected to Hydraulic Motor)

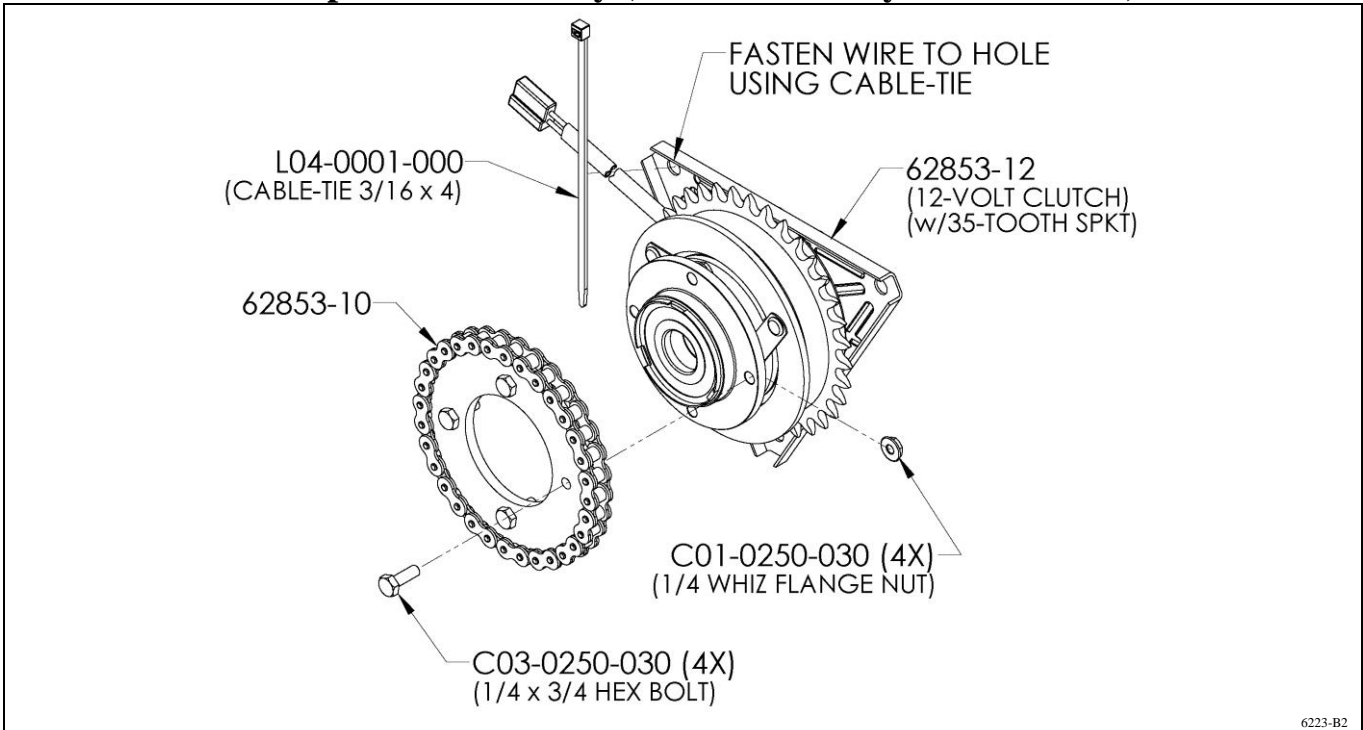

Electric Clutch Assembly

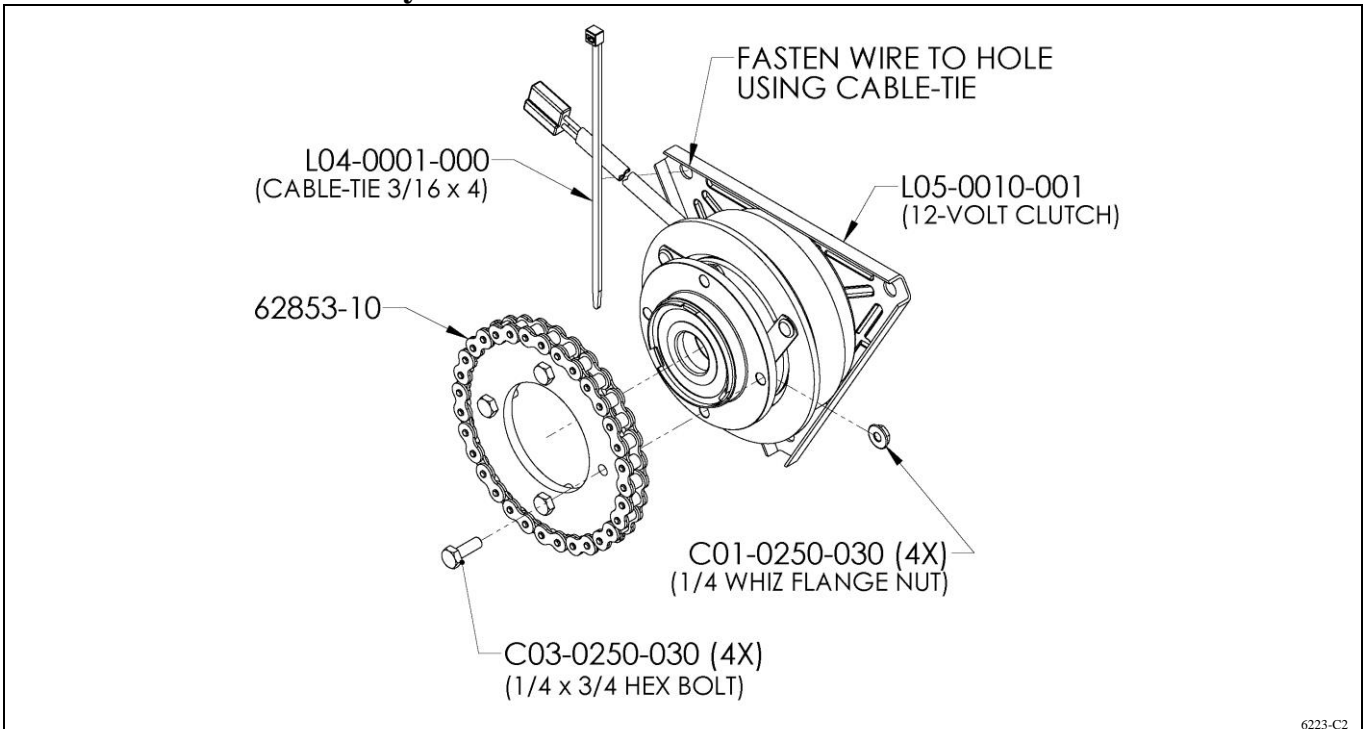

Drive Shaft Assembly

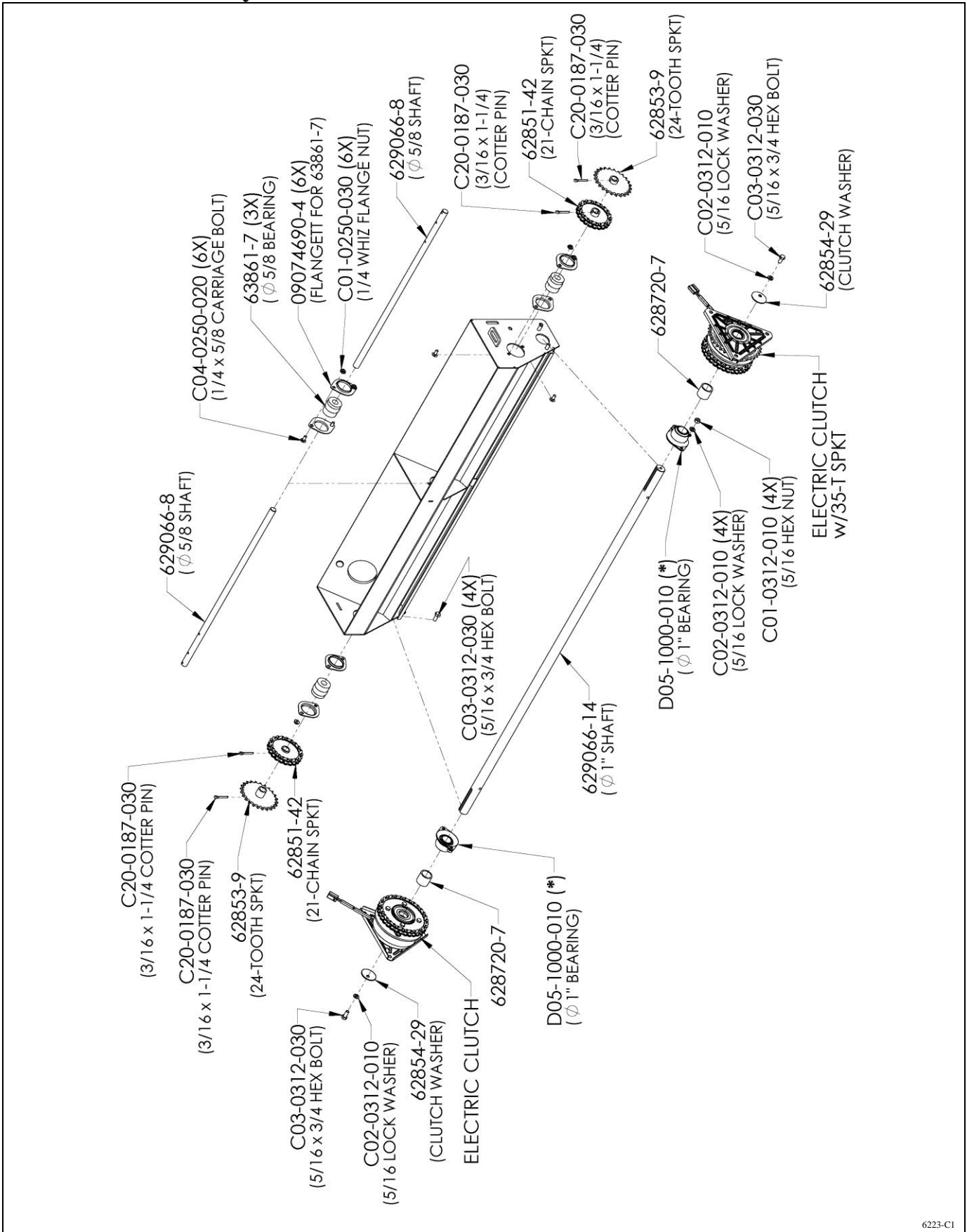

6223-C1

Part numbers with a (*) behind them have grease fittings. See last page.

Clutch Bracket Assembly (Hydraulic Motor Drive Side)

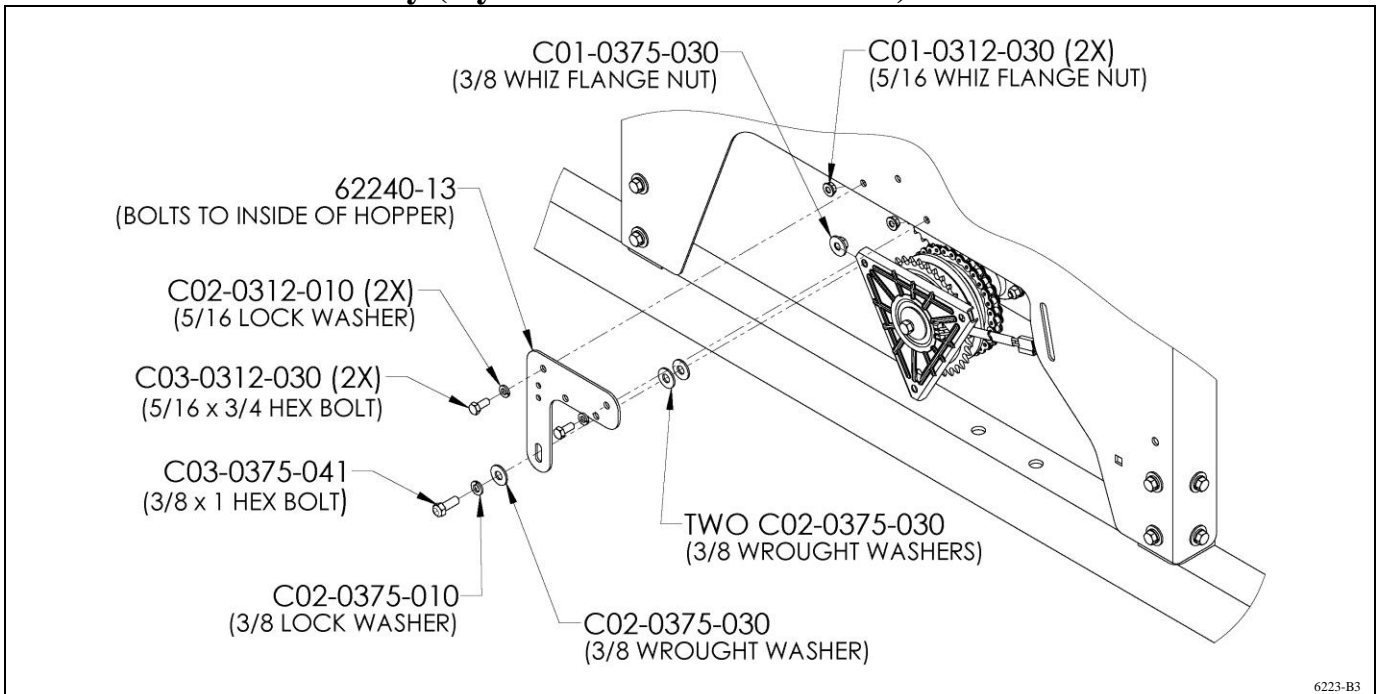

Clutch Bracket Assembly

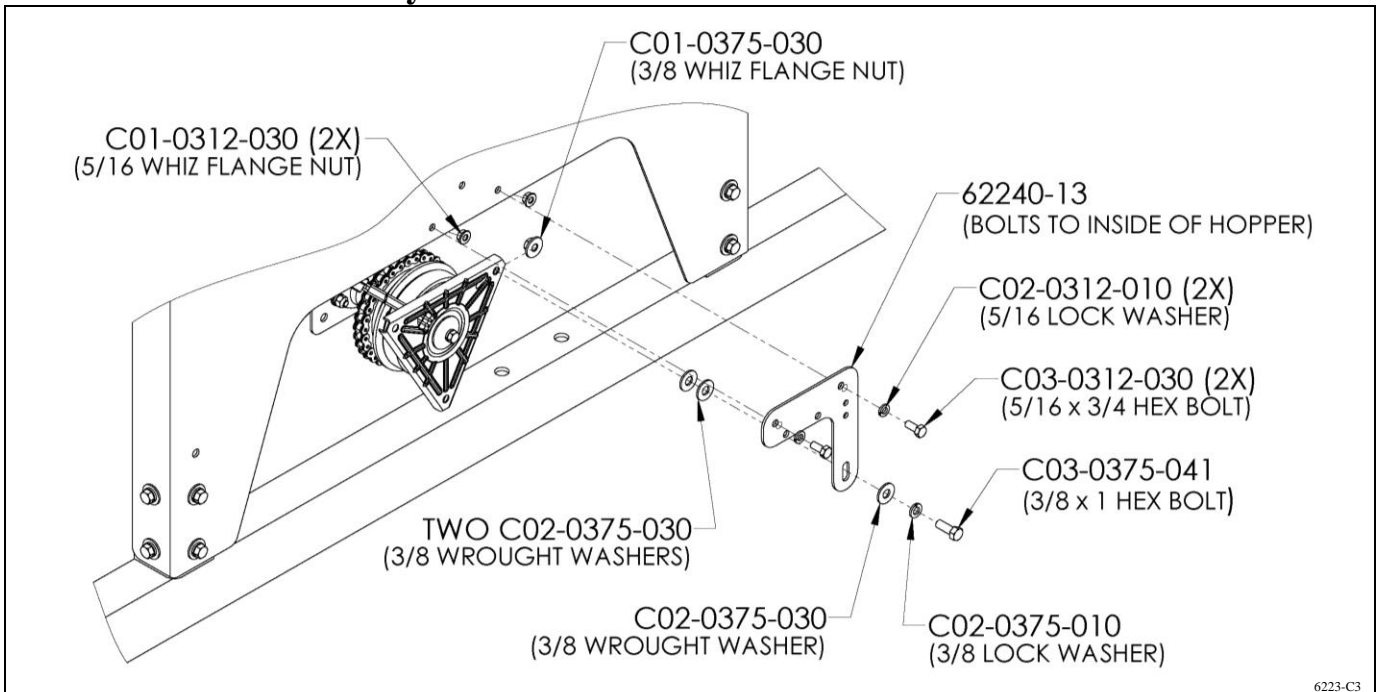

Metering Door Assembly (62851-B)

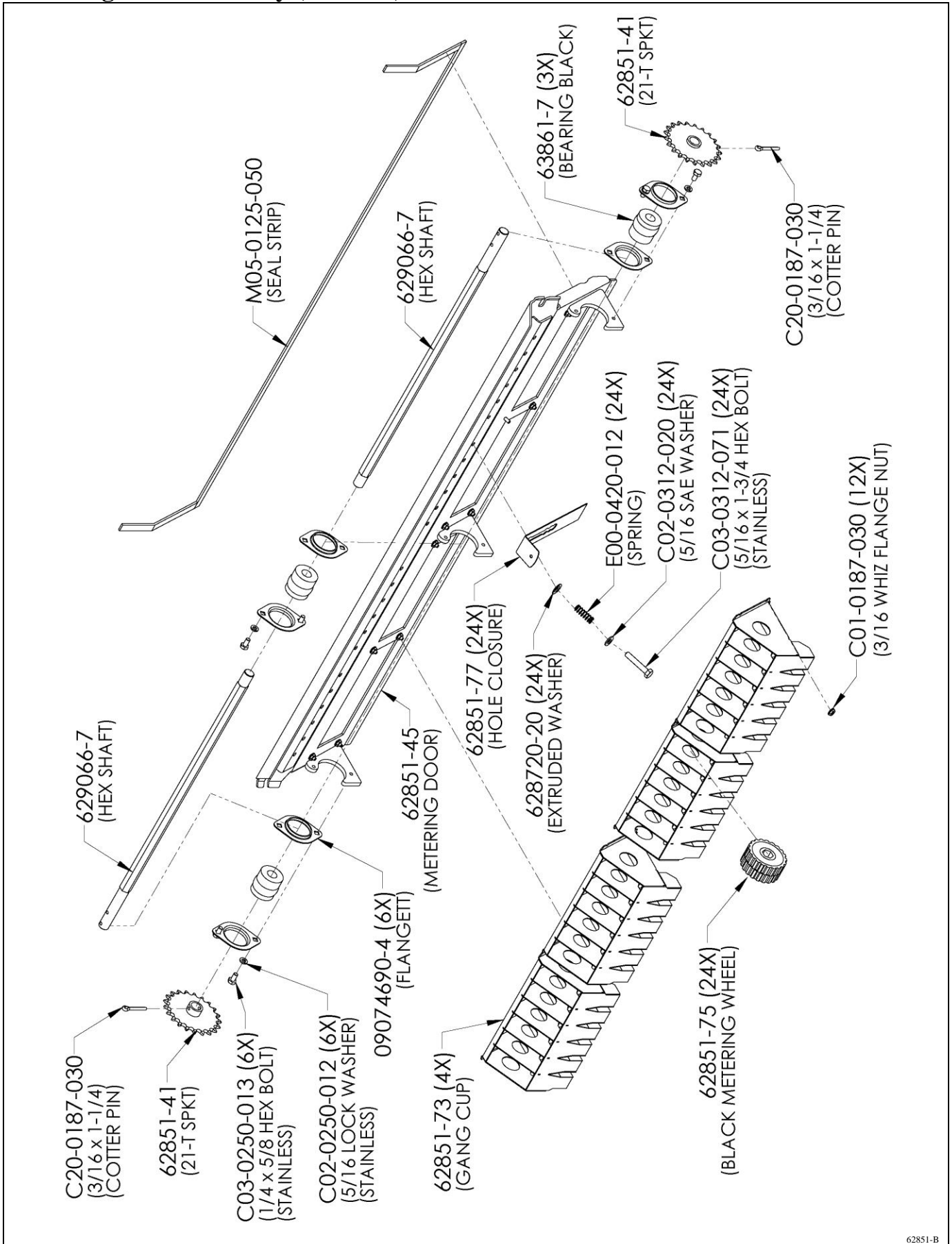

62851-B

Fastening Metering Door in Place (use one J-Bolt on each end of metering door)

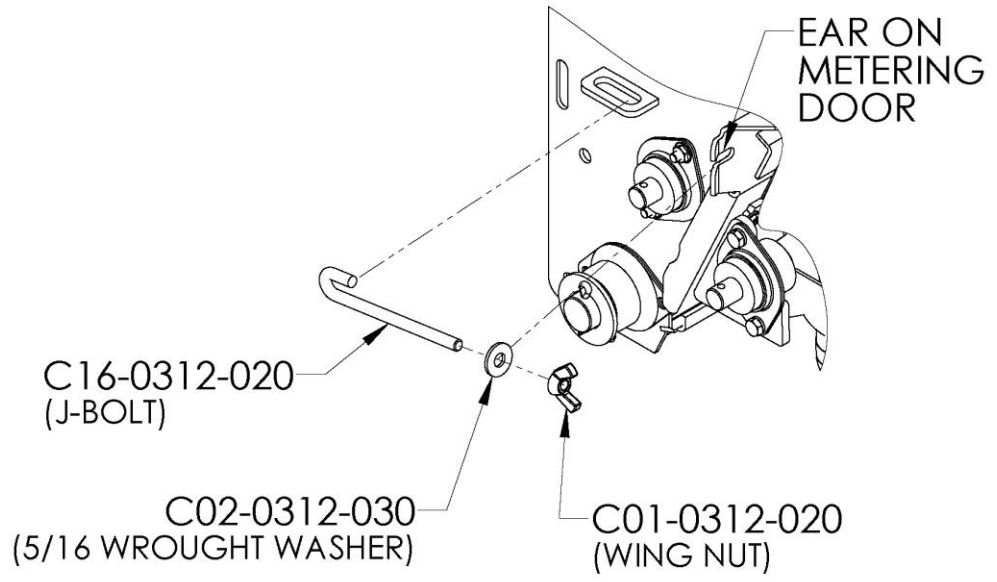

J-bolt shown in place.

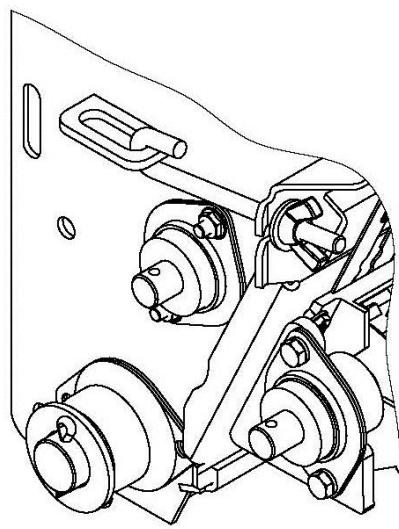

6223-B5

Air Chamber Assembly

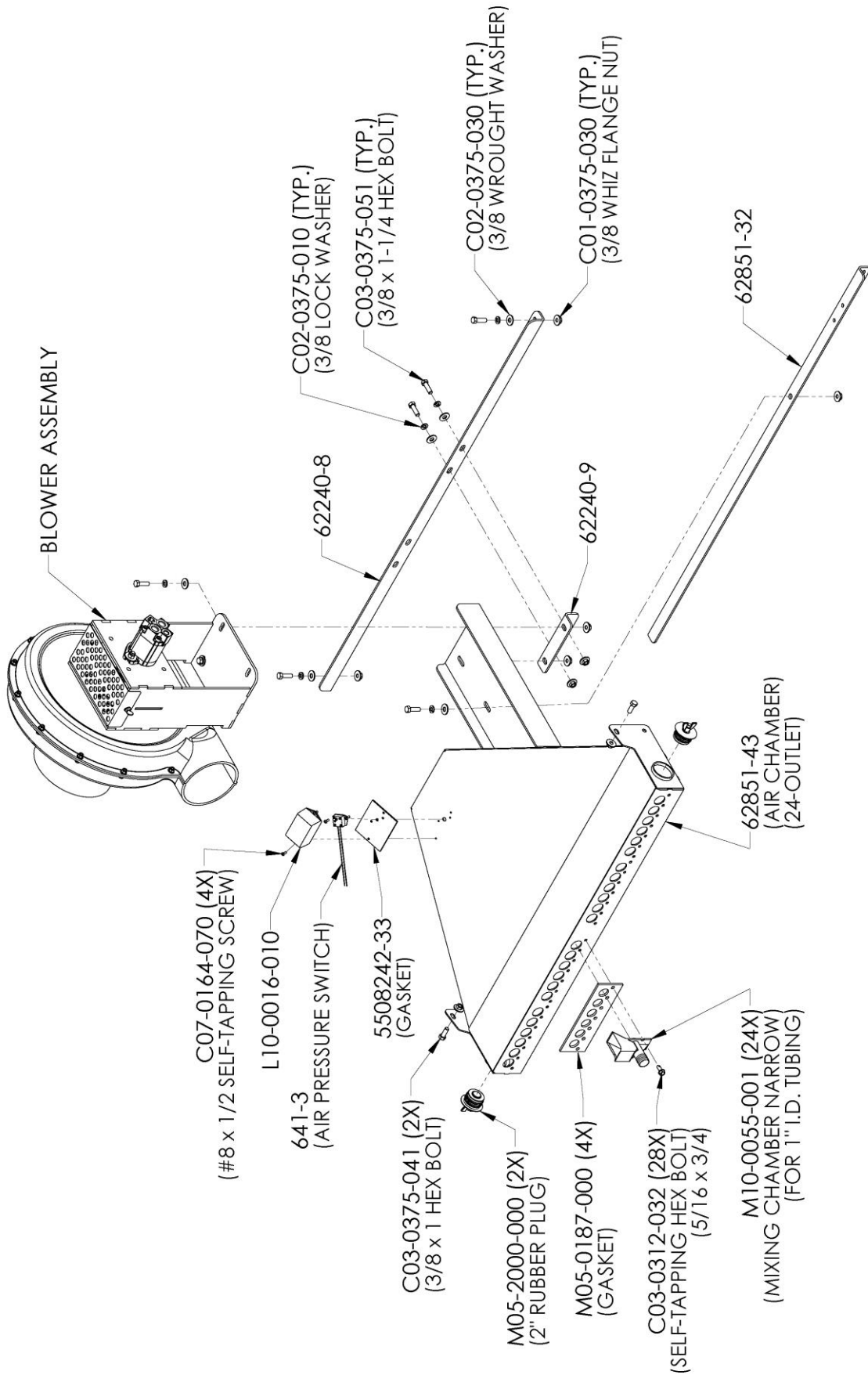

6623-C1

Hydraulic Blower Assembly (62167-P8LH)

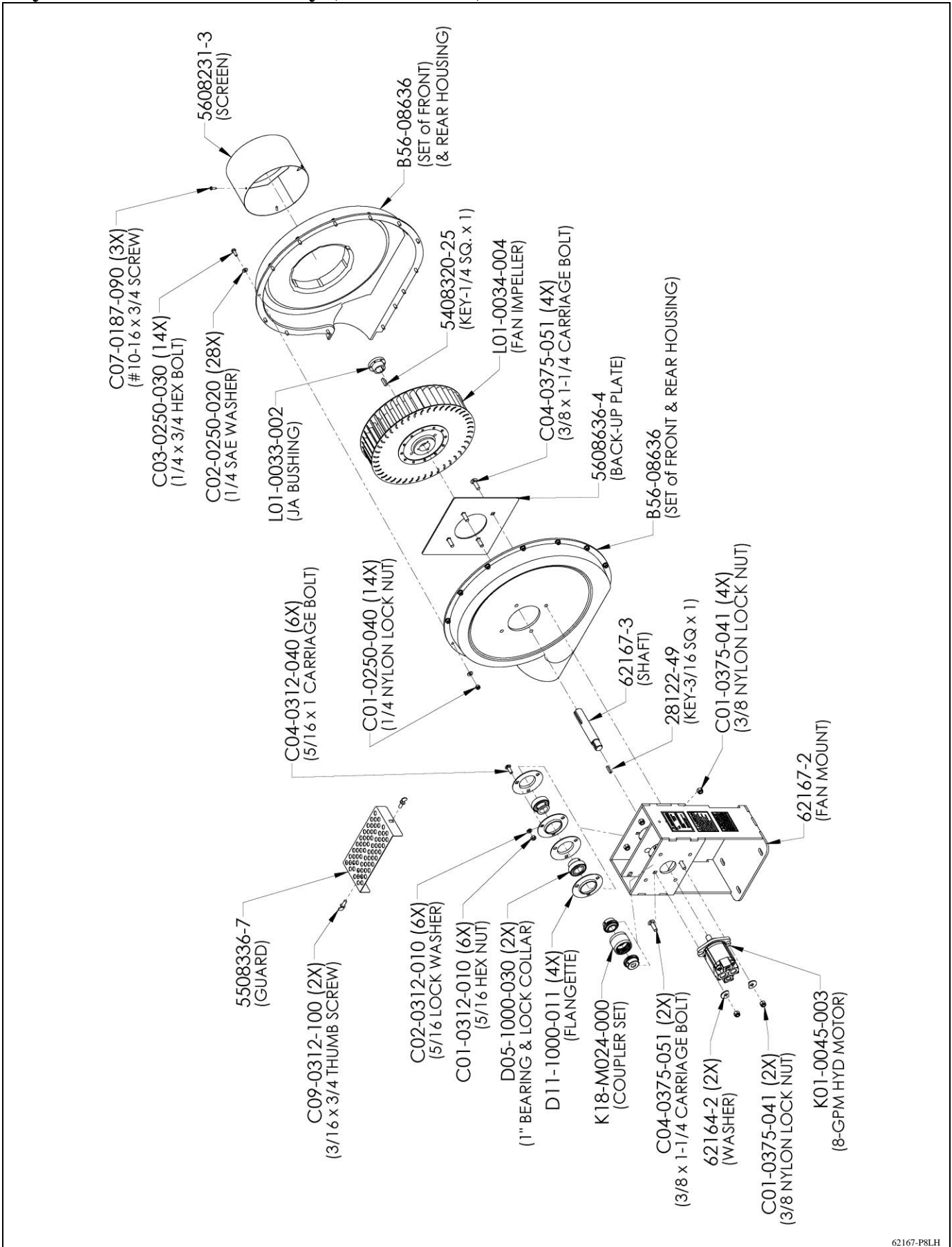

62167-P8LH

Hydraulic Motor Assembly (6623-A)

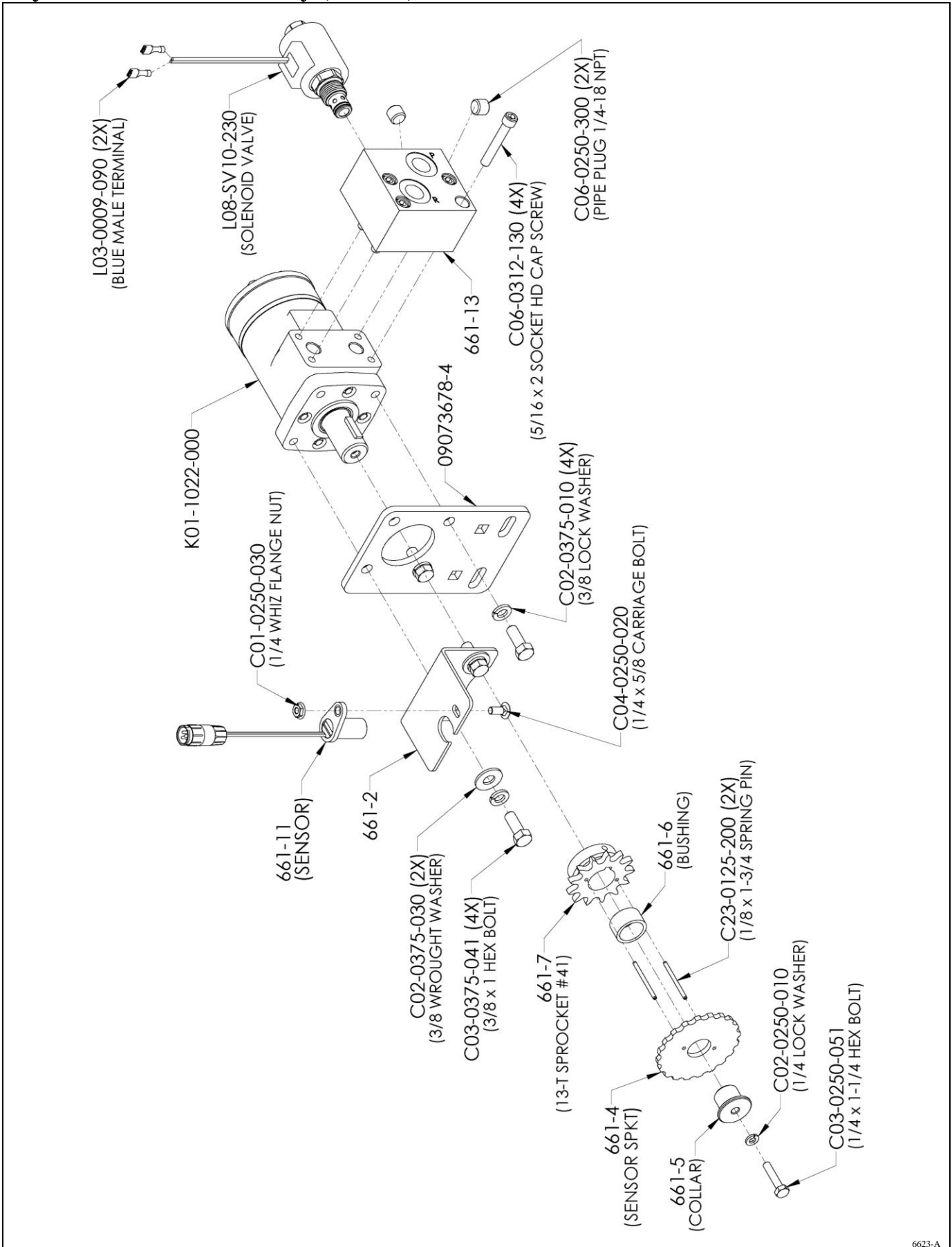

6623-A

Hydraulic Valve Assembly (6623-B)

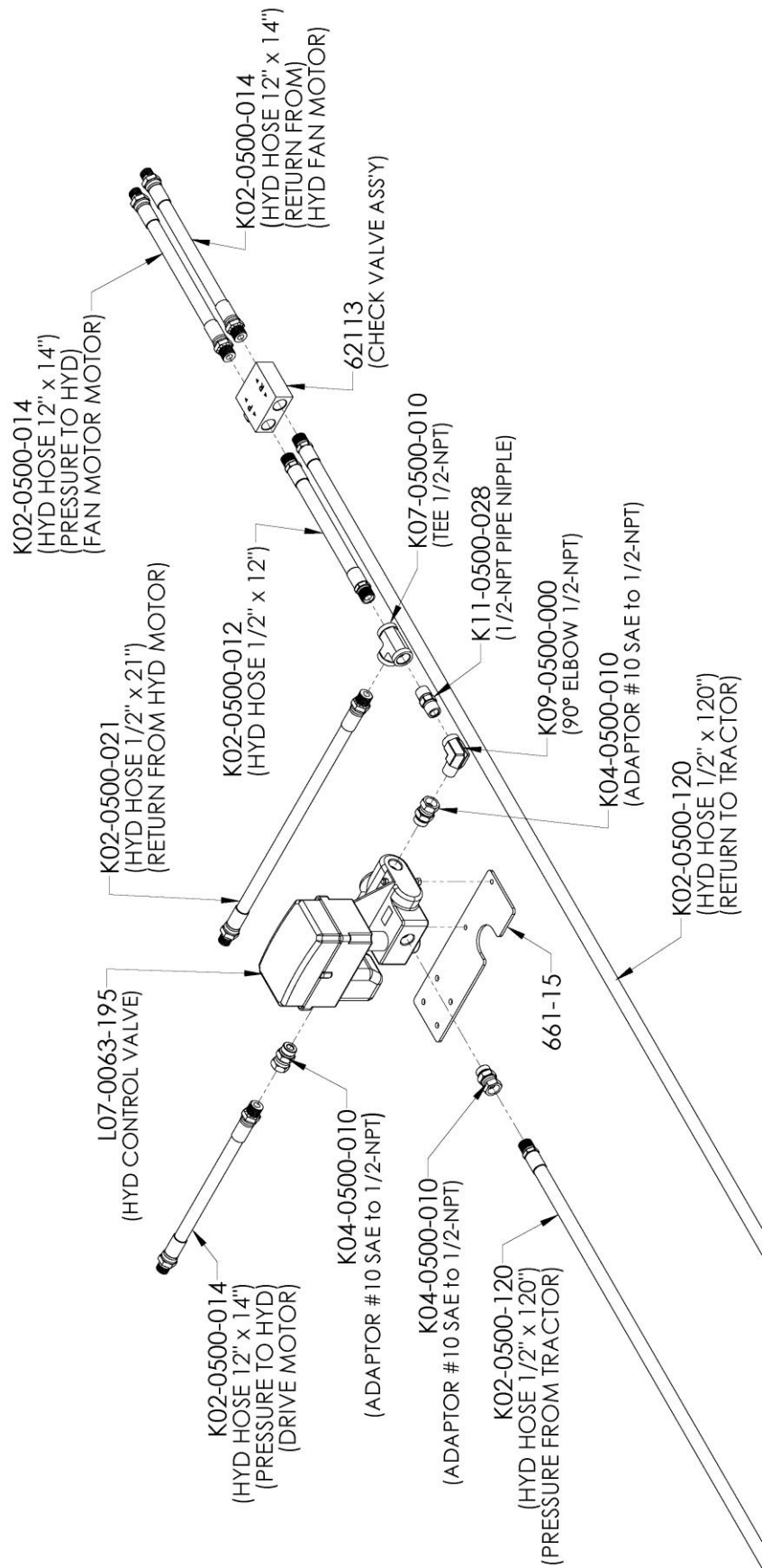

6623-B

Hydraulic Drive Assembly

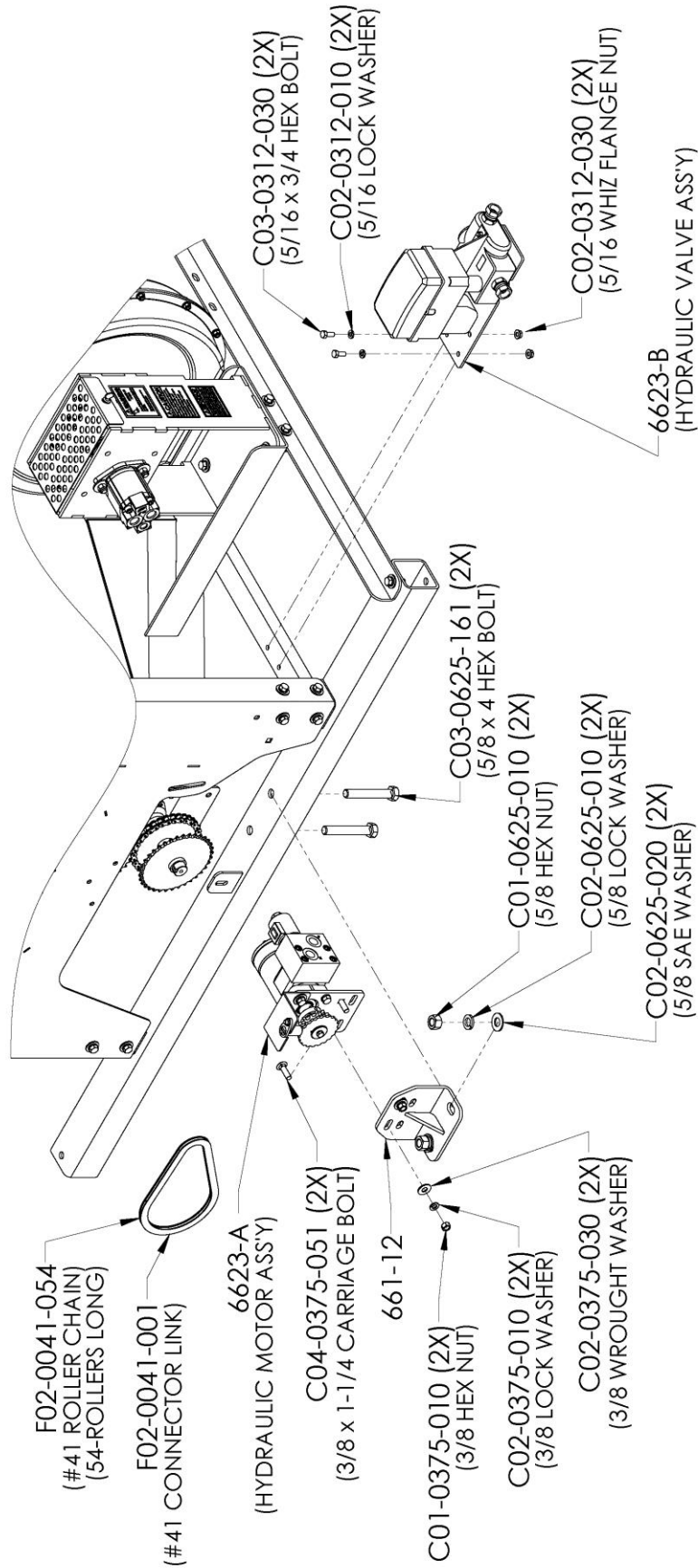

6623FS-A

Hydraulic Motor Hose Connections (Casappa 8-GPM Motor on Gandy Fan)

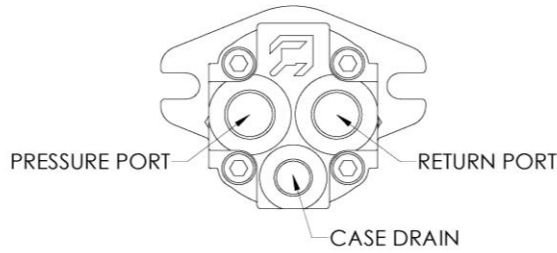

K01-0045-003

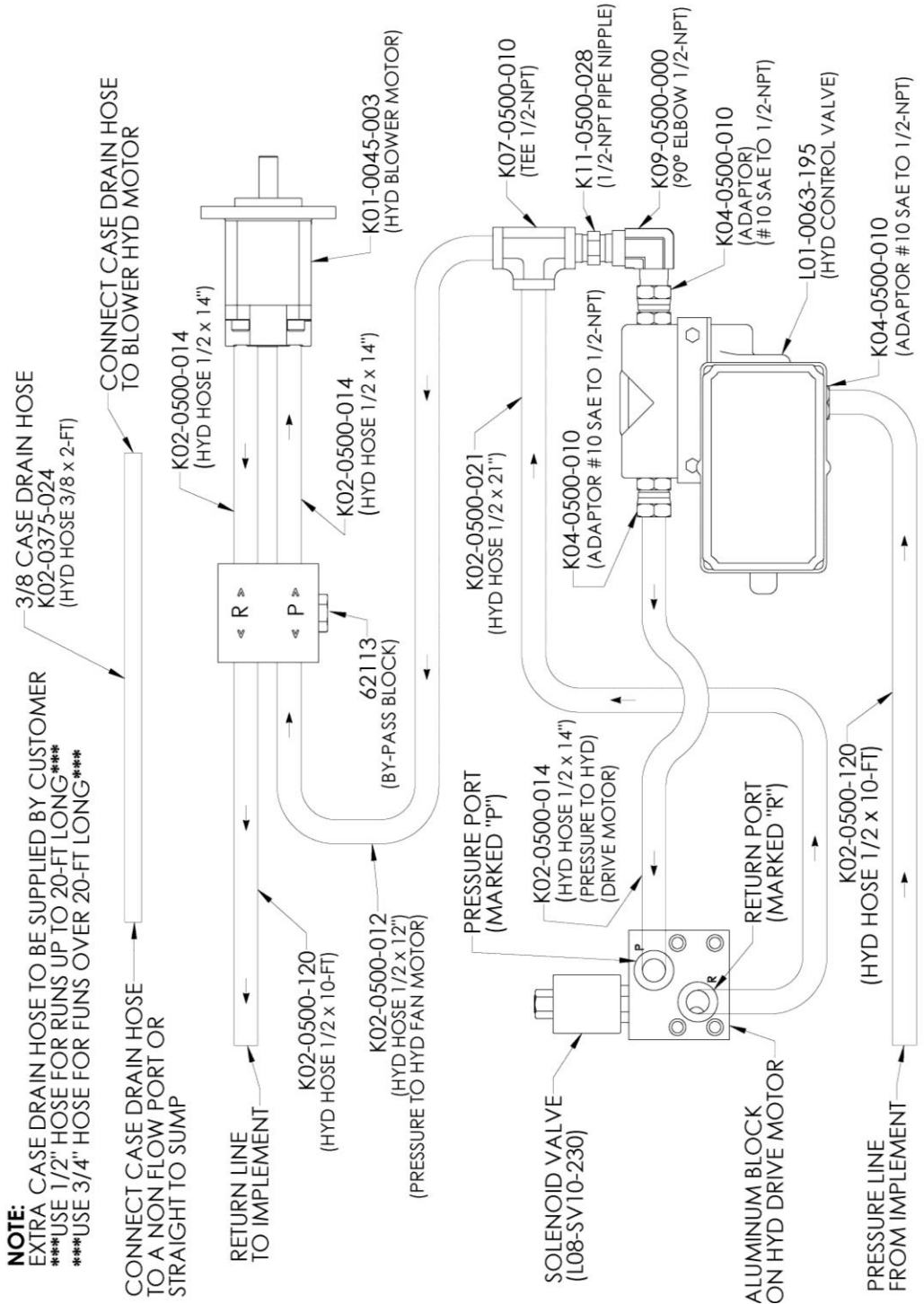

NOTE:

EXTRA CASE DRAIN HOSE TO BE SUPPLIED BY CUSTOMER
 USE 1/2" HOSE FOR RUNS UP TO 20-FT LONG
 USE 3/4" HOSE FOR RUNS OVER 20-FT LONG

CONNECT CASE DRAIN HOSE TO A NON-FLOW PORT OR STRAIGHT TO SUMP

RETURN LINE TO IMPLEMENT

K02-0500-120 (HYD HOSE 1/2 x 10-FT)

K02-0500-012 (HYD HOSE 1/2 x 12") (PRESSURE TO HYD FAN MOTOR)

62113 (BY-PASS BLOCK)

K02-0500-014 (HYD HOSE 1/2 x 14")

K02-0500-014 (HYD HOSE 1/2 x 14")

K01-0045-003 (HYD BLOWER MOTOR)

CONNECT CASE DRAIN HOSE TO BLOWER HYD MOTOR

K02-0500-014 (HYD HOSE 1/2 x 14")

K02-0500-021 (HYD HOSE 1/2 x 21")

K02-0500-014 (HYD HOSE 1/2 x 14") (PRESSURE TO HYD DRIVE MOTOR)

K04-0500-010 (ADAPTOR #10 SAE TO 1/2-NPT)

K09-0500-000 (90° ELBOW 1/2-NPT)

K07-0500-010 (TEE 1/2-NPT)

K04-0500-010 (ADAPTOR #10 SAE TO 1/2-NPT)

L01-0063-195 (HYD CONTROL VALVE)

K04-0500-010 (ADAPTOR #10 SAE TO 1/2-NPT)

K02-0500-120 (HYD HOSE 1/2 x 10-FT)

PRESSURE LINE FROM IMPLEMENT

6623-B1

Wiring Connections for Models w/ Two Clutches

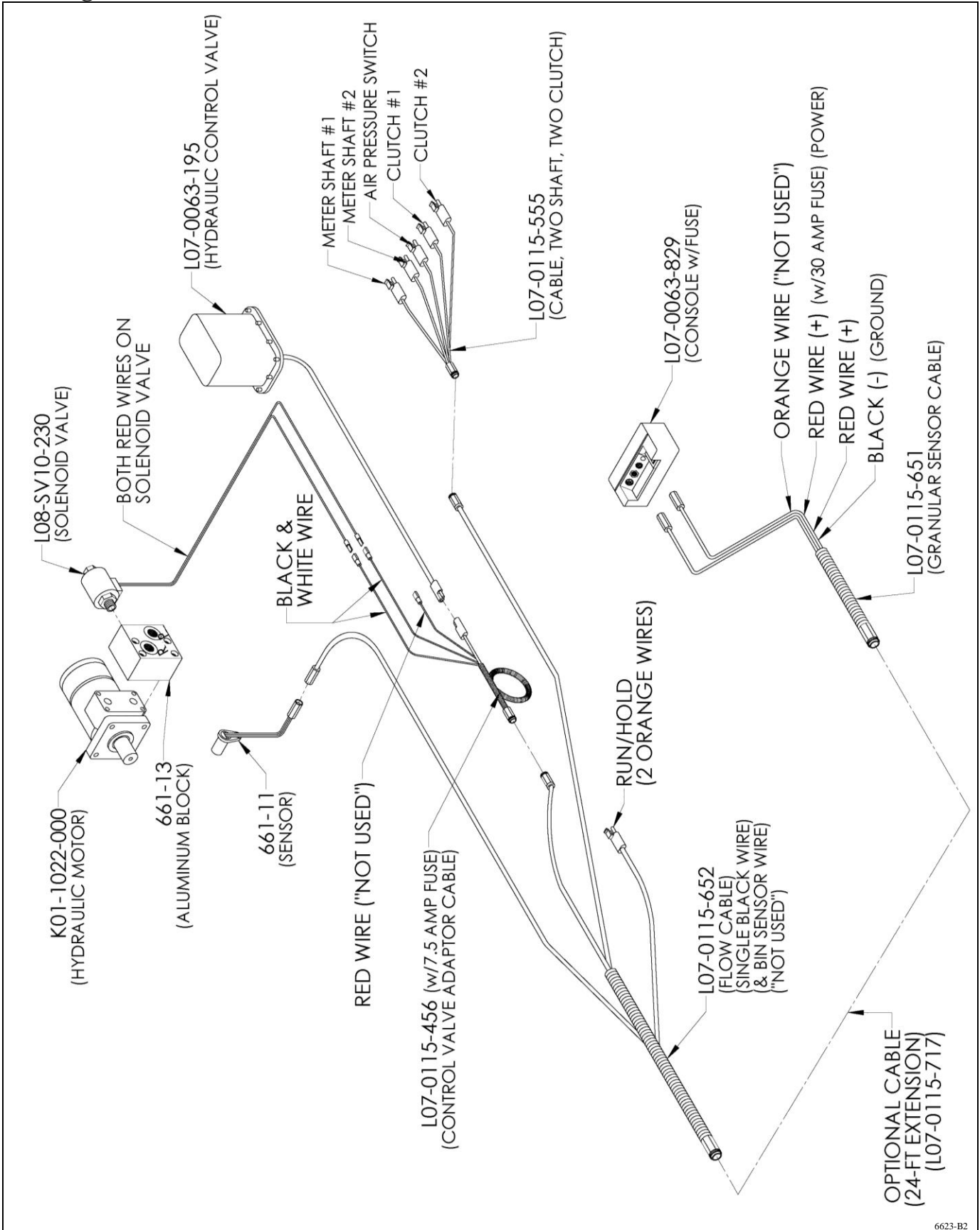

6623-B2

Shaft Sensor (Both Sides)

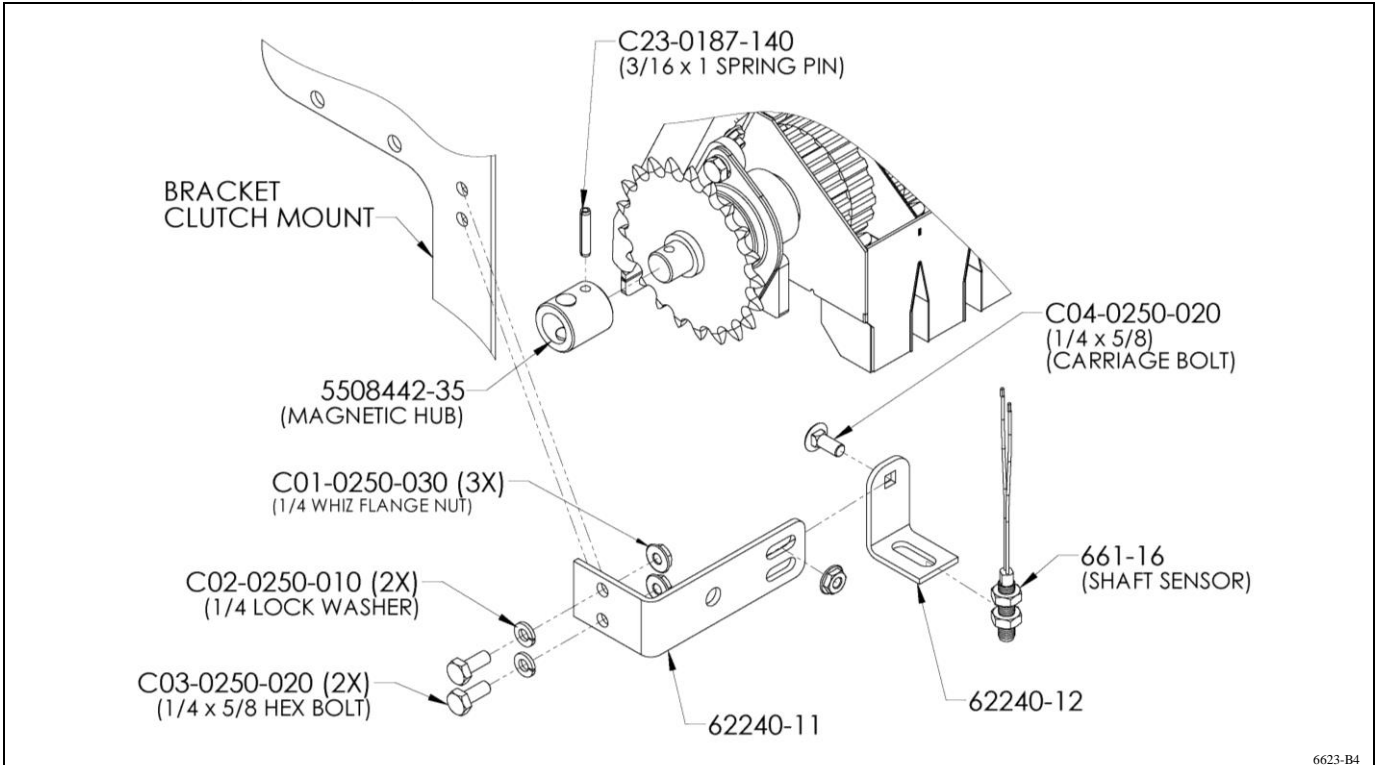

Hydraulic Drive Sensor

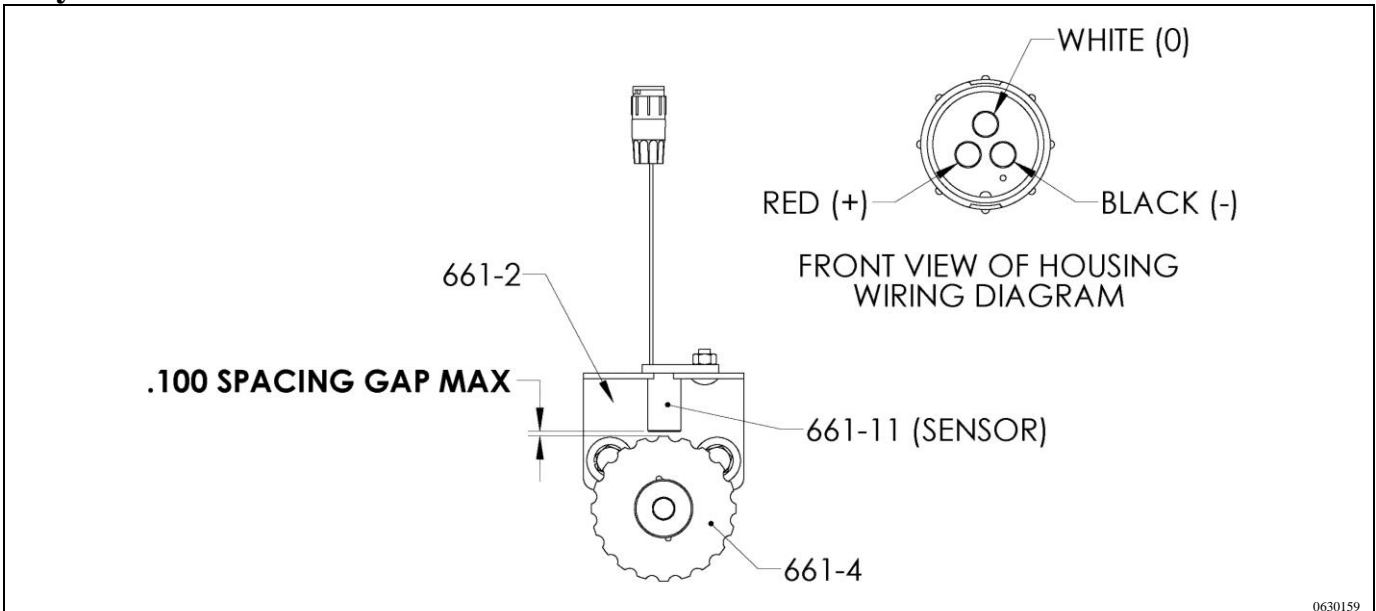

Decal Location (Drive Side)

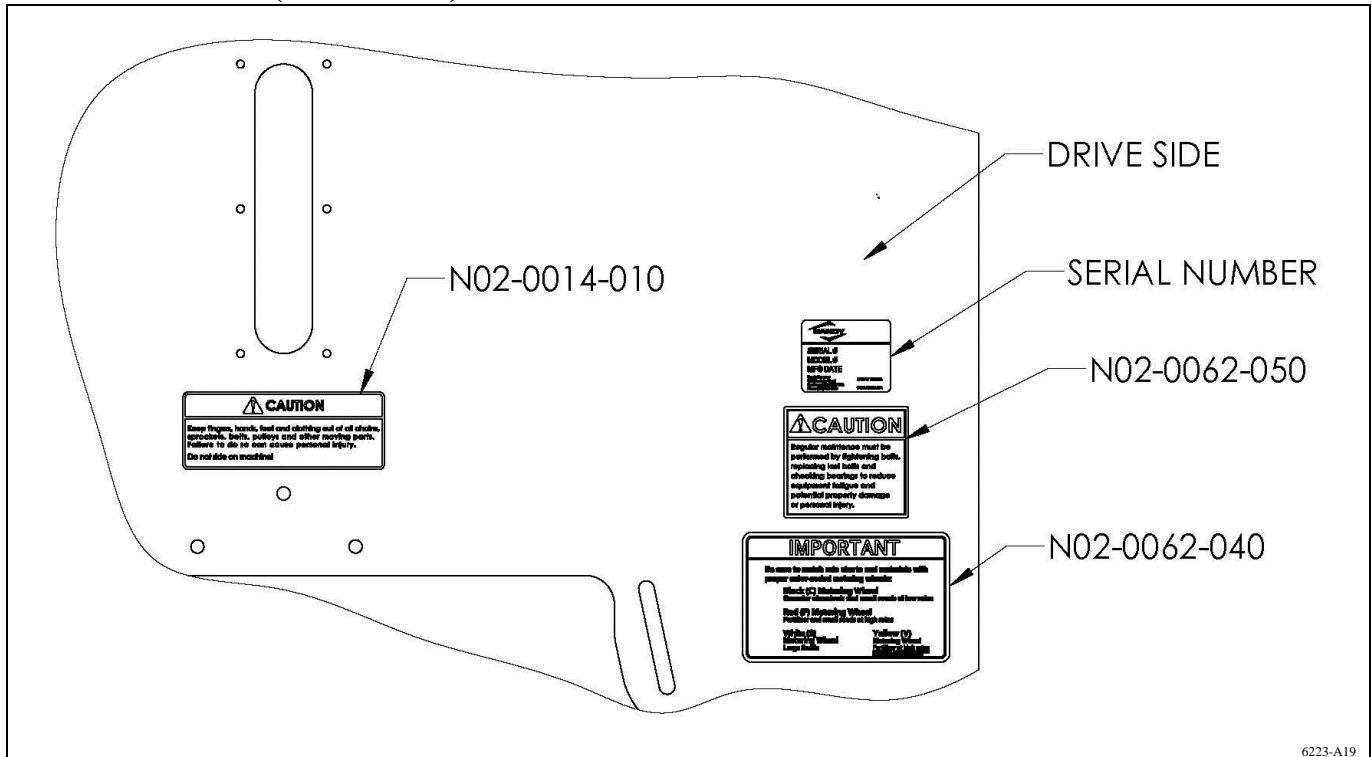

Decal Location (Opposite Side of Hopper)

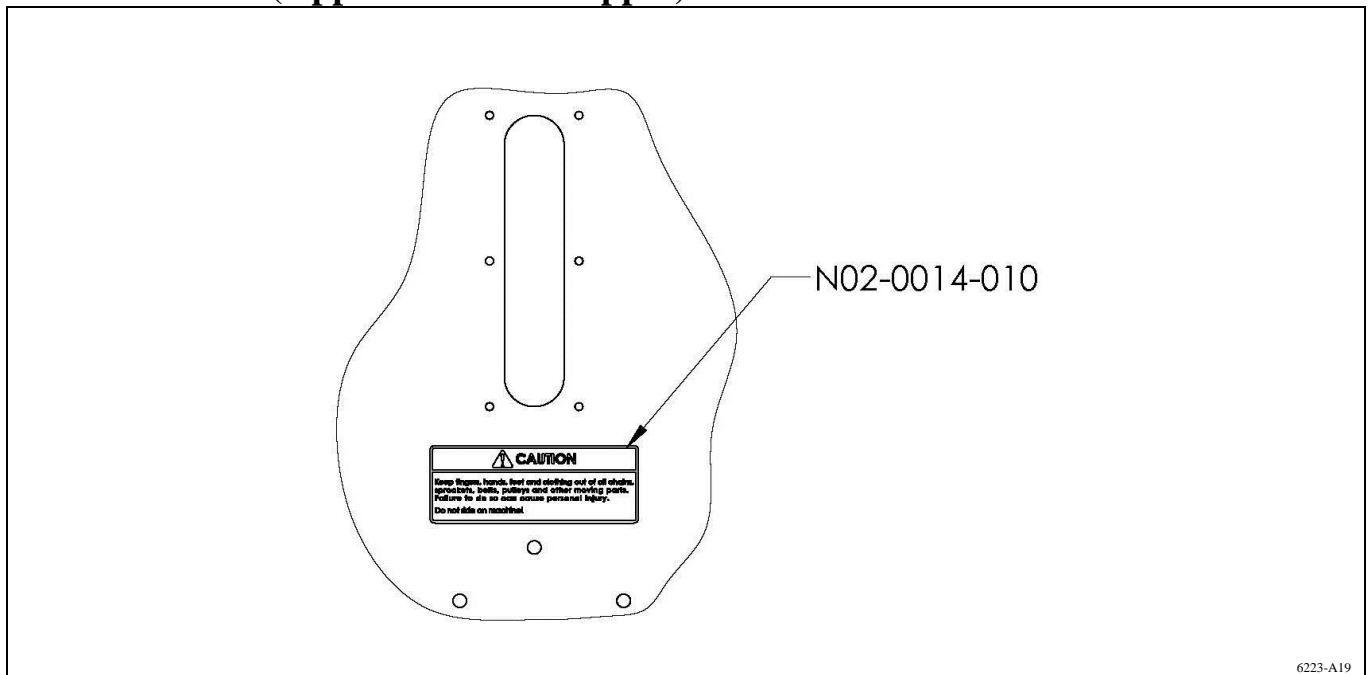

Clean-Out Decal Location

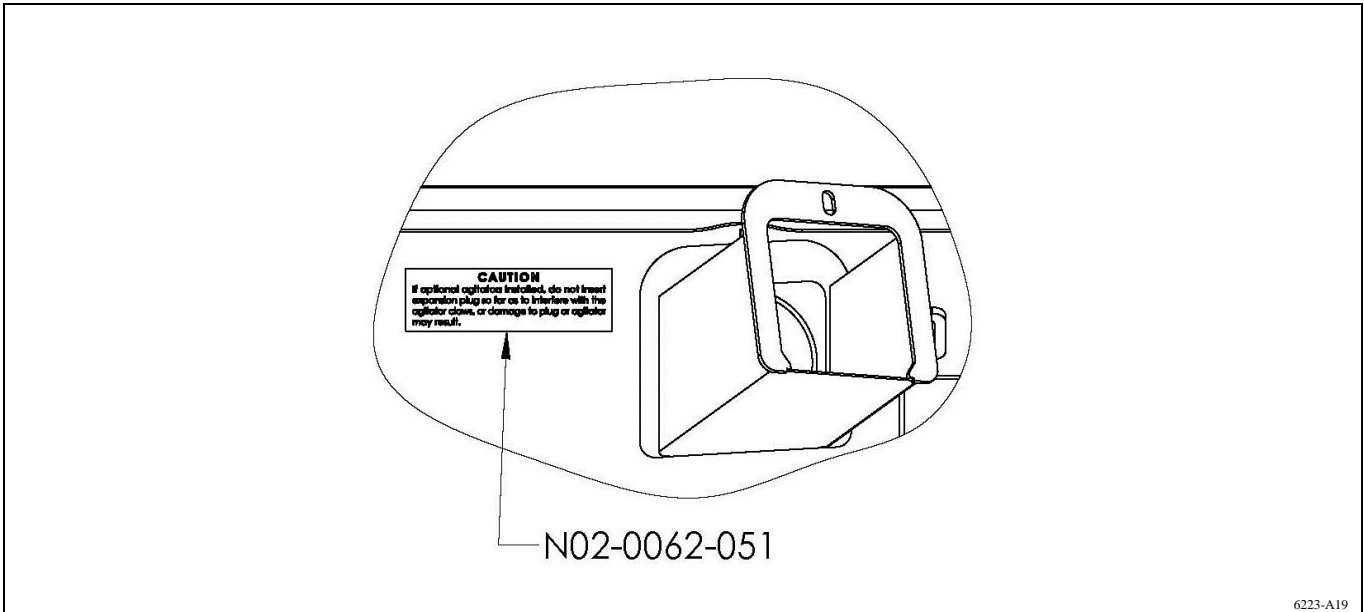

Front & Rear & End Decals

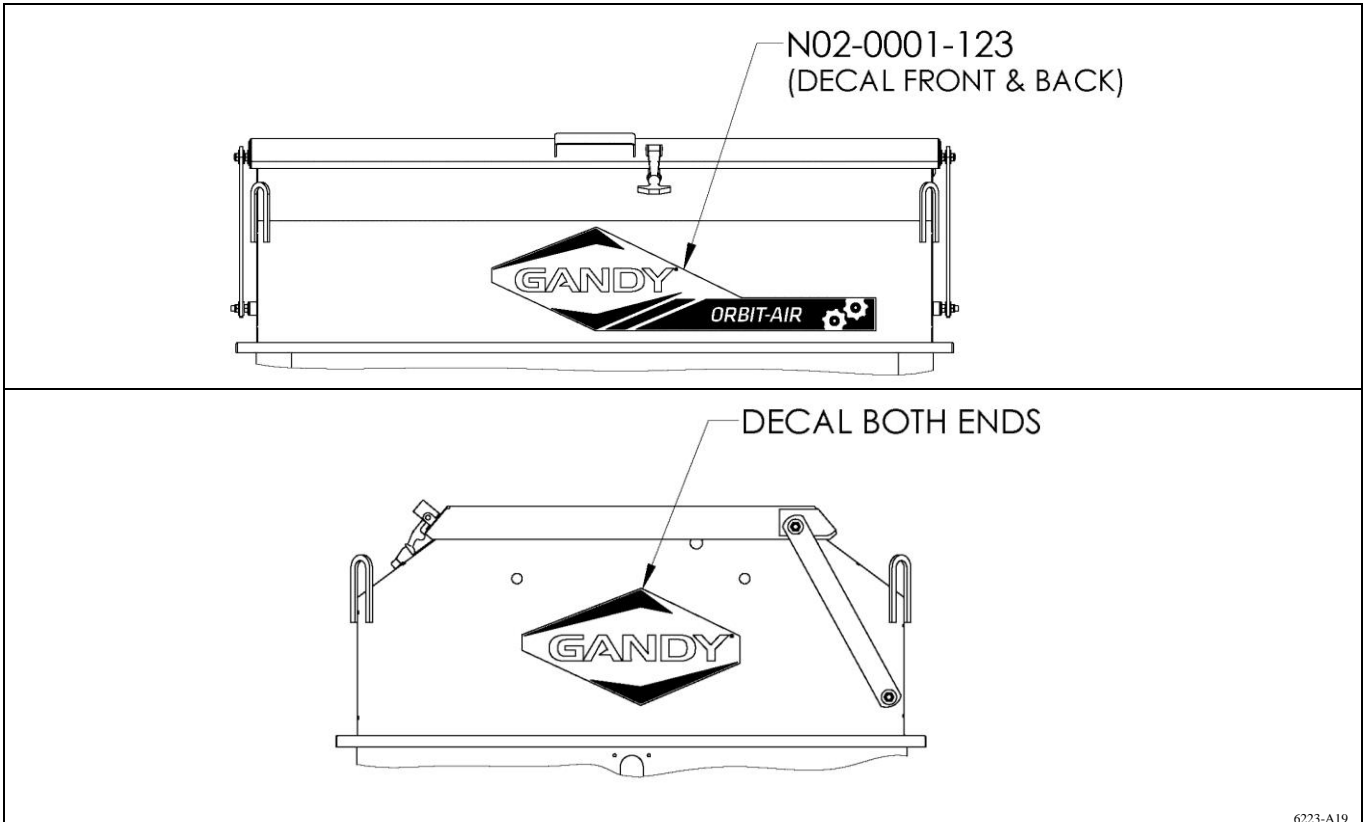

Run Hold Switch

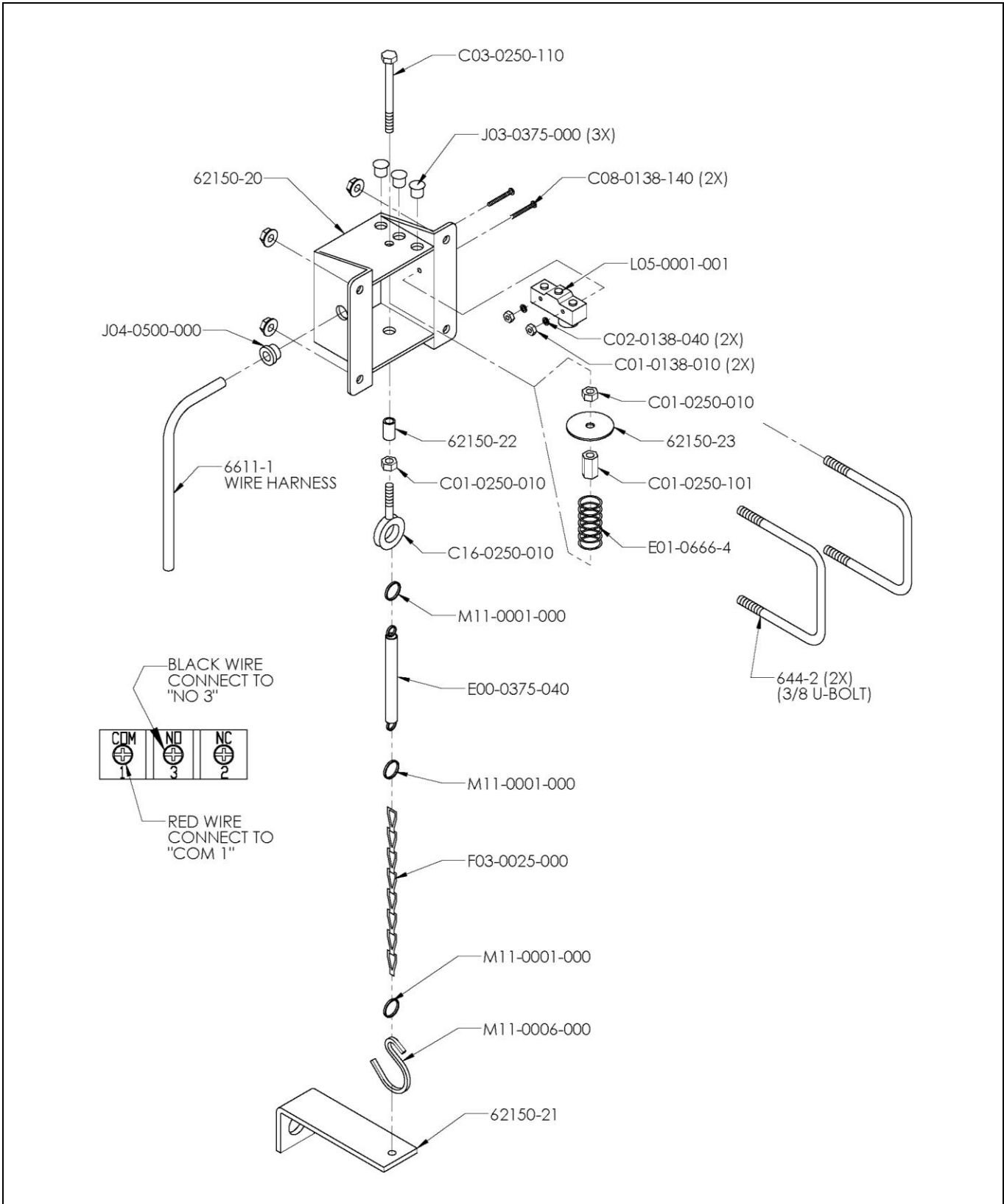

Air Chamber Blank Plates:

Blank Plate (62851-48) is used to block off unused air chamber openings when not needed.

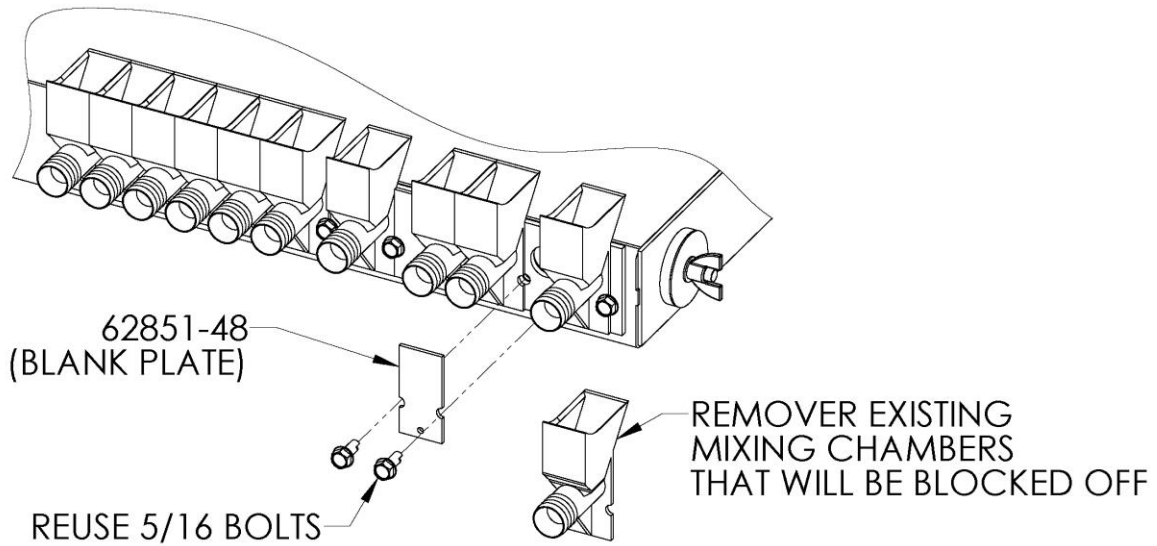

6223-A26

Metering Door Blank Plate:

Blank Plate (62851-66) is used to block off unused metering door openings when not needed.

To remove shaft; First remove sensor hub from shaft, then unbolt bearing flange by sprocket on metering shaft and pull shaft out. Reassembly by reversing instructions.

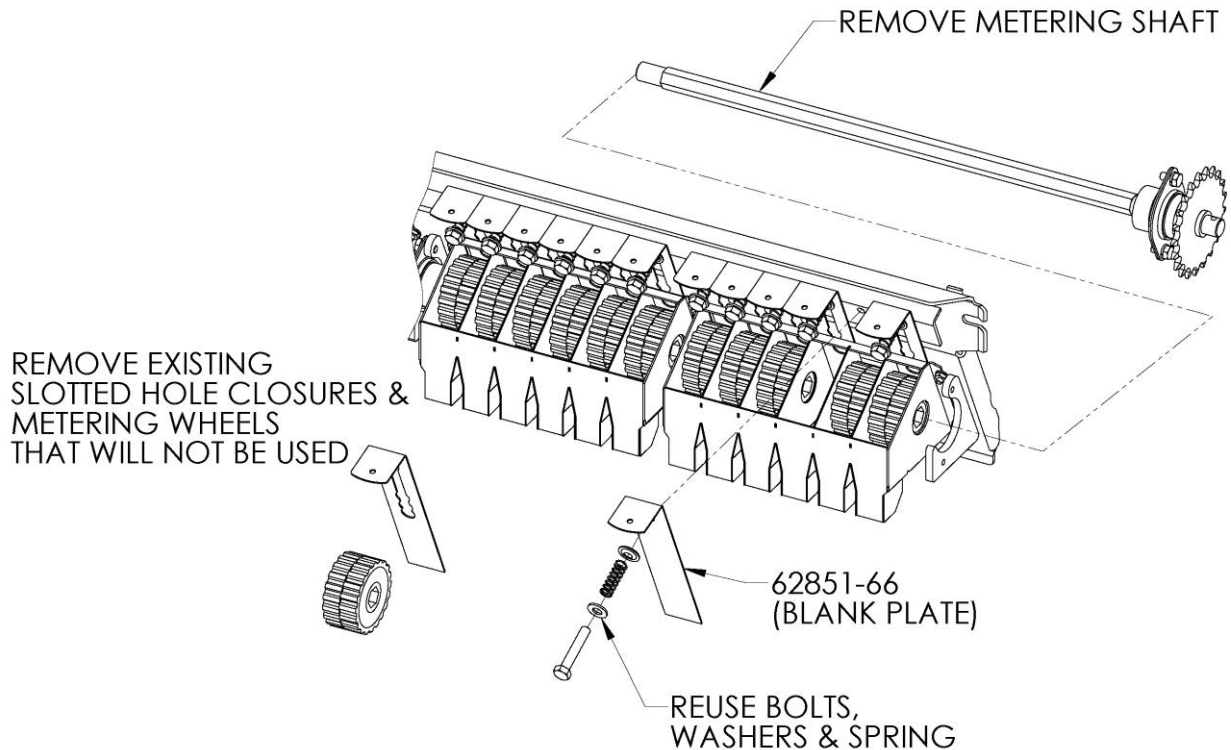

6223-A24

Manual Holder Bracket

Mount manual holder to corner of hopper or convergent location on implement.
Store Operator's manual, Packing List & Rate Chart of convergent access.

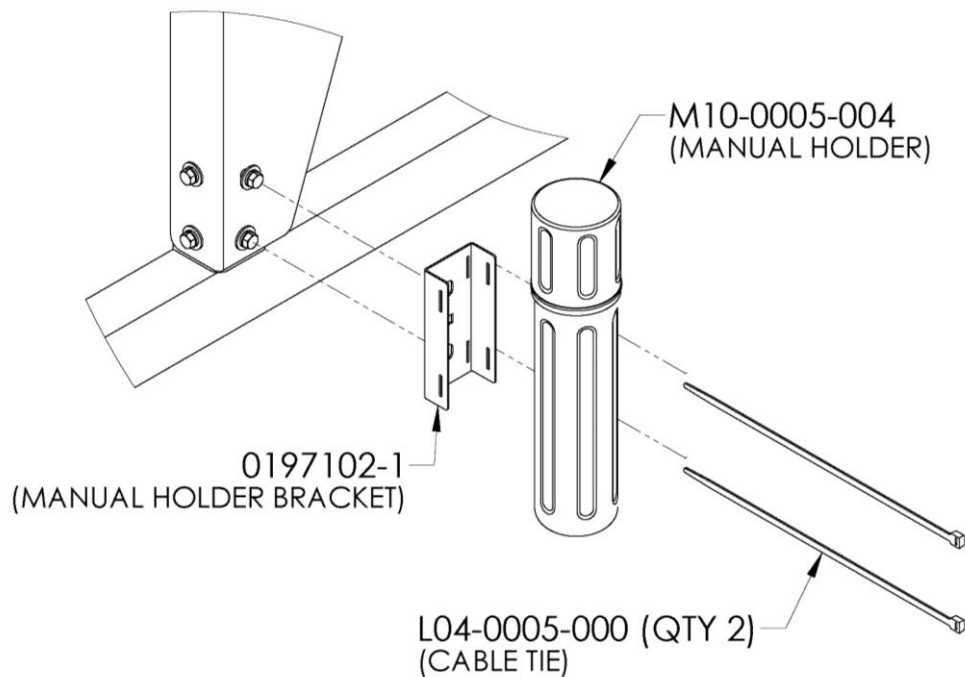

HOLDER-1

Maintenance

Check all bolts for tightness after first two hours of use; check periodically thereafter.

Grease all fittings regularly.

There are **Two** grease fittings on this hopper. These **must** be greased before use and periodically during use.

Locations: See page 15.

One grease fitting on each 1-inch bearing (D05-1000-010) (two) located on the 1-inch drive shaft (629066-14).

Lucubrate chains as needed.

Periodically clean intake screen on hydraulic driven blower.

See Raven Operator's Manual for operating and wiring instructions.

(6631GN24C)
April 30, 2018
Printed in the USA