



Illustrated Parts & Packing List

815 Rice Lake Street, Owatonna, MN 55060

For a complete distributor & dealer list go to www.gandy.net

4908048

18 x 48 Lawn Roller

(All Hardware in Hardware Bag Unless Otherwise Specified)

Crate Containing The Following:

- 1 4908048-3.....Drum (18 x 48 Roller)
- 1 49A8048.....Lawn Roller Bag Containing The Following
 - 1 4908024-5.....Hitch-Handle
 - 2..... 4908048-4.....Mounting Arm, Hitch
 - 1 4908048-6.....Scraper Angle
 - 1 49H8048.....Hardware Bag (see page 3 for contents)
 - 1..... Parts & Packing List

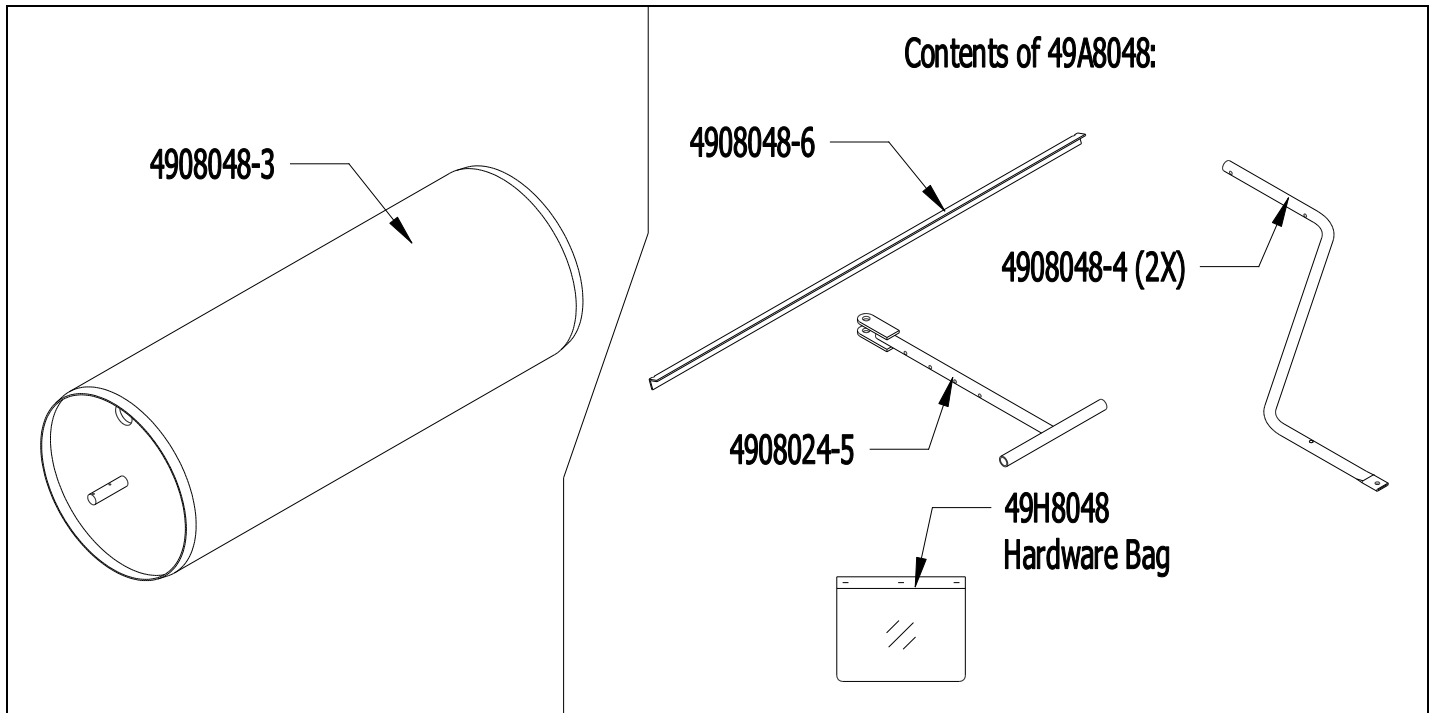

18 x 48 Roller Complete Parts List

(All hardware in hardware bag unless otherwise specified.)

- 1 4908048-3 Drum (18 x 48 Roller)
Use: 2 Decal, Gandy Diamond (N02-0001-093) **(in Place)**
- 1 49A8048 Lawn Roller Bag Containing The Following:**
 - 1 4908024-5 Hitch-Handle
Use: 2 Grip (1 x 4-5/8) (J01-1000-462)
2 Hex Bolt (5/16 x 3-1/2) (C03-0312-141)
4 Wrought Washer (5/16) (C02-0312-030)
2 Wing Nut (5/16) (C01-0312-020)
 - 2 4908048-4 Mounting Arm, Hitch
Use: 2 Plastic Plug (3/4) (J02-0750-050)
2 Carriage Bolt (3/8 x 1) (C04-0375-040)
2 Whiz Flange Nut (3/8) (C01-0375-030)
 - 1 4908048-6 Scraper Angle
 - 1 49H8048 Hardware Bag
 - 1 Parts & Packing List

All the following parts are shipped in Hardware Bag 49H8048

- 2 4908048-7 Mounting Bracket Arm (Bearing) **(Grease Before Use)**
Use: 2 Grease Fitting (D01-5010-050) **(in Place on Bearing)**
4 SAE Washer (1-inch) (C02-1000-020)
4 Cotter Pin (3/16 x 1-1/2) (C20-0187-040)
- 2 M05-2000-010 Rubber Plug 2-Inch Snap-Tite (M05-2000-010)
Use: 4 S-Hook #63 (M11-0063-000)
2 Sash Chain #25 (8-Links Long) (F03-0025-008)
- 2 4908024-8 Mounting Bracket, Scraper
Use: 2 Spring (E01-05215-3)
2 Hex Bolt (1/4 x 2-1/4) (C03-0250-090)
2 Lock Nut, Nylon (1/4) (C01-0250-040)
2 Carriage Bolt (5/16 x 1-1/2) (C04-0312-060)
2 Whiz Flange Nut (5/16) (C01-0312-030)

Continued on next page.

- 1.....49H8048Hardware Bag Containing**
- 2 C01-0250-040.....Lock Nut, Nylon (1/4)
 - 2 C01-0312-020.....Wing Nut (5/16)
 - 2 C01-0312-030.....Whiz Flange Nut (5/16)
 - 2 C01-0375-030.....Whiz Flange Nut (3/8)
 - 4 C02-0312-030.....Wrought Washer (5/16)
 - 4 C02-1000-020.....SAE Washer (1-Inch)
 - 2 C03-0250-090.....Hex Bolt (1/4 x 2-1/4)
 - 2 C03-0312-141.....Hex Bolt (5/16 x 3-1/2)
 - 2 C04-0312-060.....Carriage Bolt (5/16 x 1-1/2)
 - 2 C04-0375-040.....Carriage Bolt (3/8 x 1)
 - 4 C20-0187-040.....Cotter Pin (3/16 x 1-1/2)
 - 2 E01-05215-3Spring
 - 2 F03-0025-008Sash Chain #25 (8-Links Long)
 - 2 J01-1000-462.....Grip (1 x 4-5/8)
 - 2 J02-0750-050.....Plastic Plug (3/4) (J02-0750-050)
 - 2 M05-2000-010.....Rubber Plug 2-Inch Snap-Tite
 - 4 M11-0063-000.....S-Hook #63
 - 2 4908024-8.....Mounting Bracket, Scraper
 - 2 4908048-7.....Mounting Bracket, Arm (Bearing) (with D01-5010-050 Grease Fitting In Place)

Hardware Bag Contents:

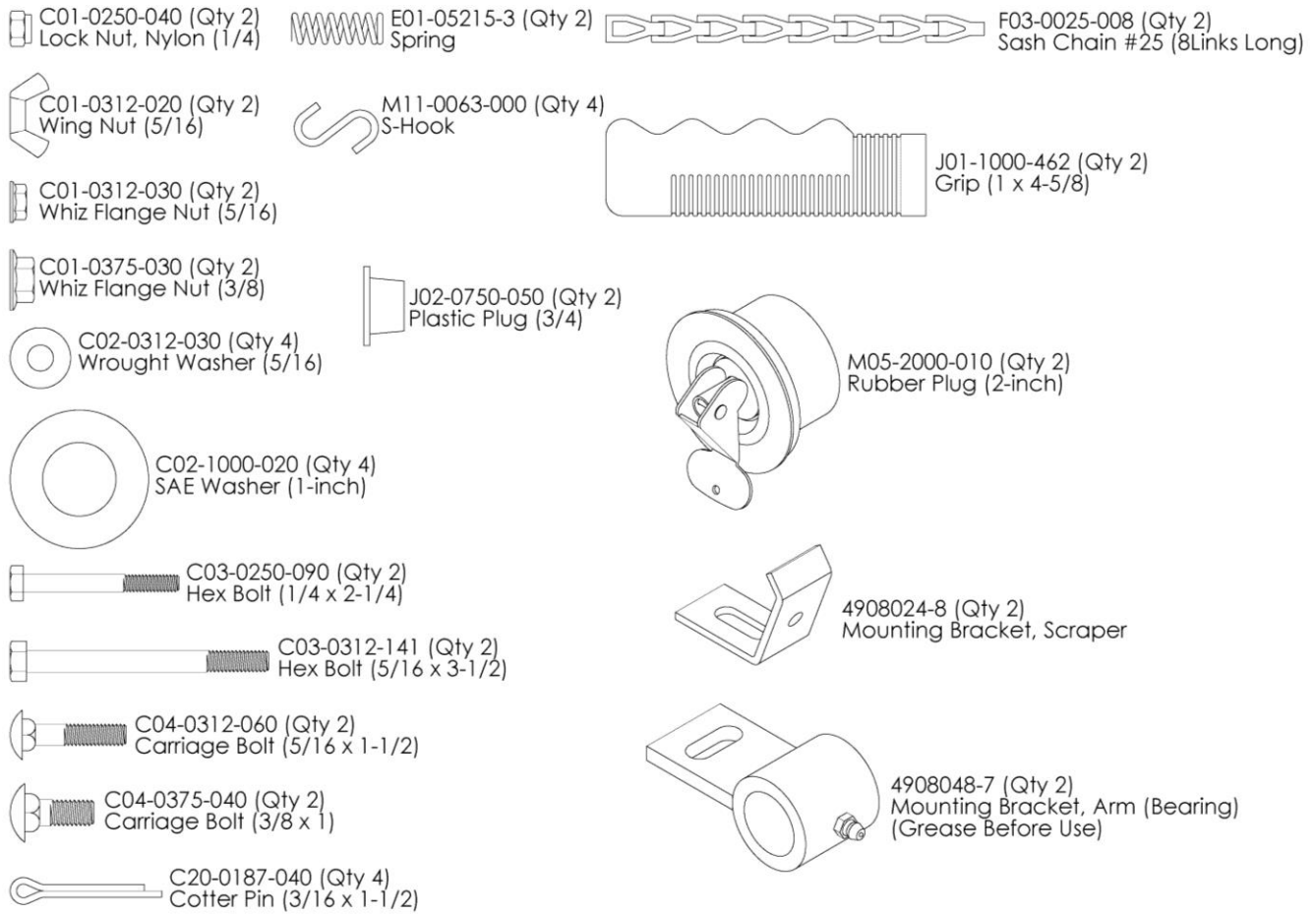

Assembly Instructions (See diagrams on following pages.)

1. Attach bearings (4908048-7) to axle on roller using two 1-inch washers (one each side of bearing) and two 3/16 x 1-1/2 cotter pins. Secure cotter pins. **Note:** On both ends of roller with hole, align eye of cotter pins so they are closest to the hole. This will be used in step #9.
Grease bearings now before use. Note: Failure to do so will result in damage to axle shaft.
2. Push one grip (J01-1000-462) on each end of the hitch-handle as shown.
3. Insert plastic plug (J02-0750-050) into end of each mounting arms (4908048-4).
4. Attach both mounting arms (4908048-4) to hitch-handle (4908024-5) using the two 5/16 x 3-1/2 hex bolts, 5/16 washers and 5/16 wing nuts as shown. Do not tighten leave loose until step #5.
5. Attach flat end of mounting arms (assembled to hitch-handle) to bearings (assembled in step #1) using the 3/8 x 1 carriage bolts and whiz flange nuts as shown. Do not tighten leave loose. Tighten wing nuts holding hitch/handle to mounting arms. Center mounting arms hitch-handle on roller. Before tightening carriage bolts on bearings and mounting arms, center bearing between 1-inch washers and tighten whiz flange nuts securely.
Repeat of other side.
6. Attach one scraper mounting bracket (4908024-8) to each end of scraper angle (4908048-6) using the 1/4 x 2-1/4 hex bolts, springs (E01-05215-3) and 1/4 nylon lock nuts as shown. Tighten nylon lock nut so the 1/4 bolt protrudes out of the lock nut about 1/8-inch.
7. Attach scraper assembly (step #6) to mounting arms as shown using the two 5/16 x 1-1/2 carriage bolts and 5/16 whiz flange nuts. Do not tighten. Adjust scraper to leave a slight clearance from roller. Check clearance all the way around roller to be sure scraper is not rubbing on roller. Tighten carriage bolts securely.
8. Assemble S-hook to one end of sash chain as shown. Insert other end of S-hook into hole in rubber plug snap flange (M05-2000-010) as shown. Clinch both ends of the S-hook to secure sash chain to rubber plug.
Repeat step for other rubber plug.
9. Insert other S-hook into inner most cotter pin assembled to roller axle (Step #1) as shown. Insert rubber plug into hole on roller, ensuring that length of sash chain is as desired for easy fit. Connect end of sash chain to S-hook. Adjust S-hook position if necessary and clinch both ends of S-hook to secure rubber plug to axle.
Repeat step for other rubber plug.
10. If bearings were not greased in Step#1 do so now. **Failure to do so will result in damage to axle shaft.**
11. To convert hitch-handle from tractor hitch to pull type handle. Remove both wings nut and bolts as shown. Flip hitch-handle over so pull type handle is to the front. Replace bolts, washers and wing nuts and tighten securely. **Note:** If bolt is not easily removed from hitch-handle, one or both of the carriage bolts fastening the mounting arms to the bearings will have to be loosened to pivot handle.
Remember to securely retighten all hardware.

Operation & Storage (Please read the following for proper use and storage.)

Grease fittings on each bearing before use and every hour during prolonged use. 3 MPH max travel speed.

Check all bolts for tightness after first two hours of use; check periodically thereafter.

Do not cross rocky areas, gravel drive ways or paved areas as large or small rocks will dent or could puncture roller.

Drain water before transport or storage. Leave rubber plug out over storage so any small amounts of water will evaporate. Water will freeze over winter and can damage roller beyond repair.

Assembly Diagrams

Step #1

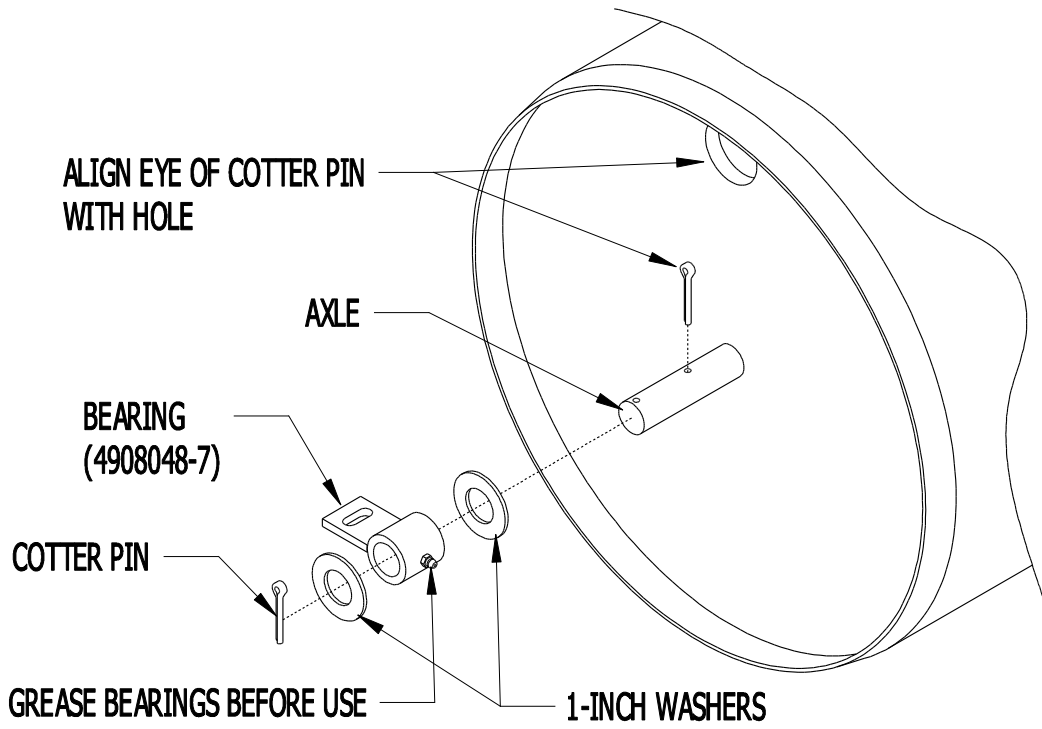

Step #2

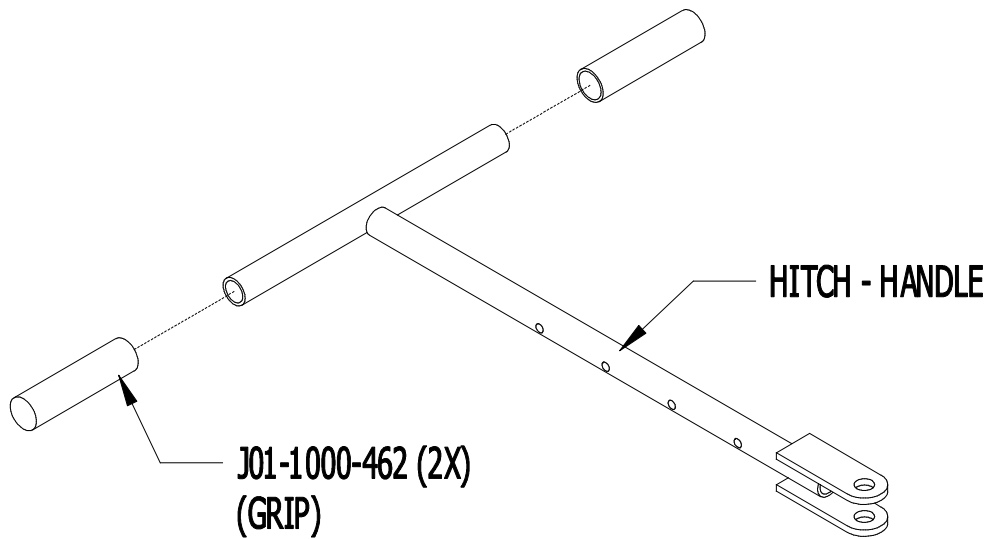

Step #3

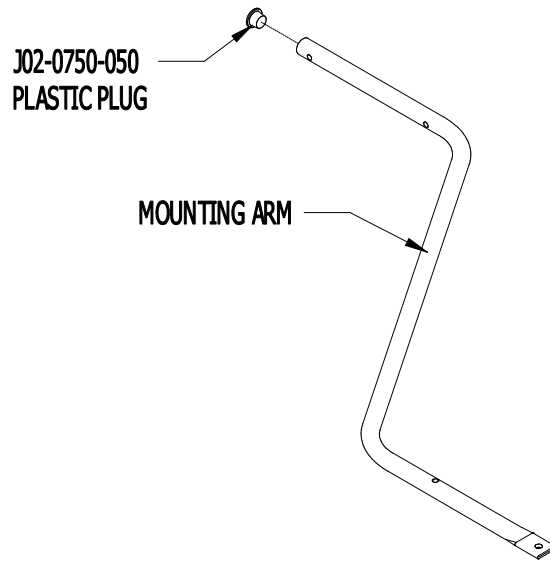

Step #4

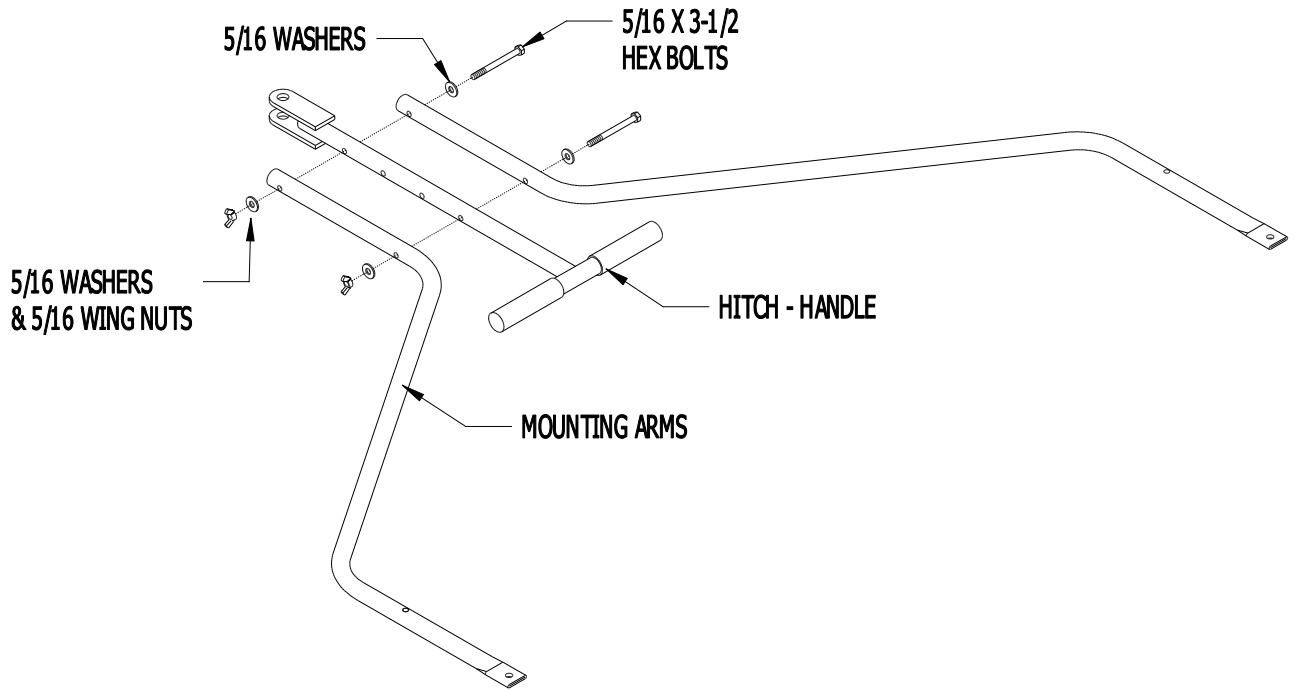

Step #5

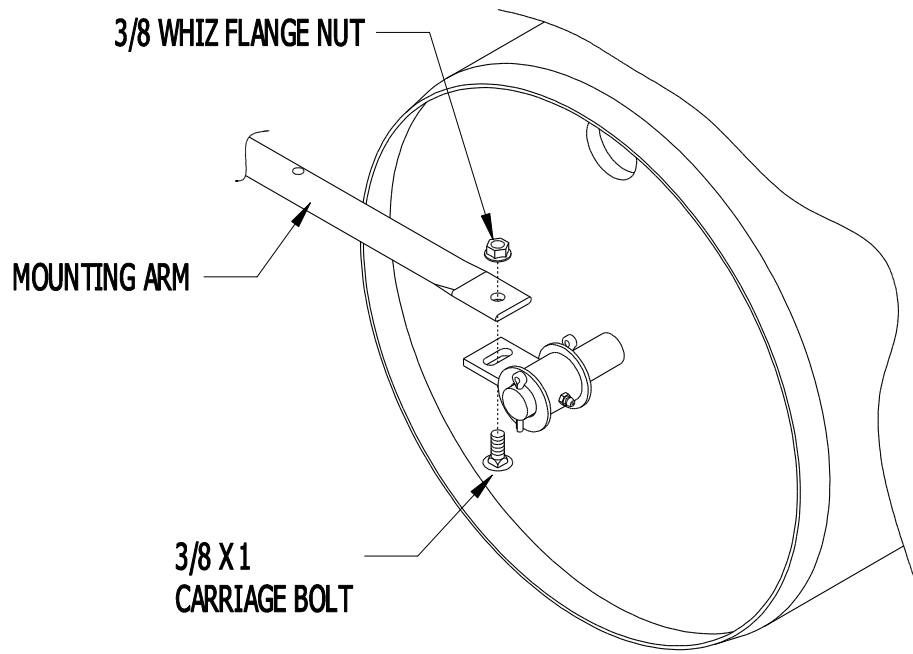

Step #6

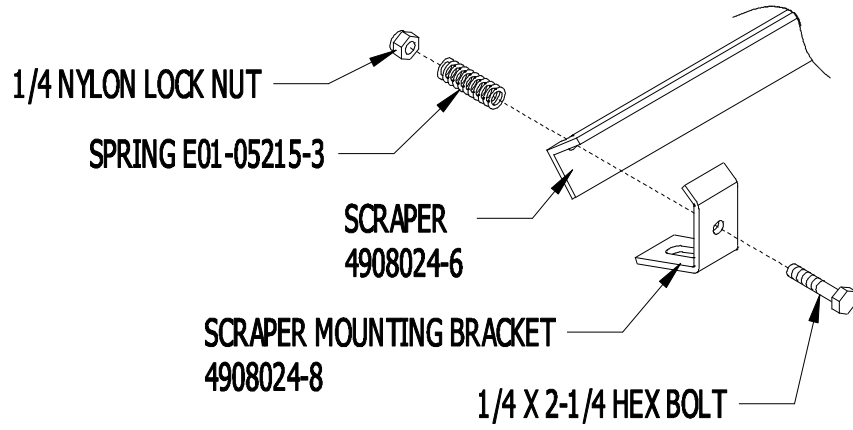

Step #7

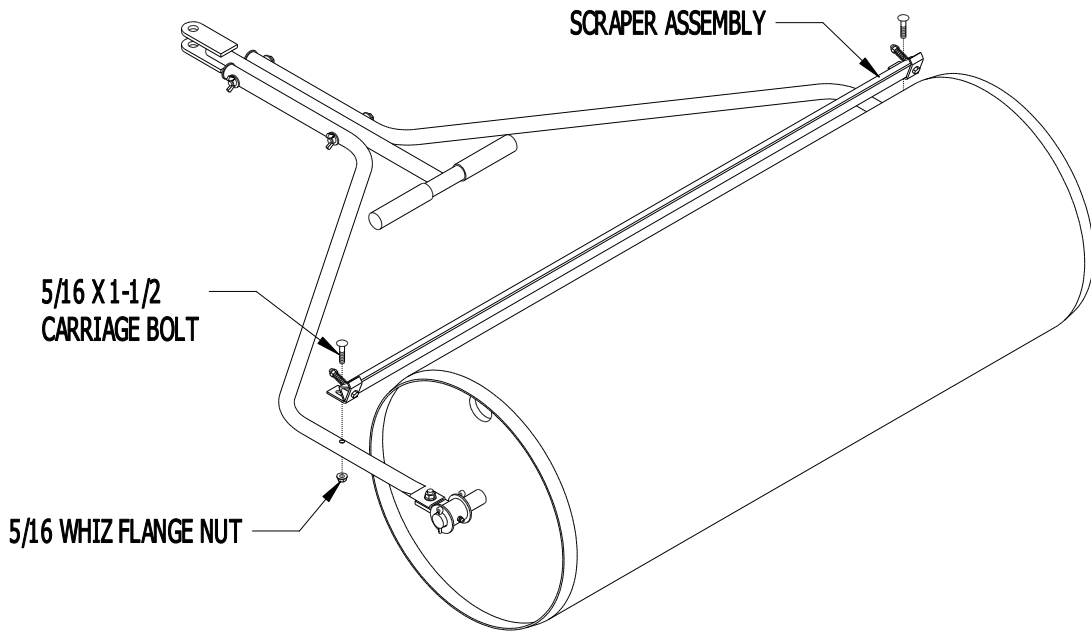

Step #8

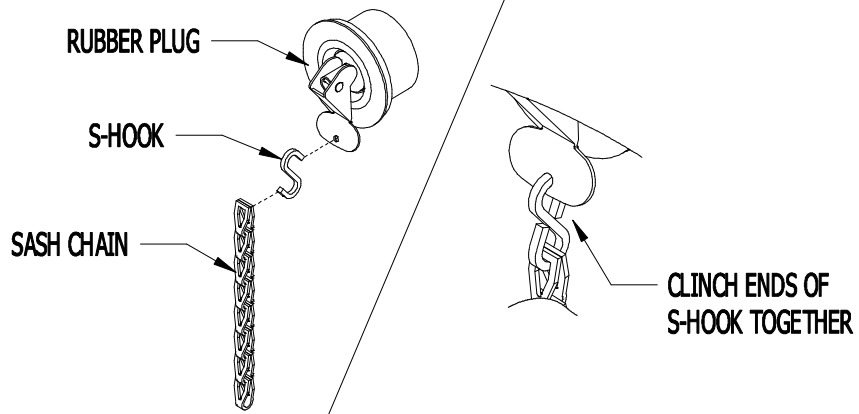

Step #9

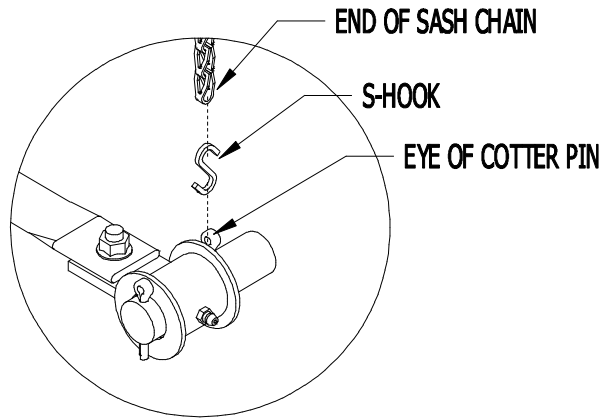

Step #10

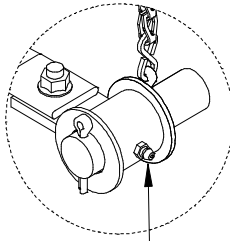

**GREASE BEARINGS BEFORE USE
BOTH SIDES**

**FAILURE TO DO SO WILL RESULT
IN DAMAGE TO AXLE SHAFT**

Step #11 Hitch-Handle Conversion

HITCH

**REMOVE WING NUTS,
WASHERS & BOLTS**

**CARRIAGE BOLT MAY NEED
TO BE LOOSENED**

HANDLE

**REMOVE WING NUTS,
WASHERS & BOLTS**

**CARRIAGE BOLT MAY NEED
TO BE LOOSENED**

18 x 48 Roller Schematic

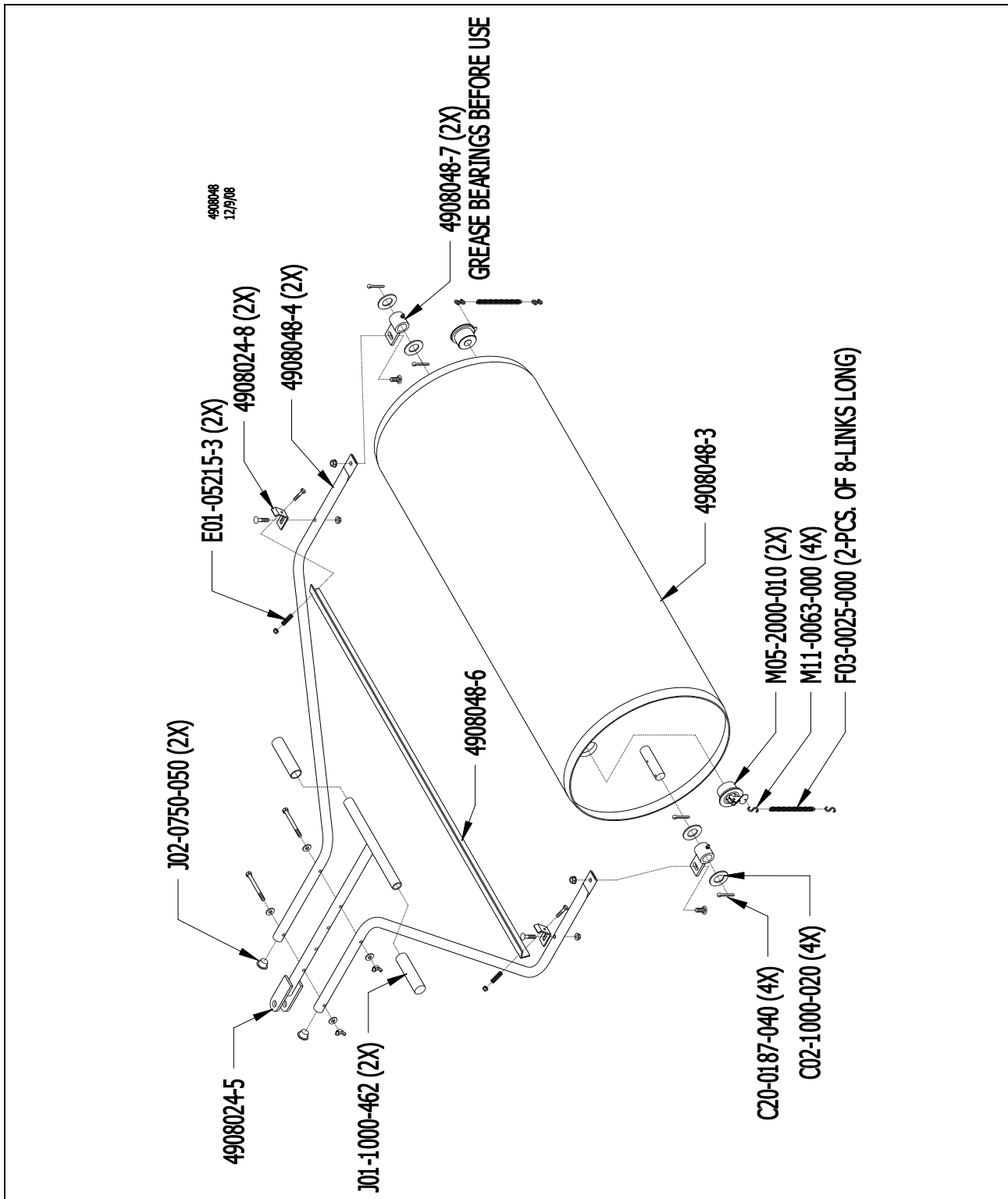

GDY-4908048-PPL
 Drawings 4908048-B, 49H8048, 4908048-A, 4908048
 December 2, 2013
 Revised From (6/29/12)
 Printed in the USA