



# Illustrated Parts & Packing List

815 Rice Lake Street, Owatonna, MN 55060

For a complete distributor & dealer list go to [www.gandy.net](http://www.gandy.net)

## 490892 Sweep Master

(All Hardware in Place Unless Otherwise Specified)

- 8..... M13-0024-000.....Brush (Packaged 8 to a Carton)  
Use: 24 Hex Bolt (1/4 x 1-1/4) (C03-0250-051) **(In Hardware Bag)**  
4 Hex Bolt (1/4 x 1-1/2) (C03-0250-061) **(In Hardware Bag)**  
28 Lock Washer (1/4) (C02-0250-010) **(In Hardware Bag)**
- 1..... 490892-A.....Plate Carton Containing:**
  - 1 ..... 490892-1.....Brush Plate, Sweep Master  
Use: 1 Decal, Sweep Master (N02-0049-002)
  - 2 ..... 490892-2.....Parallel Angles (Mounted In Place)  
Use: 8 Hex Bolt (3/8 x 1) (C03-0375-041)  
8 Serrated Hex Flange Lock Nut (3/8) (C01-0375-031)
  - 1 ..... 490892-3.....Cross Member, Center (Mounted In Place)  
Use: 4 Hex Bolt (3/8 x 1) (C03-0375-041)  
4 Serrated Hex Flange Lock Nut (3/8) (C01-0375-031)
  - 2 ..... 490892-4.....Cross Member, Outer (Mounted In Place) **(See Note)**  
Use: 4 Hex Bolt (3/8 x 1-1/2) (C03-0375-061) **(See Note)**  
4 Lock Nut, Nylon (3/8) (C01-0375-041) **(See Note)**
- 1 ..... 490892-H .....Hardware Bag: (Hardware Bag Fastened to Parallel Angle)**
  - 28..... C02-0250-010.....Lock Washer (1/4)
  - 24..... C03-0250-051.....Hex Bolt (1/4 x 1-1/4)
  - 4..... C03-0250-061.....Hex Bolt (1/4 x 1-1/2)

**Note:** Bolts and lock nuts attaching outer cross members to parallel angles are in place and are to be kept loose to allow flexing of the brush plate.

## Gandy Sweep Master 490892 Assembly Instructions

1. Lay Brush Plate with assembled parallel angles and cross members on flat work area.
2. Attach each of the (8) synthetic brushes to the underside of the Brush Plate at the outside angles and along both diagonals. Use one 1/4 x 1-1/4 hex bolt and lock washer at each and two of each at the center of each brush, except at the outside of each outer cross member where two 1/4 x 1-1/2 hex bolts are used. Use one lock washer on each bolt. Tighten securely. Note: Center two brushes have three bolts holding them in place.
3. Before using, set brushes to minimize jumping.  
This can be achieved by dragging the Sweep Master on a hard surface for five to ten minutes.

**Note:** Bolts and lock nuts attaching outer cross members to parallel angles are in place and are to be kept loose to allow flexing of the brush plate.

### Brush Plate Assembly (Assembled At Factory)

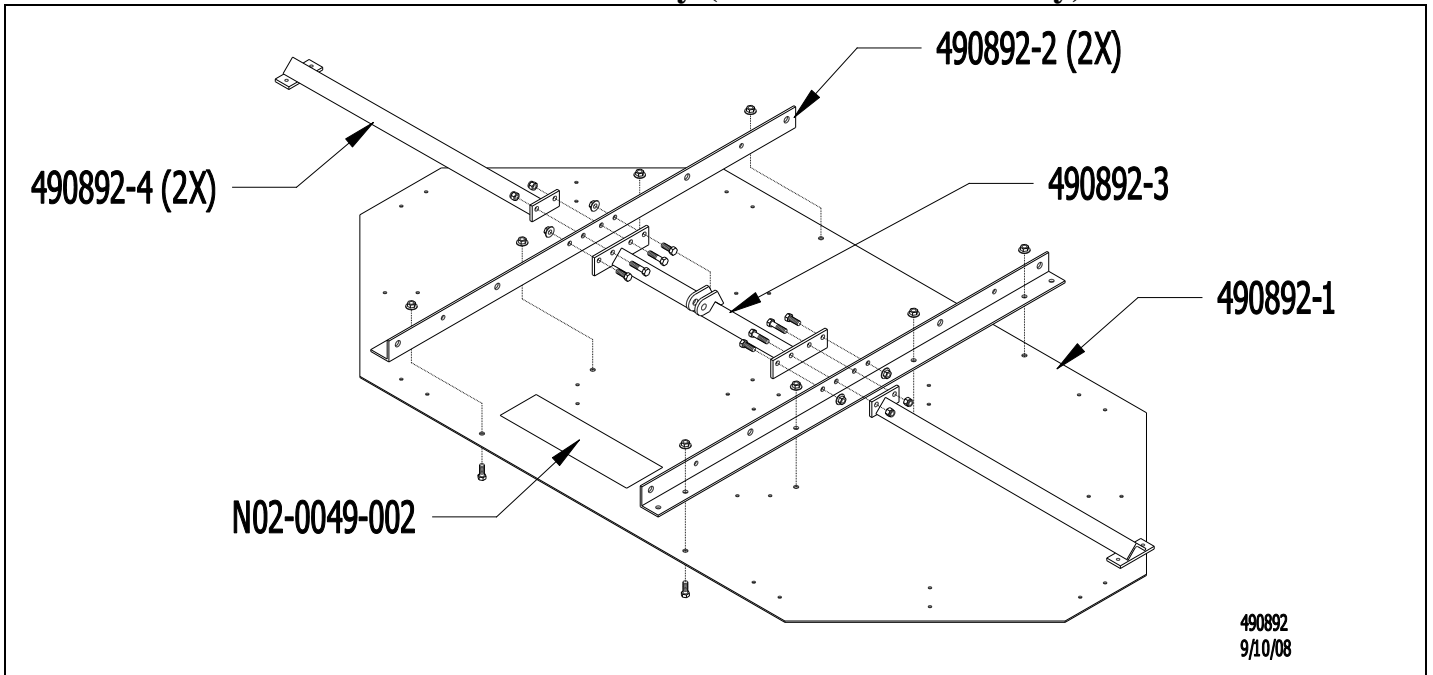

### Brush Assembly

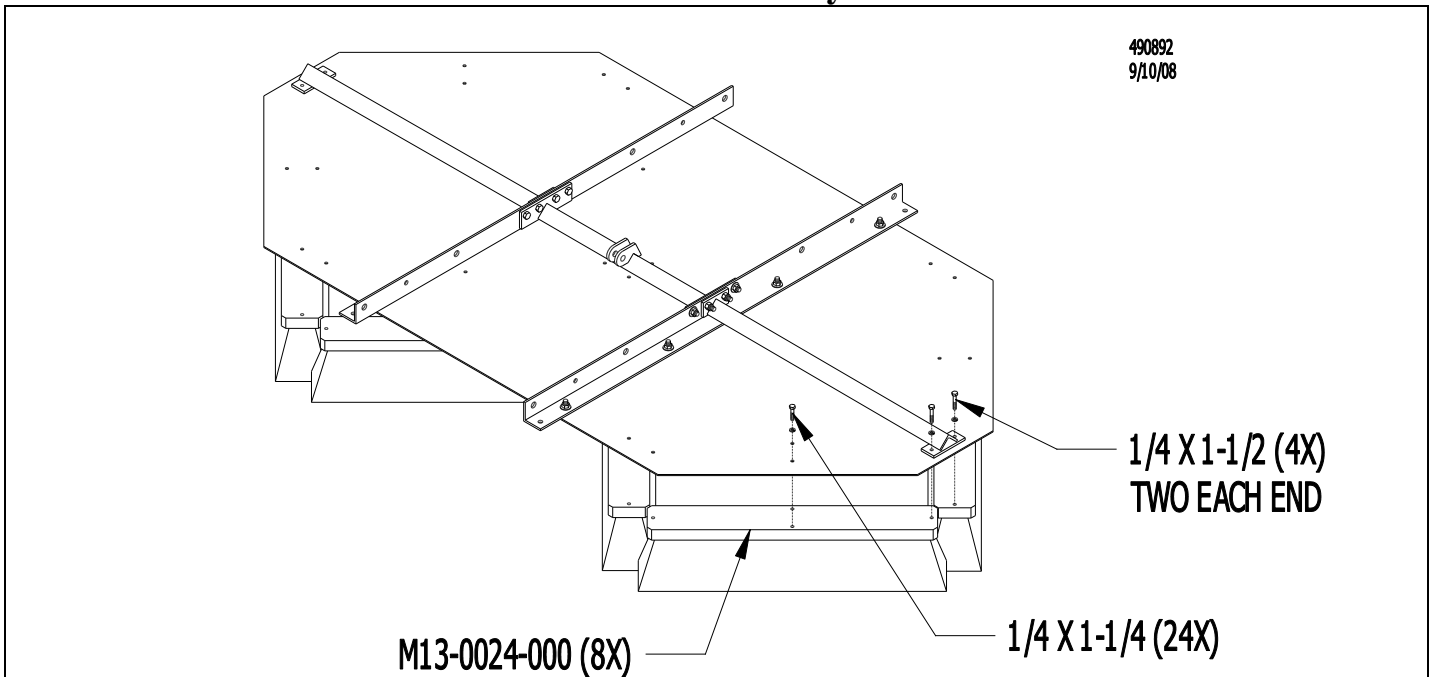

GDY-490892-PPL  
Drawing: 490892  
January 16, 2013  
Revised From (8/19/09)  
(490892) mw  
Printed in the USA