



# Illustrated Parts & Packing List

815 Rice Lake Street, Owatonna, MN 55060

Phone: 800-443-2476 / 507-451-5430

www.gandy.net / Email: sales@gandy.net

## **P451WP12** **45 LB Capacity Cam Gauge Applicator** **1-outlet, 12-Volt Motor Drive** **For Feed Additives & Hay Preservatives**

### **Carton Containing the Following Items: (See Page #2)**

- 1 ..... P45 Hopper Assemble, 2-Outlet, w/12-Volt Electric Motor & Chain Guard Installed
- 1 ..... P45 Hopper Cover
- 1 ..... 0906128-9 ..... Angle, Hopper Mount
- 2 ..... 09201 ..... Suspender Mount Left & Right
- 1 ..... 09202 ..... Suspender Plate
- 1 ..... P45WP12-H ..... Hardware Bag (See Below For Contents)
- 1 ..... 09075589-A ..... Wire Bag (See Below For Contents)
- 1 ..... Packet

### **Hardware Bag (P45WP12-H) Containing the Following: (See Page #3)**

- 1 ..... C01-0164-040 ..... Kep Nut (#8-32)
- 2 ..... C01-0500-010 ..... Hex Nut (1/2)
- 2 ..... C02-0500-010 ..... Lock Washer (1/2)
- 2 ..... C03-0500-062 ..... Hex Bolt (1/2 x 1-1/2)
- 1 ..... C07-0164-051 ..... Pan Head Mach Screw (#8-32 x 3/8)
- 6 ..... C07-0187-080 ..... Pan Head Stainless Mach Screw (#10-24 x 5/8)
- 2 ..... C21-0072-020 ..... Hair Pin Cotter (.08 x 1-9/16)
- 4 ..... E09-06137 ..... Spring Clip
- 3 ..... J02-0687-074 ..... Red Cap (11/16 I.D. x 3/4)
- 2 ..... M05-0000-008 ..... Rubber Latch & Keeper

### **Wire Bag (09075589-A) Containing the Following: (See Page #3)**

- 1 ..... L03-0003-000 ..... Molded Connector (16ga x 8-inch)
- 4 ..... L03-0005-000 ..... Wire Connector, Blue (18 to 14ga)
- 2 ..... L04-0001-000 ..... Cable Tie (3/16 x 8)
- 1 ..... L05-0001-000 ..... Switch, Push-Pull
- 1 ..... 09071589-11 ..... Power Wire, Red (8-Ft Long)
- 1 ..... 09073589-9 ..... Bracket Switch Mount
- 1 ..... 09082589-31 ..... Molded Connector (8-inch w/Fork Terminal, 16ga)
- 1 ..... 09084589-33 ..... Electric Rip Core, 23-Ft (Red-Brown 16ga)

## Contents of Carton

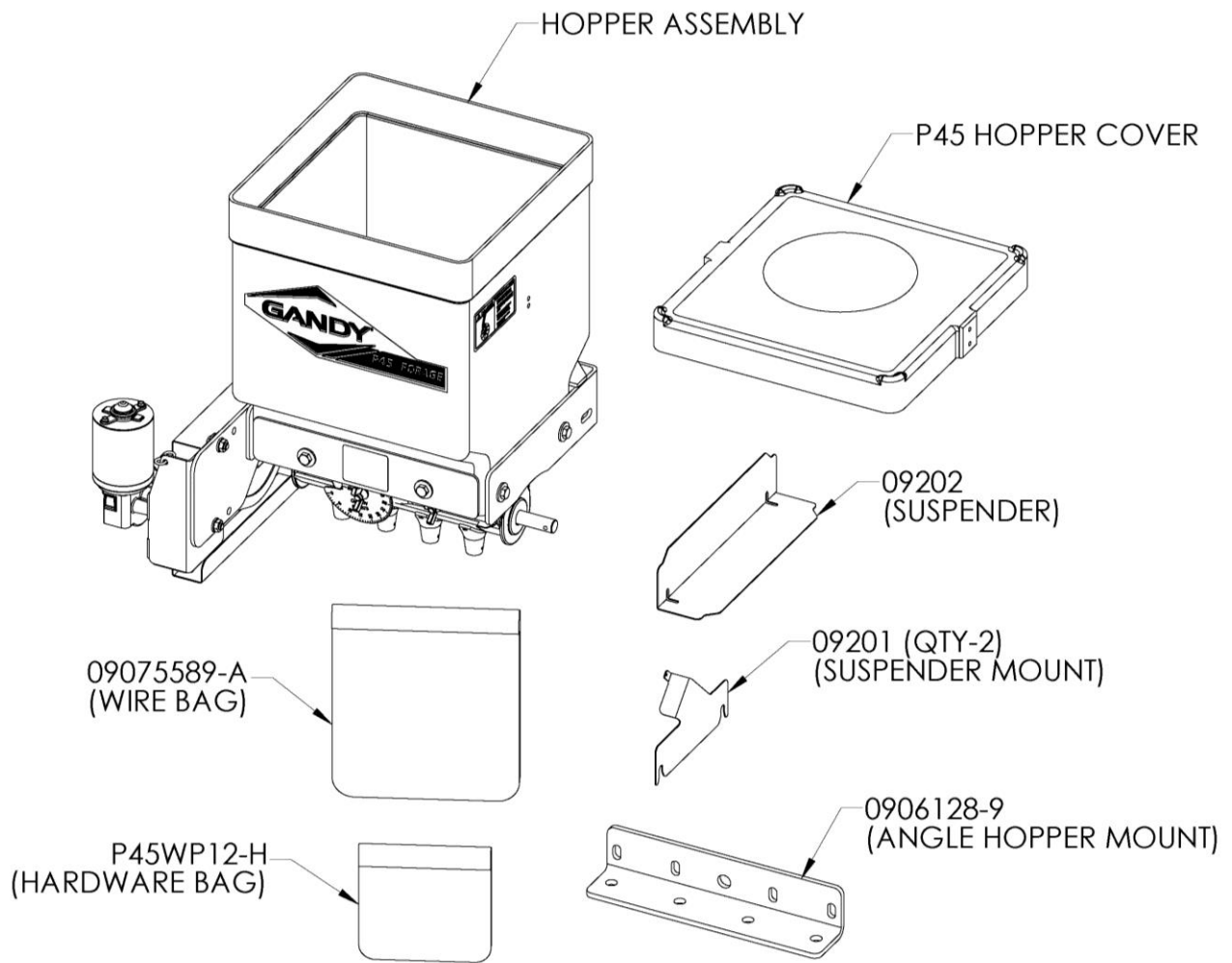

### Contents of Hardware Bag P45WP12-H

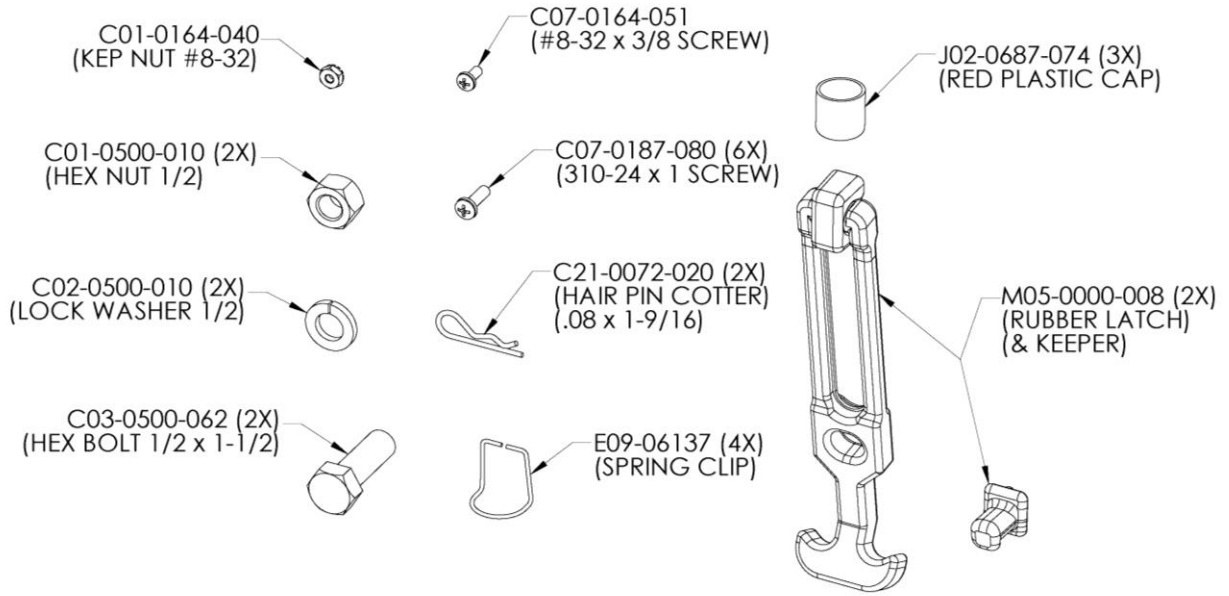

### Contents of Wire Bag 09075589-A

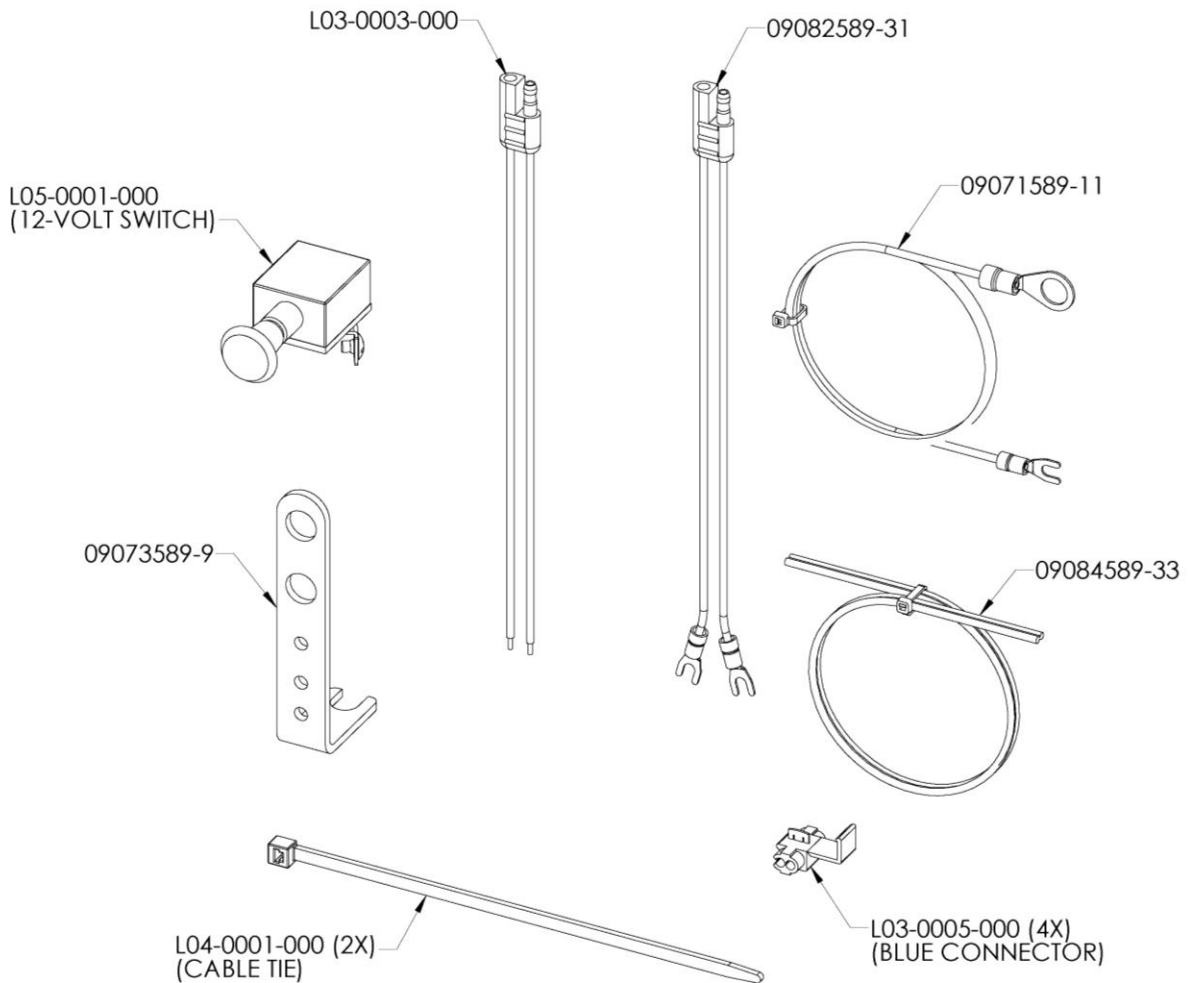

## Complete Parts Break Down:

### 1..... Hopper Assemble, Poly Cam Gauge 1-Outlet, Straight Spouts, 12-Volt Electric Motor & Chain Guard (All Parts & Hardware in Place Unless Otherwise Specified)

1.....	M10-0001-300.....	P45 Hopper Body & Cover (45 Lb. Capacity)
		Use: 2 Decal, P45 Forage (N02-0001-110)
		2 Decal, Rotating Parts Inside (N02-0001-108)
		(P45 Hopper Replacement Cover Part #M10-0001-301)
1.....	M10-0001-302.....	Bottom Insert P45 (Silver)
1.....	09200.....	Support Plate, Poly Cam Gauge
1.....	M05-0030-006.....	Gasket, Bottom Cam Poly Hopper
2.....	09099926-7.....	Bottom Support Plate
		Use: 4 Hex Bolt (5/16 x 3/4 Stainless) (C03-0312-031)
		4 Wrought Washer (5/16) (C02-0312-030)
1.....	09099926-6.....	U-Frame, Poly Hopper
		Use: 2 Hex Bolt (5/16 x 1 Stainless) (C03-0312-045)
		2 Wrought Washer (5/16) (C02-0312-030)
2.....	09080821-5.....	Hanger Strap
		Use: 4 Lock Nut, Nylon (1/4) (C01-0250-040)
1.....	09099926-1C1.....	Bottom & Slide, 1-Outlet, Straight Spout
		Use: 2 Wing Nut (5/16) (C01-0312-020)
		2 SAE Washer (5/16) (C02-0312-020)
		2 Whiz Flange Nut (3/16) (C01-0187-030)
		2 Nylon Washer (1/4) (C02-0250-011)
		1 Rear Hanger, Slide (09072637)
		1 Lock Strip (09072638)
		1 Cam Gauge (0906375)
		1 Spout, Straight (0908012-6)
		2 Rivet (C17-0281-050)
1.....	09069508.....	Rotor Bar, Rubber, 8-inch
		Use: 2 O-Ring (K03-0562-000)
		2 Washer, Stainless (09073507-7)
		4 Sponge Washer (1-1/2 x 5/16 x 5/8 I.D.) (C02-0625-051)
		2 Rotor Bar Spacer (09099926-11)
2.....	M05-0664-401.....	Gasket
2.....	090693.....	Bearing
2.....	09081826.....	Bearing Retainer
		Use: 2 Whiz Flange Nut (3/16) (C01-0187-030)

Continued on next page....

- 1 ..... 09099926-8.....Motor Mount Bracket, 12-Volt Motor
  - Use: 2 Hex Bolt (5/16 x 1-1/4 Stainless) (C03-0312-052)
  - 2 Wrought Washer (5/16) (C02-0312-030)
- 1 ..... 09075589-4.....Electric Motor Assembly, 12-Volt, 1/64 HP, 4 Amp
  - Use: 1 Super Flange Nut (1/4-24) (Replacement Part) (C01-0250-031)
  - 1 Sprocket, 8-Tooth (Replacement Part) (G01-0008-010)
  - 1 Decal, Electric Motor 12-Volt (N02-0009-050)
  - 3 Pan Head Mach Screw (1/4-28 x 1/2) (C07-0250-070)
  - 3 Shake Proof Washer (#1114) (C02-0250-040)
- 1 ..... 09077589-3.....Motor Mount, Electric Motor
  - Use: 2 Whiz Flange Nut (1/4) (C01-0250-030)-(Part of 09077589-3)
  - 1 S-Hook (#63) (M11-0063-000)
  - 1 Cable Tie w/ Eye (1/8 x 5) (L04-0002-000)
  - 1 Decal, EM Caution (N02-0009-052)
  - 2 Hex Bolt (5/16 x 3/4 Stainless) (C03-0312-031)
  - 2 Wrought Washer (5/16) (C02-0312-030)
  - 2 Whiz Flange Nut (5/16) (C01-0312-030)
- 1 ..... N02-0009-053 .....Decal, EM Arrow Rotation (in Place on Sprocket)
- 1 ..... 09099927-16.....Sprocket, 32-Tooth
  - Use: 1 Hairpin Cotter (.177 x 3-3/4) (C21-0177-020)
- 1 ..... F02-0041-051 .....Roller Chain #41 (51-Rollers Complete)
- 1 ..... 09099926-10.....Chain Guard

**The Following Parts are shipped unassembled in Carton:**

- 1 ..... P45 Hopper Cover
- 2 ..... 09201 .....Suspender Mount Left & Right (For P45 Hopper)
- 1 ..... 09202 .....Suspender Plate (For P45 Hopper)
  - Use: 2 Hair Pin Cotter (.08 x 1-9/16) (C21-0072-020) **(in Hardware Bag)**
- 1 ..... 0906128-9.....Angle, Hopper Mount
  - Use: 2 Hex Bolt (1/2 x 1-1/2) (C03-0500-062) **(in Hardware Bag)**
  - 2 Lock Washer (1/2) (C02-0500-010) **(in Hardware Bag)**
  - 2 Hex Nut (1/2) (C01-0500-010) **(in Hardware Bag)**

# Hopper Assembly Parts Schematic

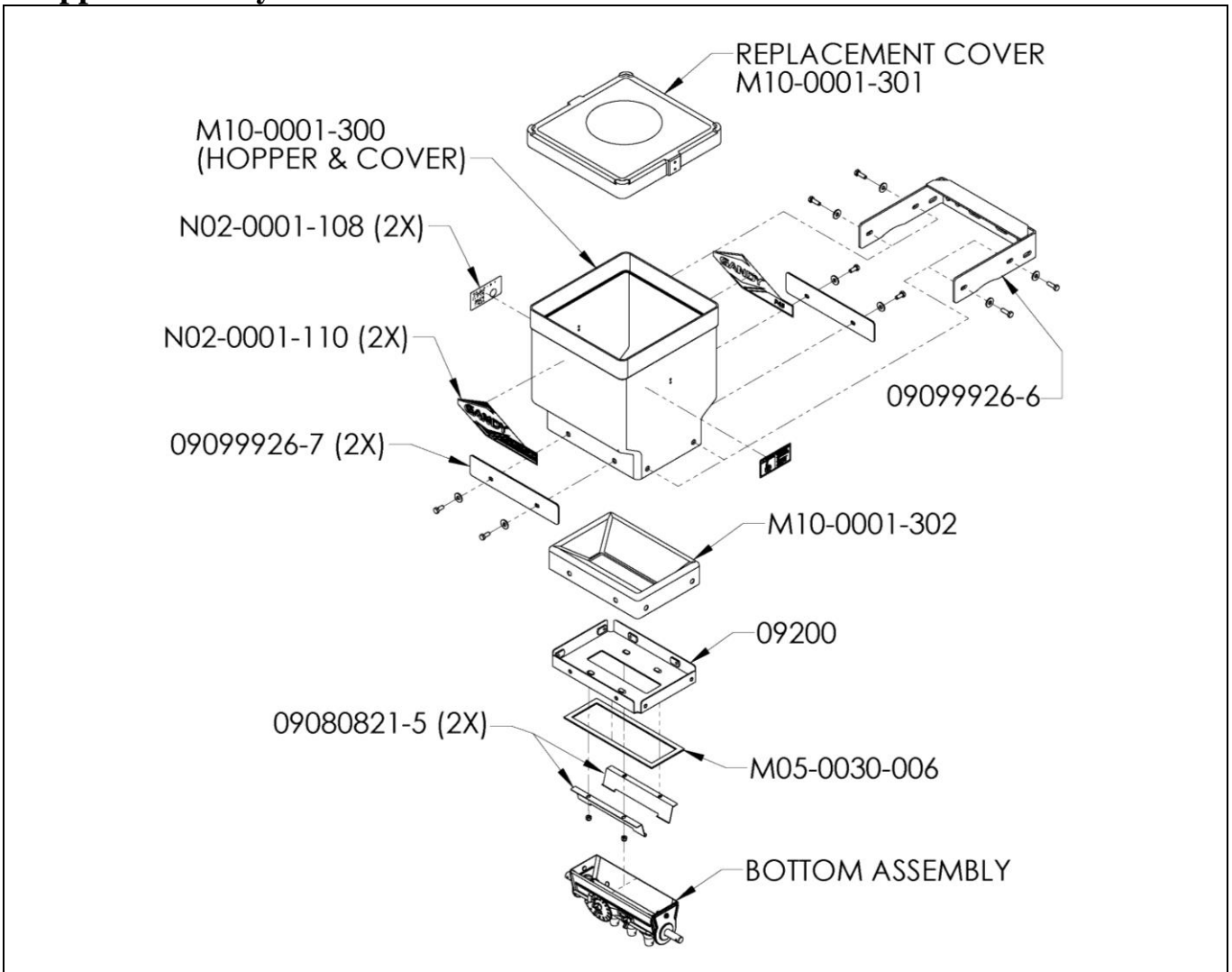

# Bottom & Rotor Bar Parts Schematic

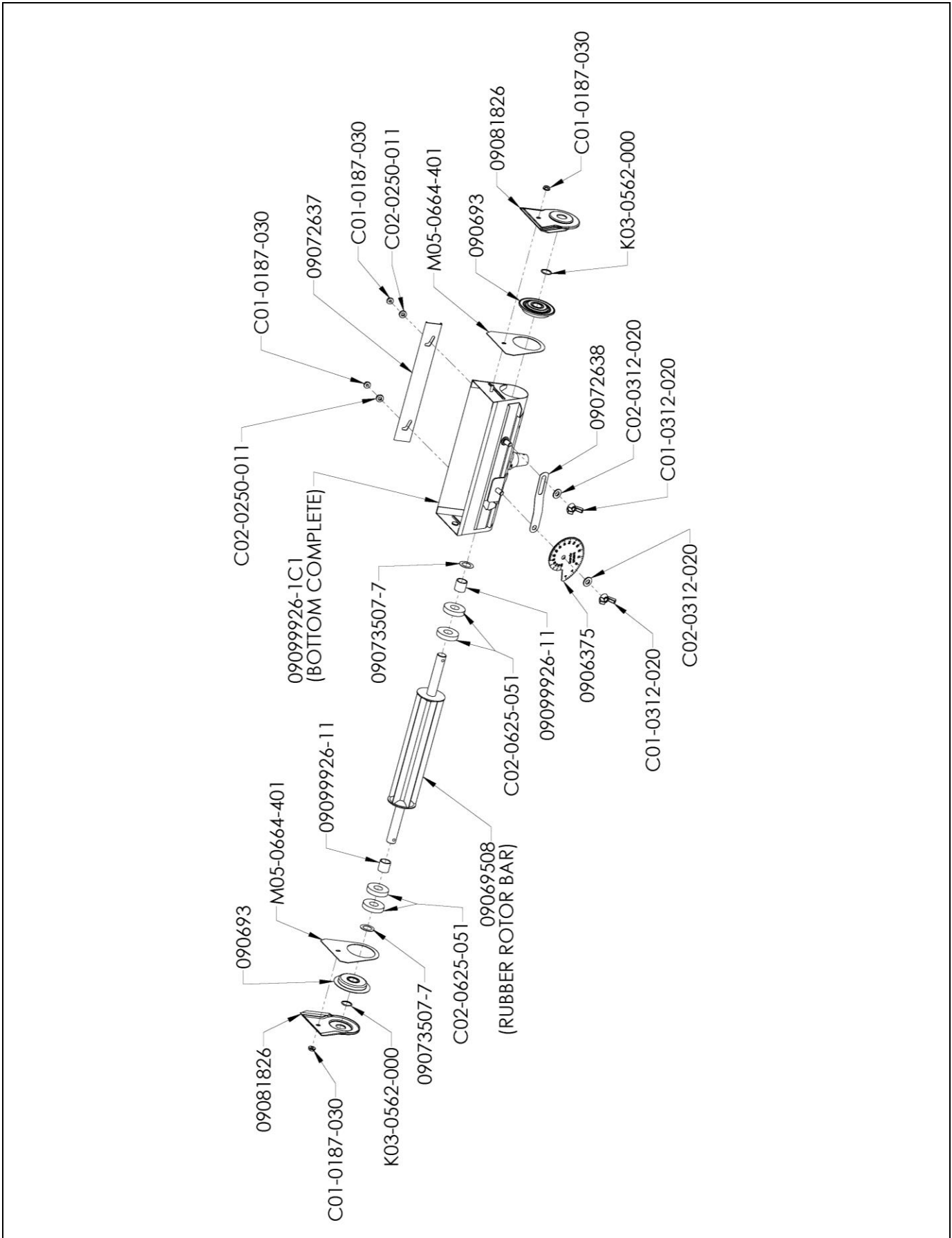

# Electric Motor Mounting & Parts Schematic

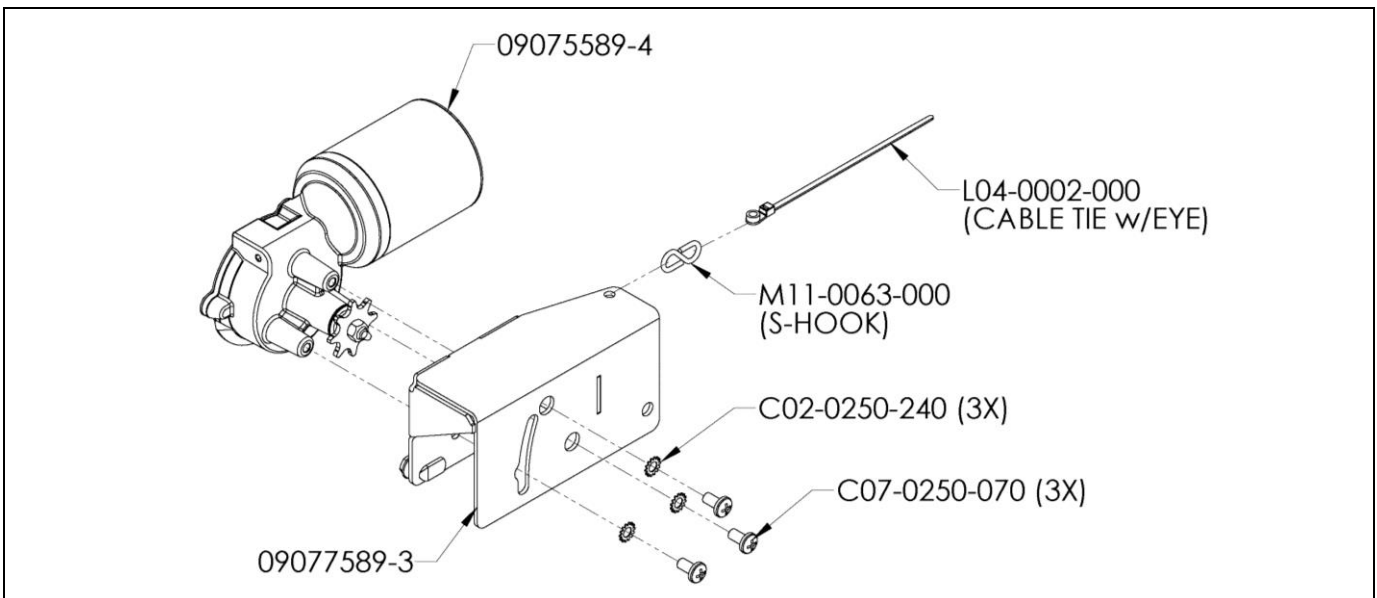
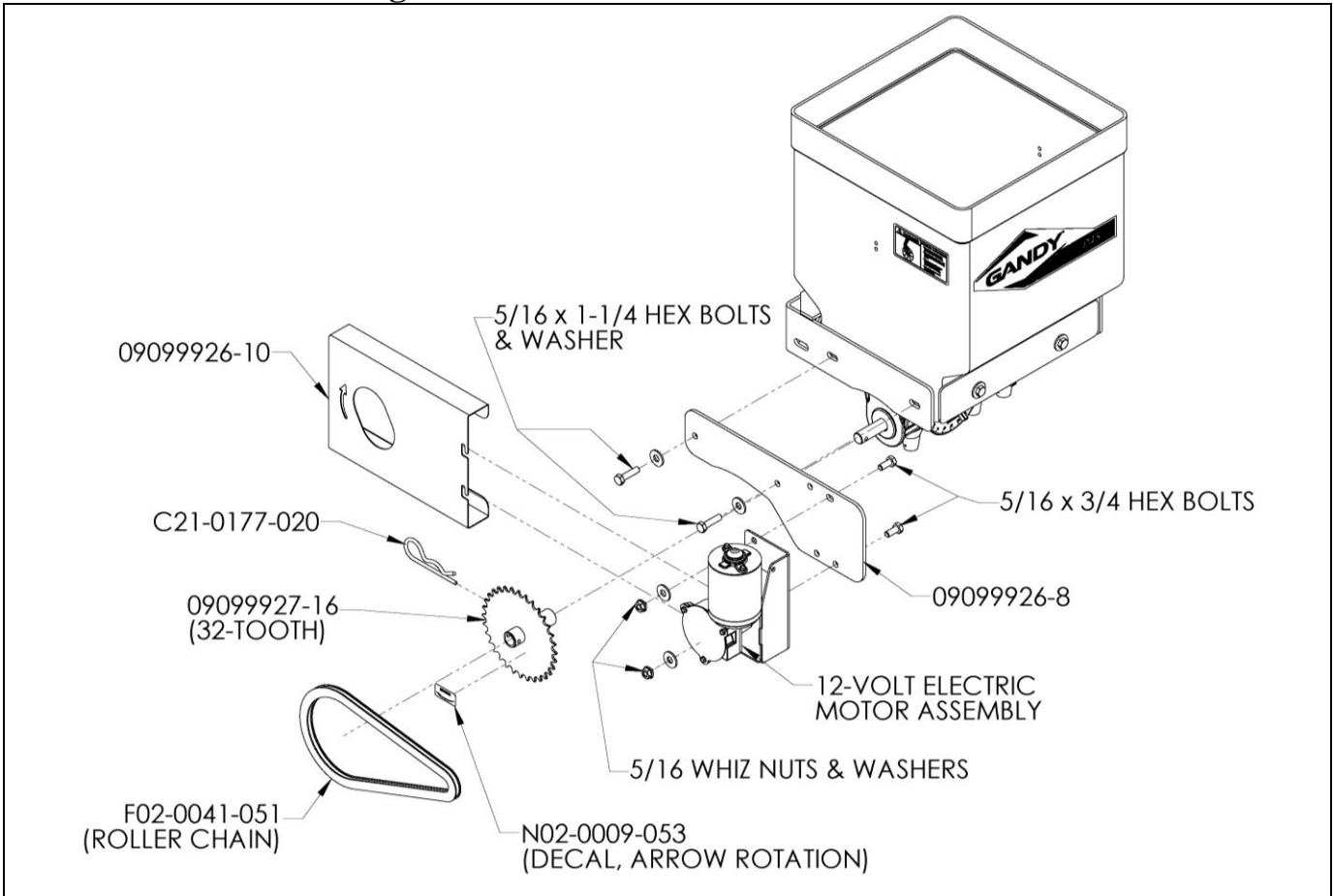

**12-Volt electric motor wiring: Green (+) / Black (-).**  
**(NOTE: Screws & Shake Proof Washers are a part of electric motor.)**



## Cover / Rubber Latch Assembly

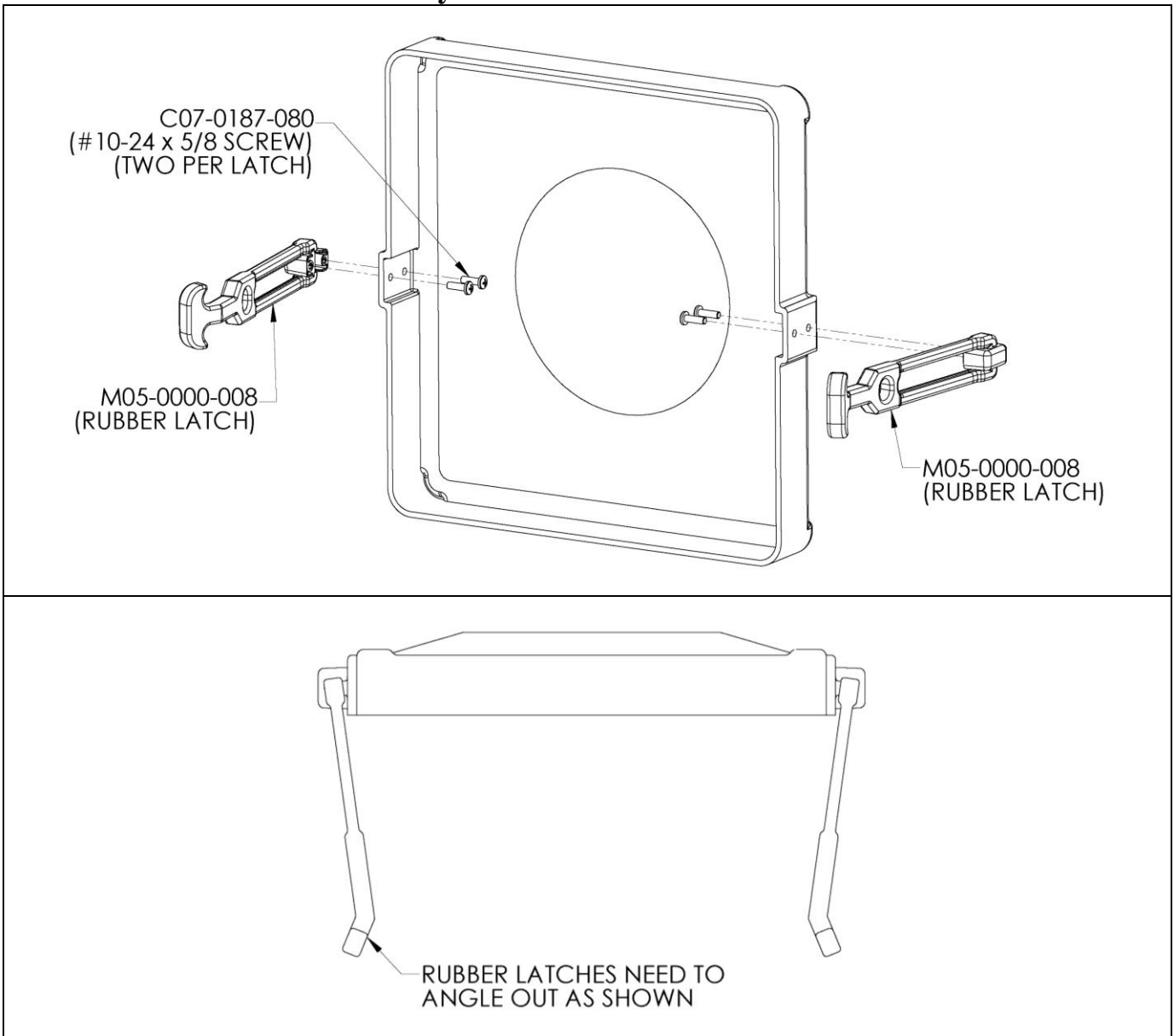

Assemble both rubber latches to the two holes on the side of the poly hopper cover using the #10-24 x 5/8 screws (C07-0187-080) as shown.

## Hopper / Latch Keeper Assembly

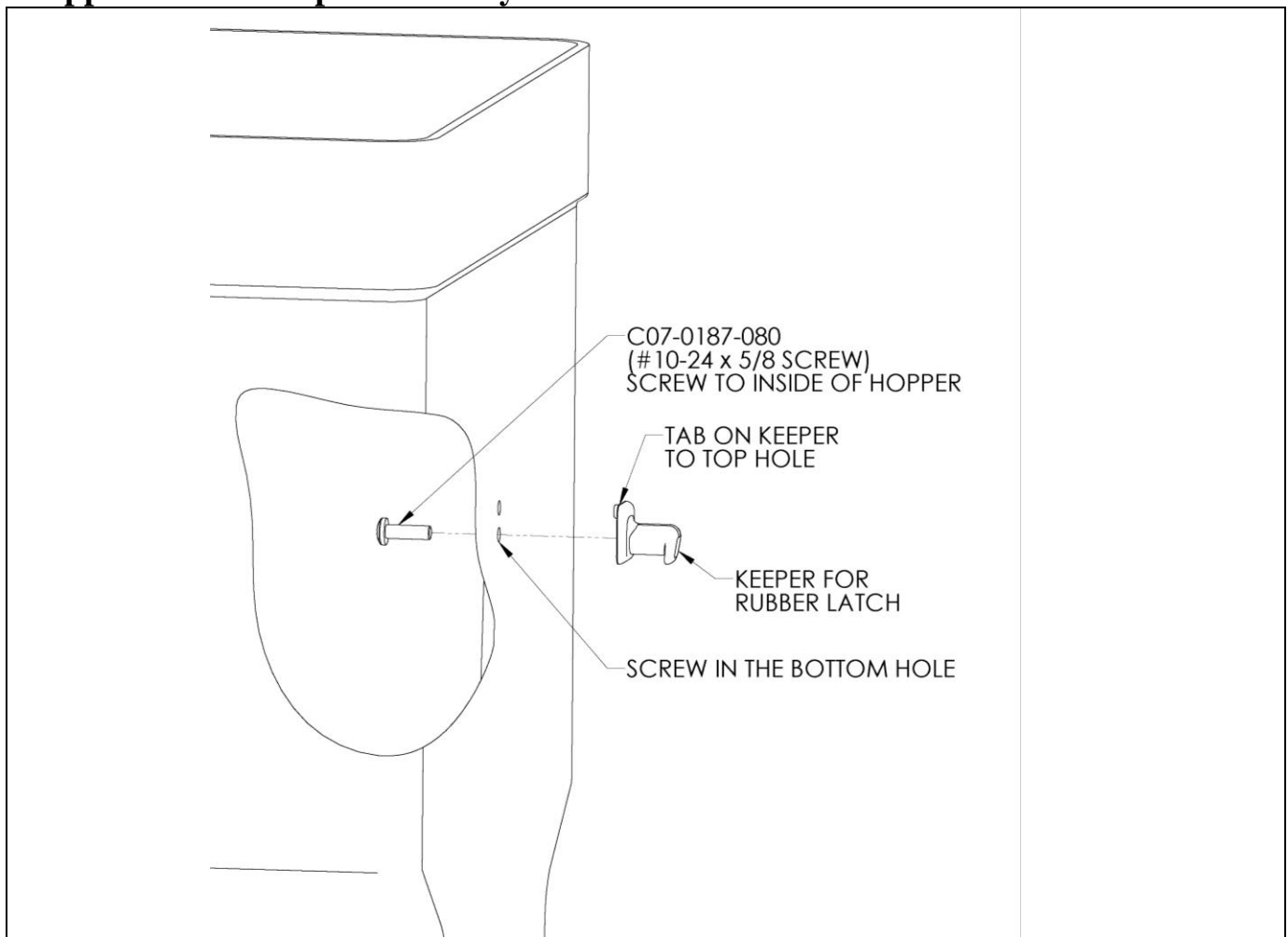

Assemble rubber latch keeper to the two holes on the side of the poly hopper using one #10-24 x 5/8 screw (C07-0187-080) as shown. Repeat for the second keeper on the other side of hopper.

## Hopper Angle Mount Installation

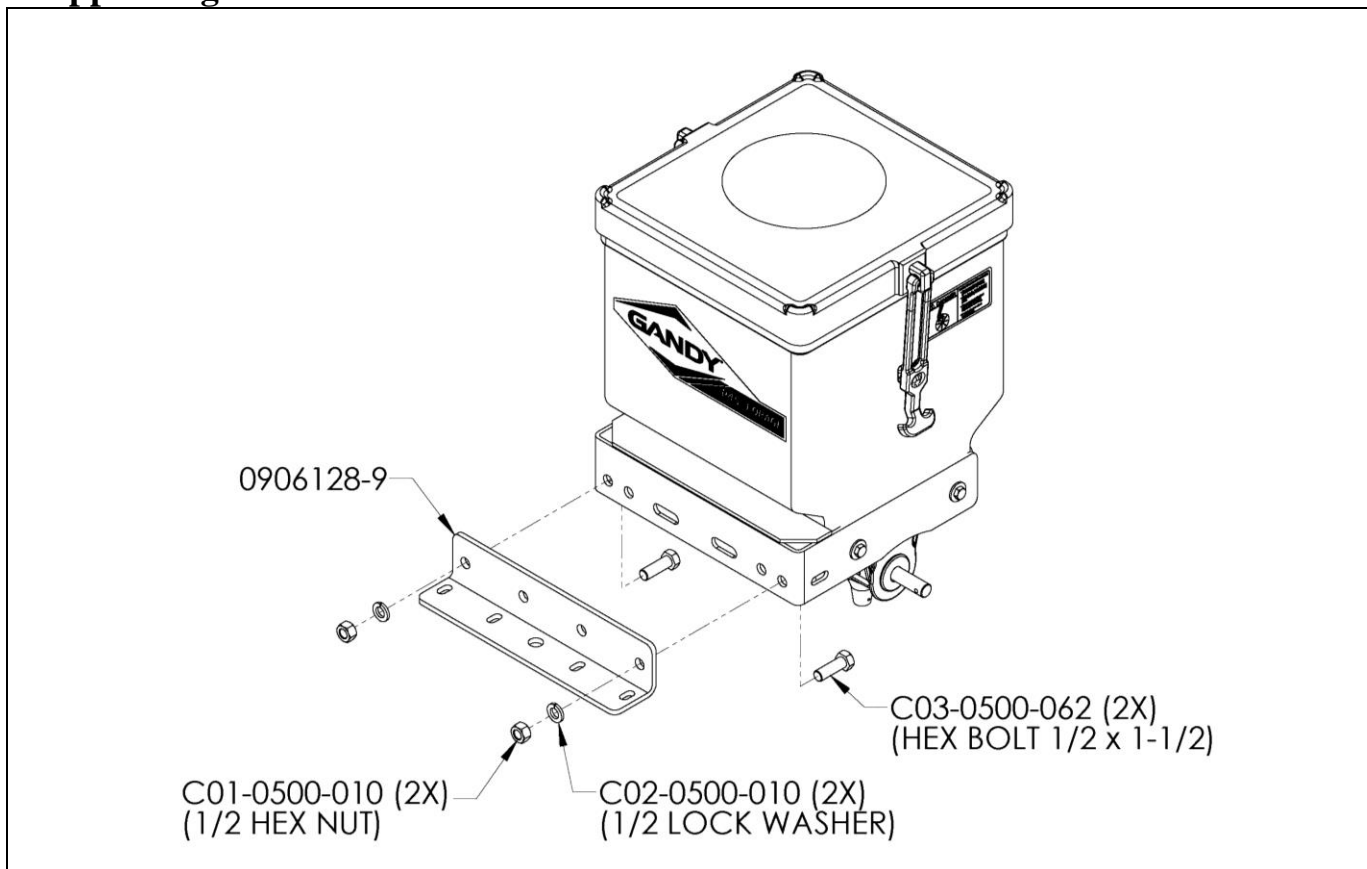

## Suspender Installation

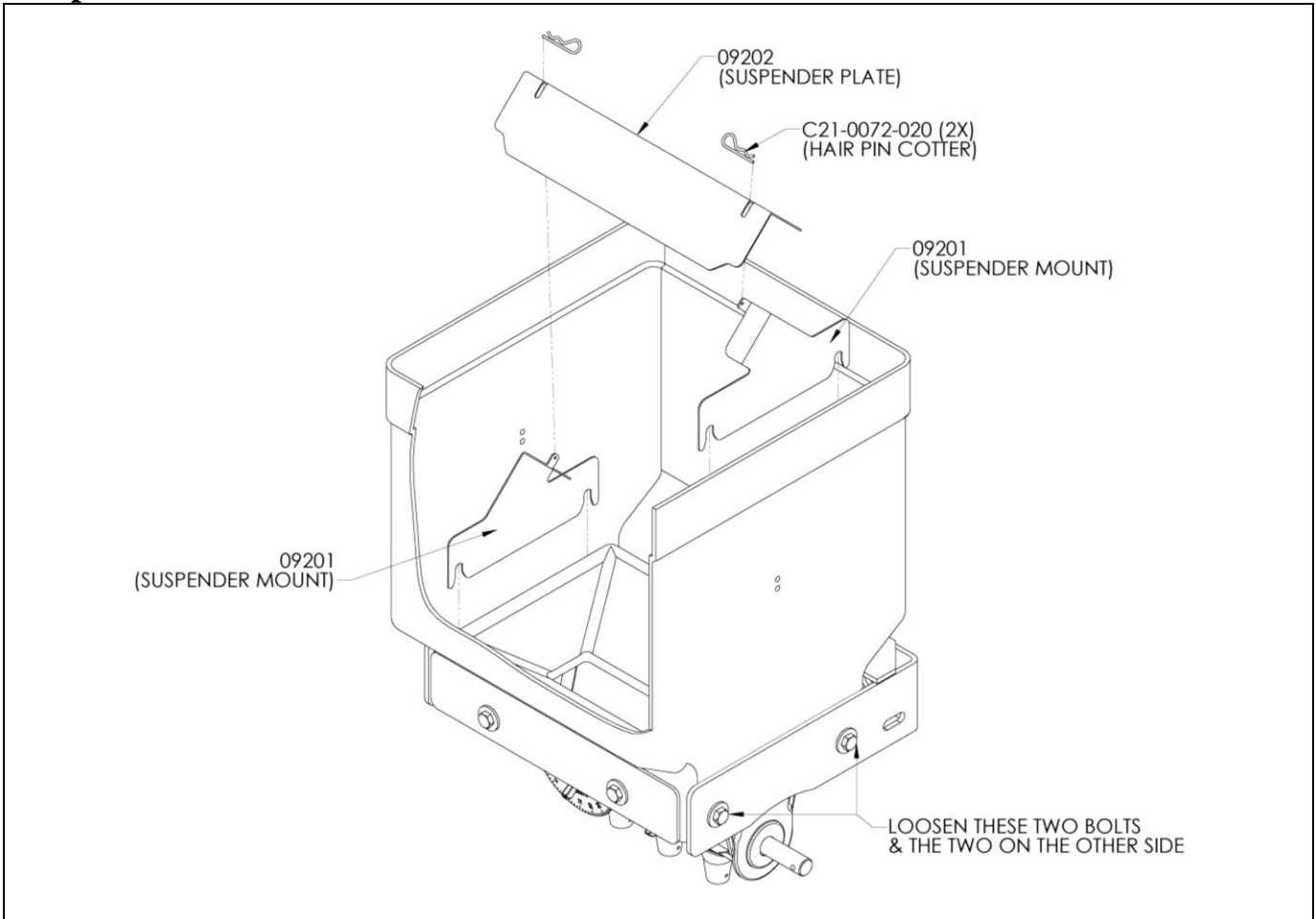

Loosen the bolts shown in diagram above. Locate suspender mounts (09201) and push insert mount down between hopper and bottom insert (silver in color) until it bottoms out on the two bolts that were loosened. Repeat for other mount. Tighten the two bolts on each side securely. Place suspender plate (09202) on top of the mounts. Secure in place using the two hair pin cotters supplied in the hardware bag.

Red caps and spring clips that are supplied in the hardware bag are used to close off outlets that are not needed. Push red cap onto spout and secure using the spring clip. Push ends of spring clip through red cap and into holes on both sides of spout.

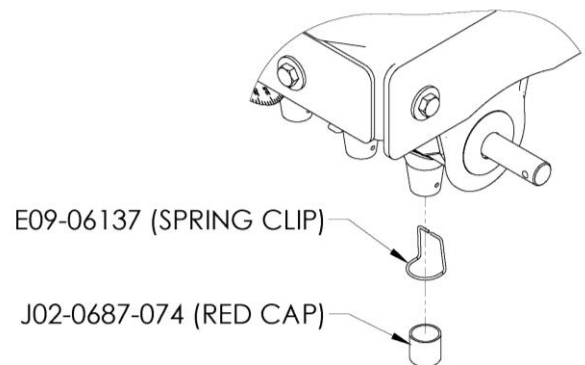

# Wiring Diagram

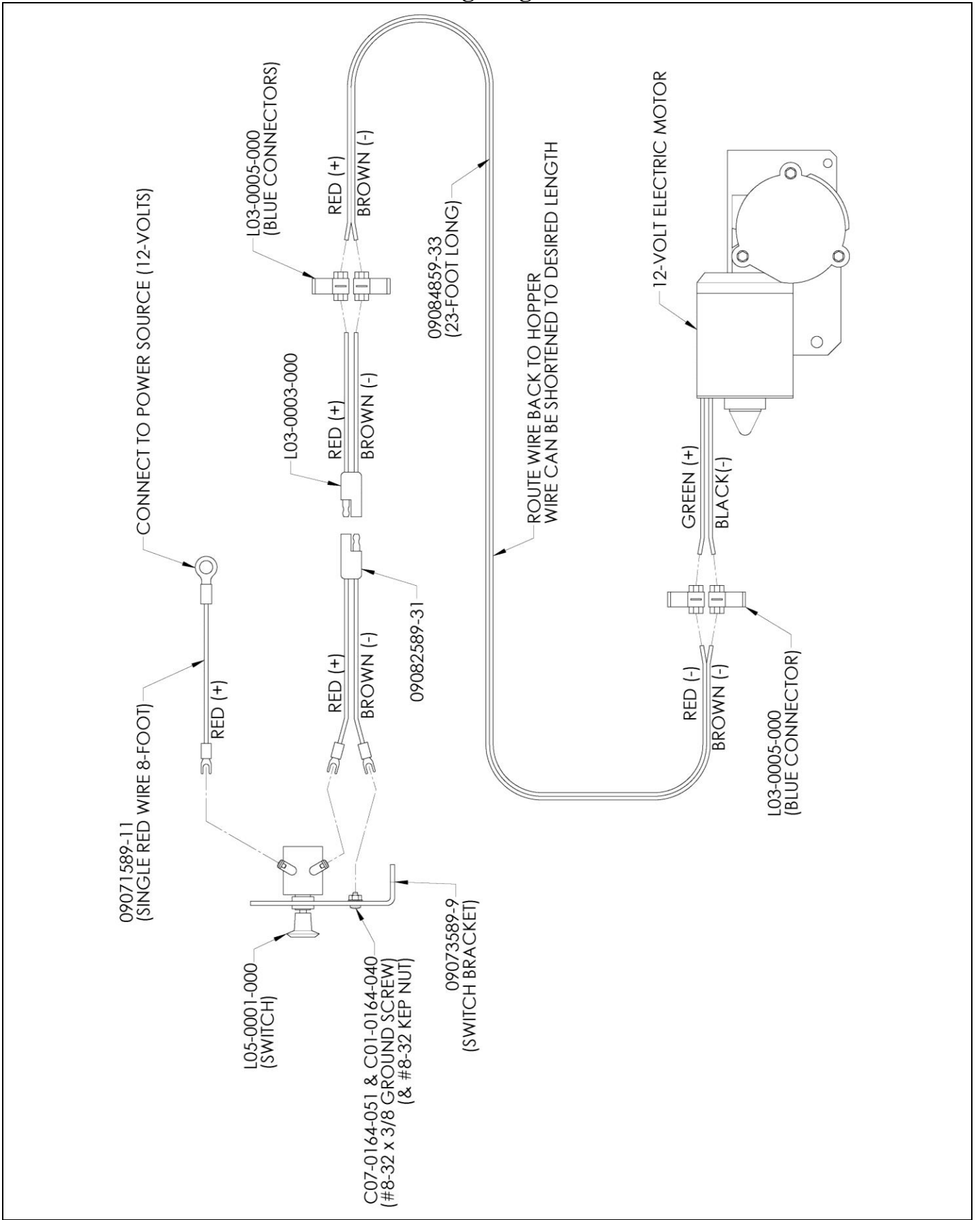

## Wiring Instructions (See Wiring Diagram)

1. Attach switch-mounting bracket (09073589-9) in a convenient location in the tractor operator's area.  
**Note:** Ground wire connects back to switch bracket. Switch mounting bracket needs to make good metal-to-metal contact to achieve this or motor will not run. If a good ground cannot be achieved you will have to run a wire from the switch bracket back to the frame or negative terminal on battery.
2. Fasten switch (L05-0001-000) to switch mounting bracket and tighten in place.  
Connect #8-32 screw (C07-0164-051) to switch mounting bracket using the #8-32 kep nut (C01-0164-040) as shown. Do not tighten. This is the ground screw. (See Wiring Diagram)
3. Attach ring terminal end of 8-foot red wire (09071589-11) to desired power source, such as live terminal on ignition switch or battery. Be sure you have 12-volts of current. Attach other end to either terminal on switch. (See Wiring Diagram)
4. Connect molded connector (Male end with fork terminals) (09082589-31) to switch as follows. Connect the red wire (positive) to terminal on switch. Connect brown wire (negative) to #8-32 ground screw. Tighten connections securely. (See Wiring Diagram)
5. String wire from switch back to motor following wiring diagram as shown. Fasten wires together using the eight blue wire connectors. If you do not need full length of wire, cut off excess to keep voltage drop to a minimum. Secure wires in place when done being sure wires cannot be pinched, cut or pulled apart.
6. Check that the motor turns in the proper direction.  
The 8-tooth sprocket on the motor should turn counterclockwise.  
The drive shaft should turn 15-20 rpm using the 8-32 tooth sprocket ratio with the hopper empty.
7. Be sure hoppers are clean and free of foreign objects before using.

## Operating Instruction:

**IMPORTANT!** Road travel with hoppers filled can cause compaction of some chemicals. This compaction can make it difficult for the motor to start. Therefore, try to fill hoppers just before use at the field.

1. Pull the switch mounted by the operator's seat at the beginning of each row to start the electric motor and metering shaft turning.

Push the switch at the end of each row to stop the motor and metering shaft.

**Note: The motor will run hot under normal load.**

2. Remove chemical at the end of each day so that you start with fresh materials.
3. If chemical has been left in hopper overnight, disconnect the drive by pulling the hairpin cotters and turn each rotor by hand a revolution or so. Using only a hairpin cotter as a lever, you should have to exert only moderate to light effort to turn the rotor. If much force is required to turn rotor, either the chemical has gotten wet, the bearings are gummed up, or both. Clean the hopper or free the bearings before starting to plant. (When reassembling the hopper, use only your fingers to tighten the wing nuts that hold the bearing retainers in place.)

If hopper is not freed-up, it will put more strain on the electric motor.

## General Information

### A. Power Requirement

Under normal load with two hoppers, each motor will draw between 2 and 3 amps. Under adverse conditions, the load will increase up to 5 amps. If the usage increases about 5 amps, one or both of the following steps should be tacking to reduce the power usage and prolong the life of the motor.

Check that the bearings are clean and the rotor is free turning.

### B. Rotor Speed

If you are applying a high rate of chemical requiring a gauge setting of 60 to 80, some minor pulsation in the flow of granules may be apparent. This means that the rotor is not turning fast enough. If the rotors turn easily or you are driving only 1 to 2 hoppers per motor, you can replace the 32T with a 24T sprocket, and thus increase the rotor speed.

GDY-P451WP12-PPL

Drawings: P454WP12-PACKAGE, P45WP12-H, 09075589-A, P45WP-ASY, P45B1RST, P4512VOLT, P45ELEC12VOLT, P45-COVER-ASY, P45-K-ASY, P45-ANGLE, P45-SUSP, P45-CAP, P45WP12-WA

October 10, 2013  
Printed in the USA