



Illustrated Parts & Packing List

815 Rice Lake Street, Owatonna, MN 55060

For a complete distributor & dealer list go to www.gandy.net

P452-R 45 LB Capacity Cam Gauge Applicator 2-outlet, Straight Spouts, Rubber Rotor Bar

Carton Containing the Following Items:

- 1 P45 Hopper Assemble, 2-Outlet Rubber Rotor Bar, Straight Spouts
- 1 P45 Hopper Cover
- 1 P45H..... Hardware Bag (See Below For Contents)
- 1 Packet

Hardware Bag (P45H) Containing the Following:

- 6 C07-0187-080..... Pan Head Stainless Mach Screw (#10-24 x 5/8)
- 4 E09-06137 Spring Clip
- 3 J02-0687-074..... Red Cap (11/16 I.D. x 3/4)
- 2 M05-0000-008..... Rubber Latch & Keeper

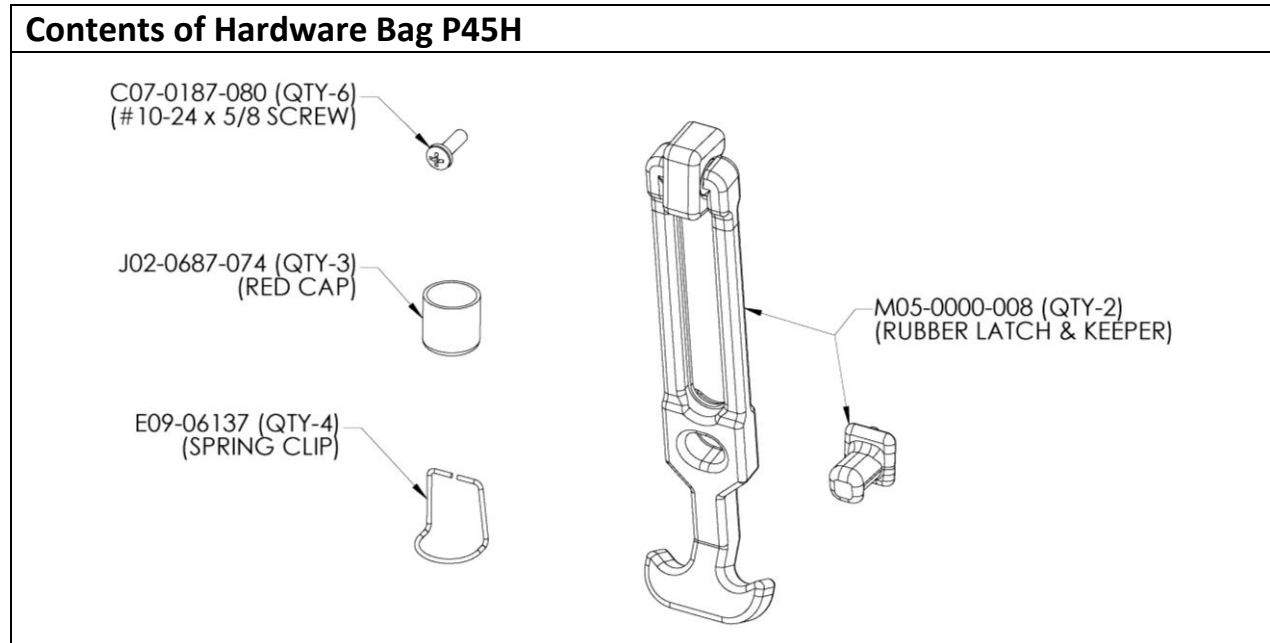

Complete Parts Break Down:

1..... Hopper Assemble, Poly Cam Gauge 2-Outlet, Straight Spouts (All Parts & Hardware in Place Unless Otherwise Specified)

1.....	M10-0001-300.....	P45 Hopper Body & Cover (45 Lb. Capacity)
		Use: 2 Decal, P45 Cam Gauge (N02-0001-111)
		2 Decal, Rotating Parts Inside (N02-0001-108)
		(P45 Hopper Replacement Cover Part #M10-0001-301)
1.....	M10-0001-302.....	Bottom Insert P45 (Silver)
1.....	09200.....	Support Plate, Poly Cam Gauge
1.....	M05-0030-006.....	Gasket, Bottom Cam Poly Hopper
2.....	09099926-7.....	Bottom Support Plate
		Use: 4 Hex Bolt (5/16 x 3/4 Stainless) (C03-0312-031)
		4 Wrought Washer (5/16) (C02-0312-030)
1.....	09099926-6.....	U-Frame, Poly Hopper
		Use: 4 Hex Bolt (5/16 x 1 Stainless) (C03-0312-045)
		4 Wrought Washer (5/16) (C02-0312-030)
2.....	09080821-5.....	Hanger Strap
		Use: 4 Lock Nut, Nylon (1/4) (C01-0250-040)
1.....	09099926-2C1.....	Bottom & Slide, 2-Outlet, Straight Spout
		Use: 2 Wing Nut (5/16) (C01-0312-020)
		2 SAE Washer (5/16) (C02-0312-020)
		2 Whiz Flange Nut (3/16) (C01-0187-030)
		2 Nylon Washer (1/4) (C02-0250-011)
		1 Rear Hanger, Slide (09072637)
		1 Lock Strip (09072638)
		1 Cam Gauge (0906375)
1.....	09069508.....	Rotor Bar, Rubber, 8-inch
		Use: 2 O-Ring (K03-0562-000)
		2 Washer, Stainless (09073507-7)
		4 Sponge Washer (1-1/2 x 5/16 x 5/8 I.D.) (C02-0625-051)
		2 Rotor Bar Spacer (09099926-11)
2.....	M05-0664-401.....	Gasket
2.....	090693.....	Bearing
2.....	09081826.....	Bearing Retainer
		Use: 2 Whiz Flange Nut (3/16) (C01-0187-030)

The Following Parts are shipped unassembled in Carton:

1..... P45 Hopper Cover

Hopper Assembly Parts Schematic

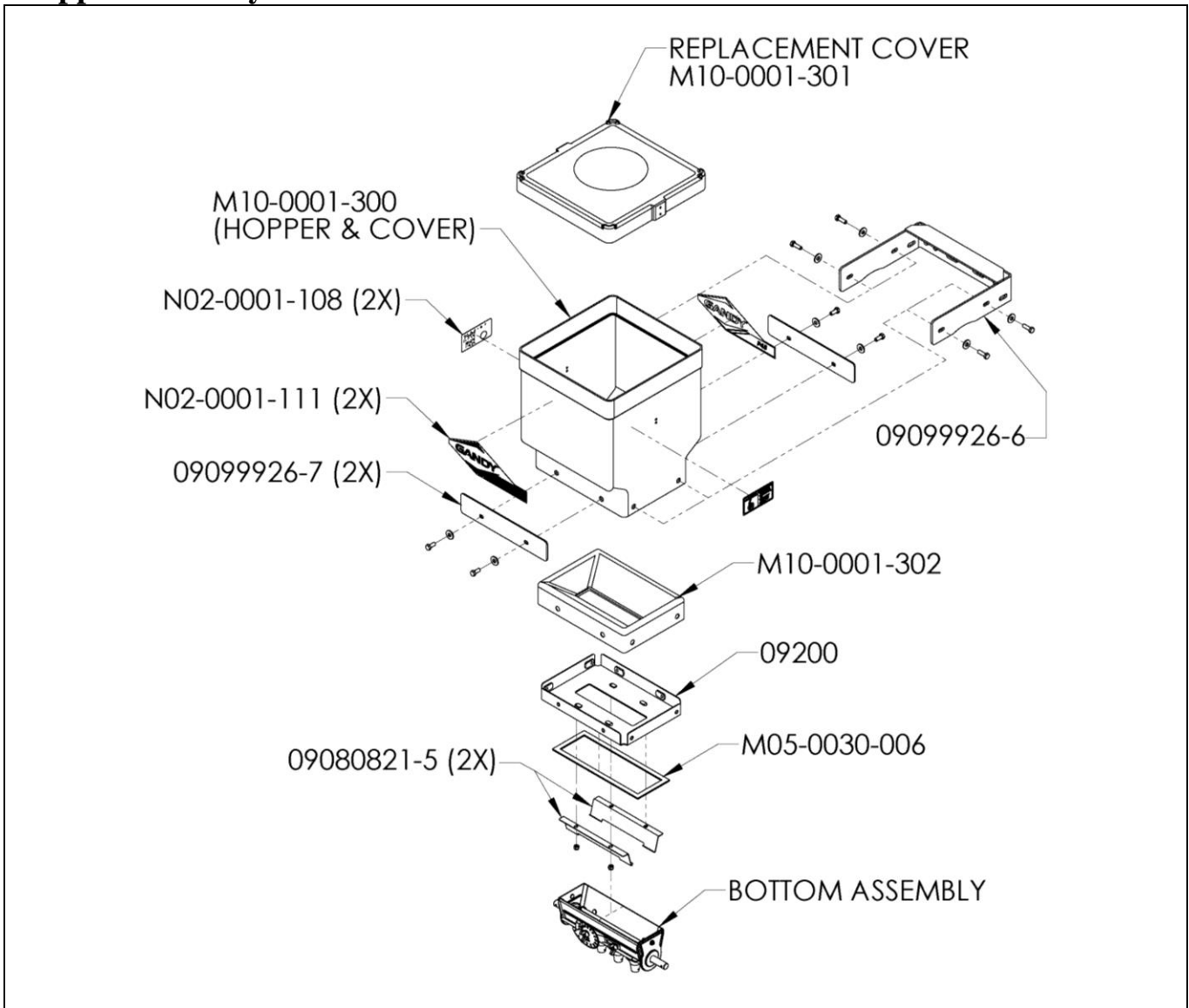

Bottom & Rotor Bar Assembly View

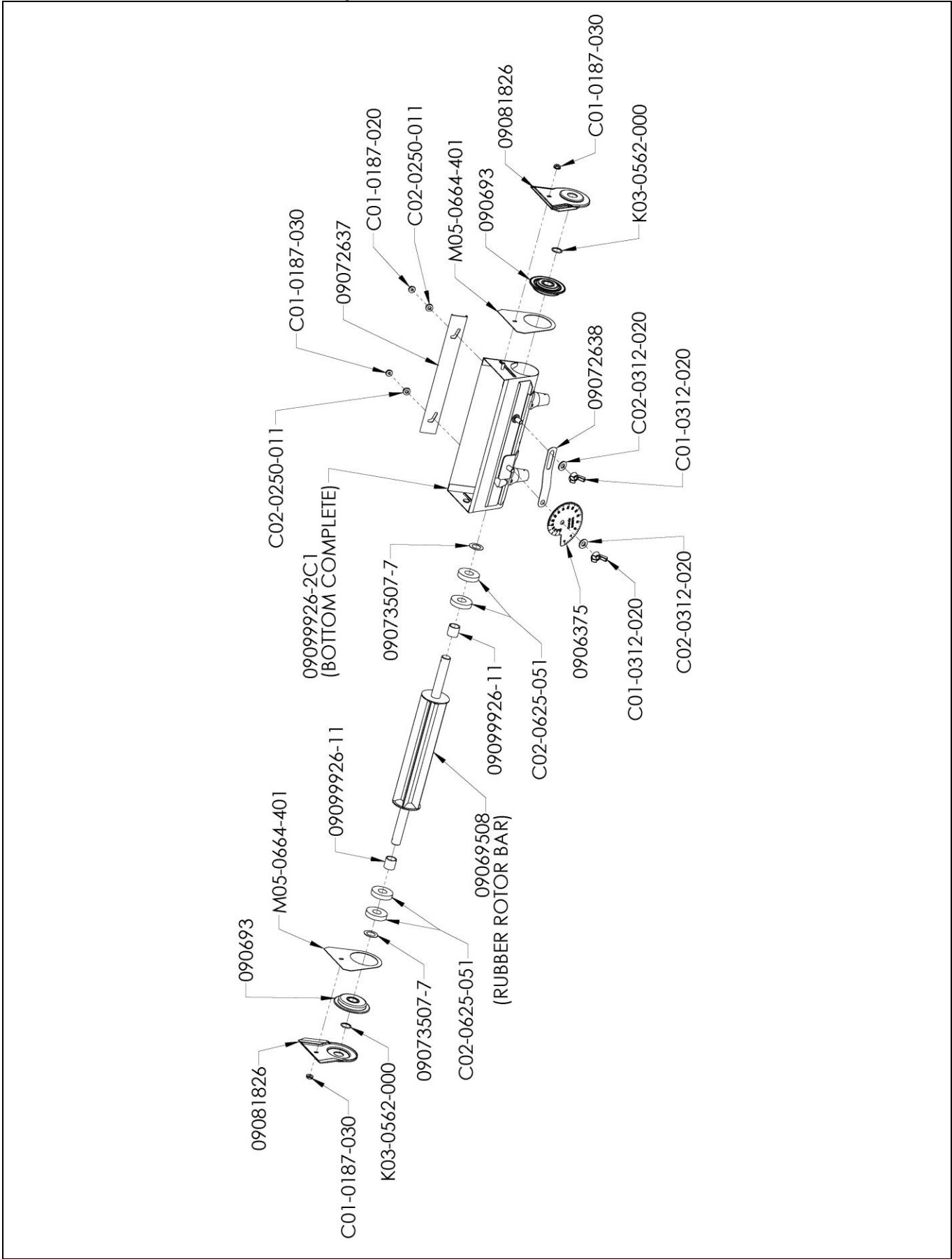

Cover / Rubber Latch Assembly

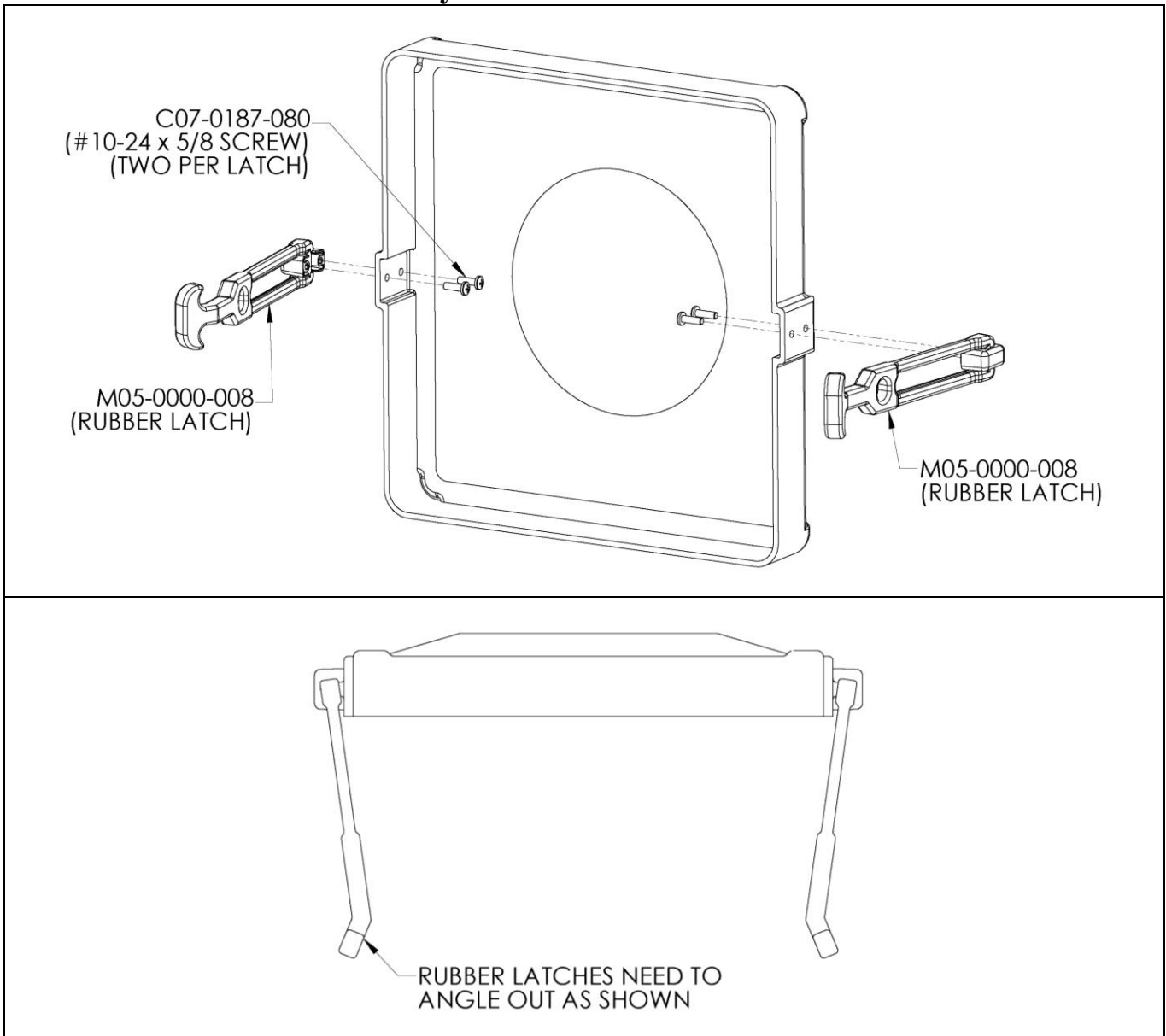

Assemble both rubber latches to the two holes on the side of the poly hopper cover using the #10-24 x 5/8 screws (C07-0187-080) as shown.

Hopper / Latch Keeper Assembly

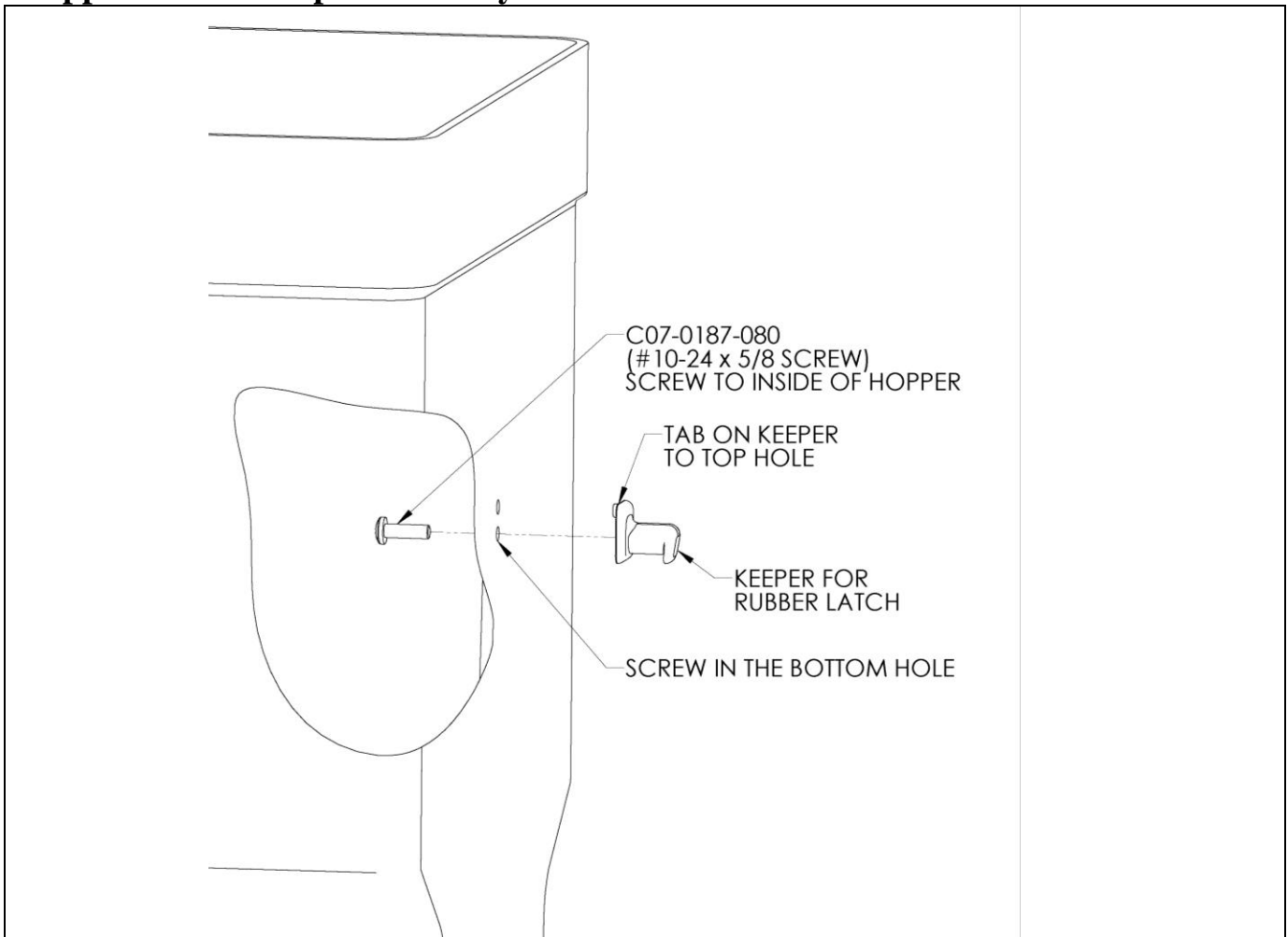

Assemble rubber latch keeper to the two holes on the side of the poly hopper using one #10-24 x 5/8 screw (C07-0187-080) as shown. Repeat for the second keeper on the other side of hopper.

Red caps and spring clips that are supplied in the hardware bag are used to close off outlets that are not needed. Push red cap onto spout and secure using the spring clip. Push ends of spring clip through red cap and into holes on both sides of spout.

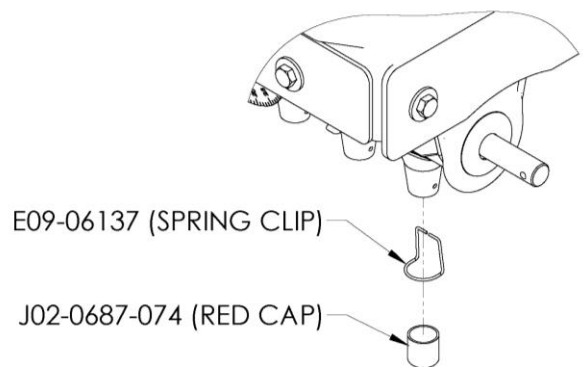

GDY-P452-R-PPL

Drawings: P45H, P45ASY, P45B2RST, P45-COVER-ASY, P45-K-ASY, P45-CAP

October 10, 2013
Printed in the USA