



# Illustrated Parts & Packing List

815 Rice Lake Street, Owatonna, MN 55060

For a complete distributor & dealer list go to [www.gandy.net](http://www.gandy.net)

## **P45PDMS MP<sup>+3</sup> Applicator Open Housing 4-outlet**

**Shipped w/ Chemical (C) Black, Fertilizer (F) Red Wheels  
& High Volume (V) Yellow Wheels**

**Can be configured for 1, 2, 3 or 4-outlets.**

**This unit is shipped without metering cups or wheels in place.  
See operator's manual for assembly instructions**

### **One carton Containing:**

- 1..... Hopper Assembly & Cover
- 1..... 09PDMS-B..... Parts Carton

### **09PDMS-B .....Parts Carton Contain the following:**

- 4..... M10-0001-040..... Metering Wheel, Fertilizer (F) (Red in Color)
- 4..... M10-0001-055..... Metering Wheel, High Volume (Yellow in Color)
- 4..... M10-0001-100..... Metering Cup, 1-1/4
- 4..... 09094899-6..... Hole Closure Half, PDM (Use w/ Black Wheels Only)
- 4..... 09094899-9..... Spout Adaptor for 7/8 I.D. Tubing (Use w/ Black Wheels Only)
- 2..... 09099927-10..... Agitator (Use Only if Needed)
- 4..... 62851-75..... Metering Wheel, Chemical (C) (Black in Color) w/ Inserts
- 8..... 62851-72..... Wear Plate, Stainless (Use Two per Metering Wheel)
- 3..... 62852-20..... Blank Plate

### **1..... 09PDMS-C ..... Parts Bag Containing the Following: (Shipped in P45PDMS-B)**

- 12 ..... C01-0187-030..... Whiz Flange Nut (3/16)
- 6 ..... C07-0138-050..... PH HD Tapping Screw (#6 x 3/8) (C07-0138-050)
- 6 ..... C07-0187-080..... Pan Head Stainless Screw (#10-24 x 5/8)
- 2 ..... C07-0187-111..... Pan Head Stainless Screw (#10-24 x 1)
- 2 ..... M05-0000-008..... Rubber Latch & Keeper

## Parts Carton P45PDMS-B Contents

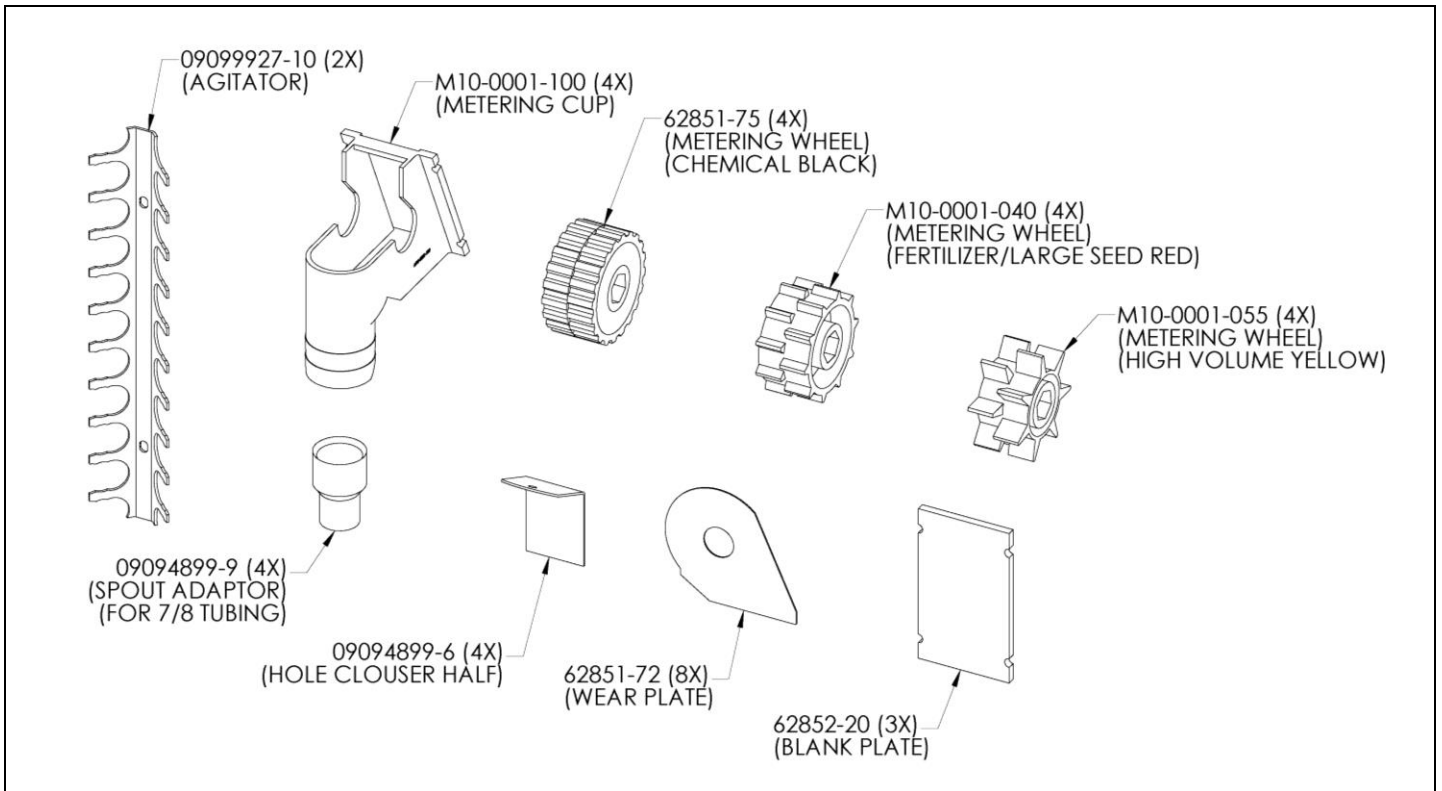

## Parts Bag P45PDMS-C Contents

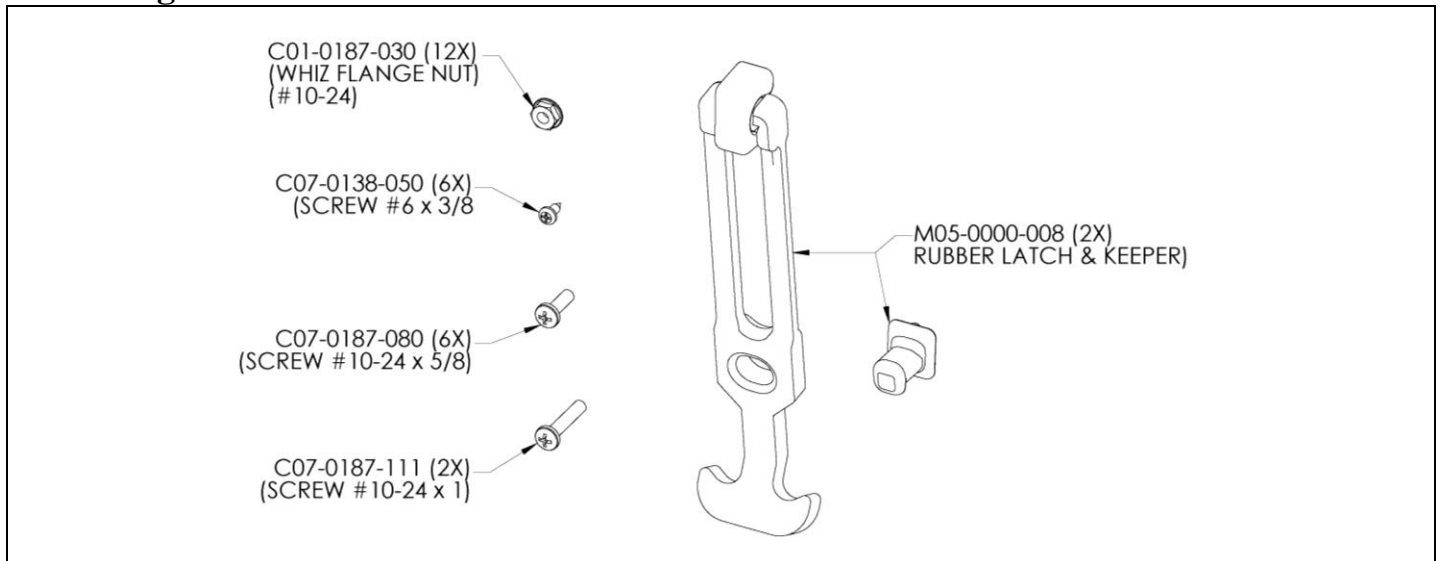

## P45PDMS-A Hopper Assembly

1	M10-0001-300	P45 Hopper Body Polyethylene, Use: 2 Decal, P45-PDMS (N02-0001-112) 2 Decal, Rotating Parts Inside (N02-0001-108)
1	09001953-1	Front Sheet, Stainless Poly Use: 4 Hex Bolt (1/4 x 1/2 Stainless) (C03-0250-013) 4 Whiz Flange Nut (1/4 Stainless) (C01-0250-032)
1	09001953-2	Rear Sheet, Stainless Poly
1	09001953-3	Side Sheet, Left Use: 4 Hex Bolt (1/4 x 1/2 Stainless) (C03-0250-013) 4 Whiz Flange Nut (1/4 Stainless) (C01-0250-032)
1	09001953-4	Side Sheet, Right Use: 4 Hex Bolt (1/4 x 1/2 Stainless) (C03-0250-013) 4 Whiz Flange Nut (1/4 Stainless) (C01-0250-032)
2	09094899-2	Bearing Holder PDM Use: 8 SAE Washer (5/16) (C02-0312-020) 2 Wing Nut (5/16) (C01-0312-020)
1	M05-1375-000	Rubber Plug (1-3/8 Snap-Tite)
4	090693	Bearing, End (for 5/8 Shaft)
1	09099927-8	Shaft, Metering Wheel (5/8 Hex) Use: 4 Washer .656 I.D. (C02-0656-070) 2 Hair Pin Cotter (1/8 x 1-15/16) (C21-0125-020)
1	09099927-9	Shaft, Drive (5/8 Round) Use: 2 O-Ring (K03-0562-000) 2 Washer .656 I.D. (C02-0656-070) 2 Cotter Pin (3/16 x 1-1/4) (C20-0187-030)
1	09099926-6	U-Frame, Poly Hopper Use: 4 Hex Bolt (5/16 x 1 Stainless) (C03-0312-045) 4 Wrought Washer (5/16) (C02-0312-030)
1	09099945-1	Windshield
2	09099926-7	Bottom Support Plate Use: 4 Hex Bolt (5/16 x 3/4 Stainless) (C03-0312-031) 4 wrought Washer (5/16) (C02-0312-030)

### The Following Parts are shipped unassembled in Carton:

1	M10-0001-301	Cover, P45 Polyethylene Hopper
---	--------------	--------------------------------

# P45PDMS-A Hopper Assembly

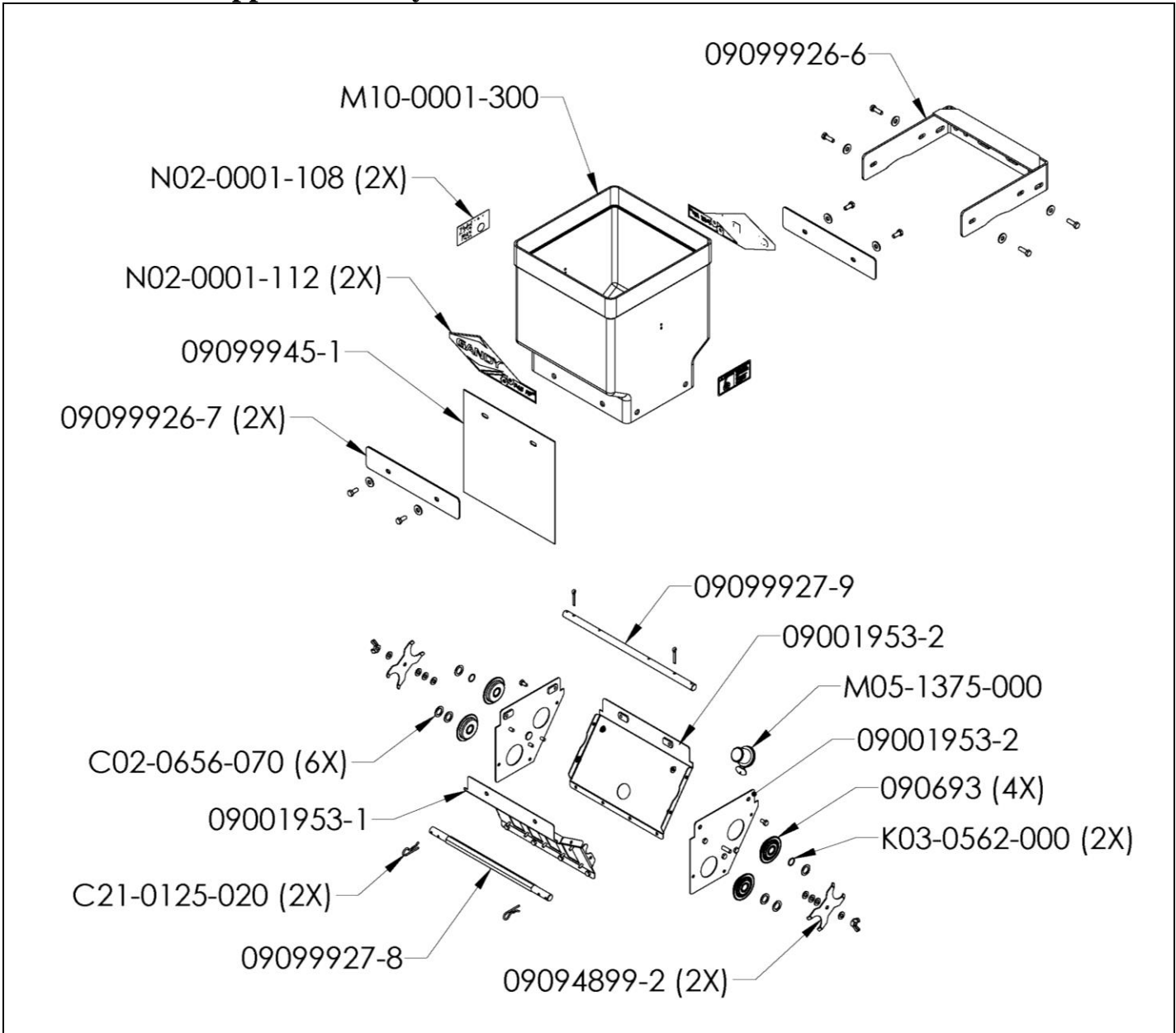

See operator's manual for assembly instructions

# Cover Assembly

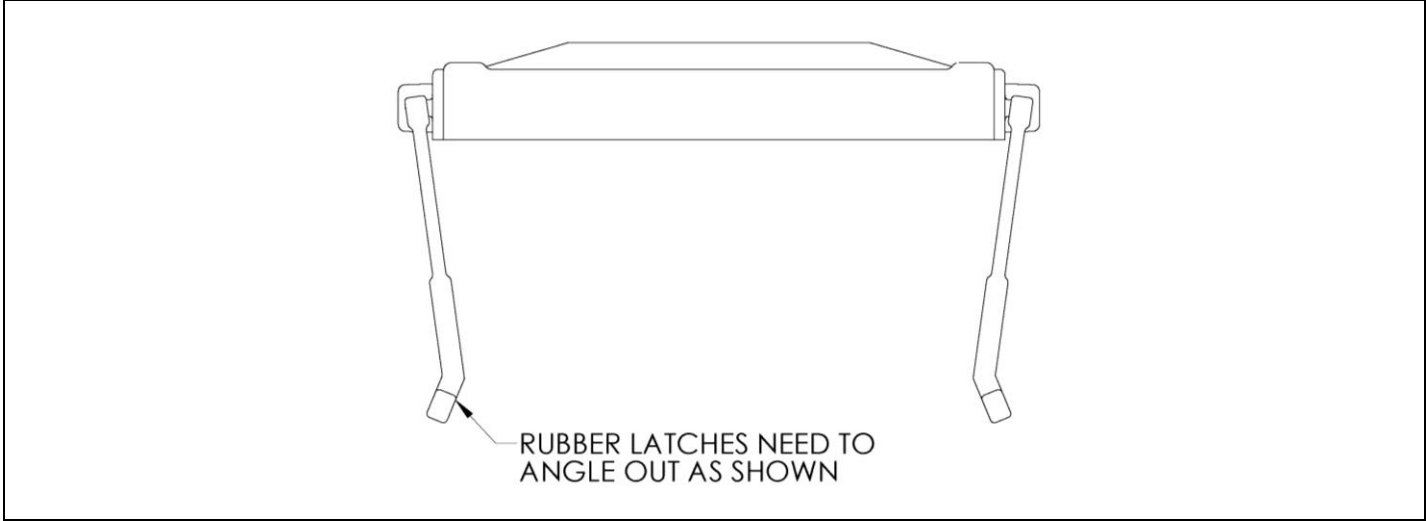
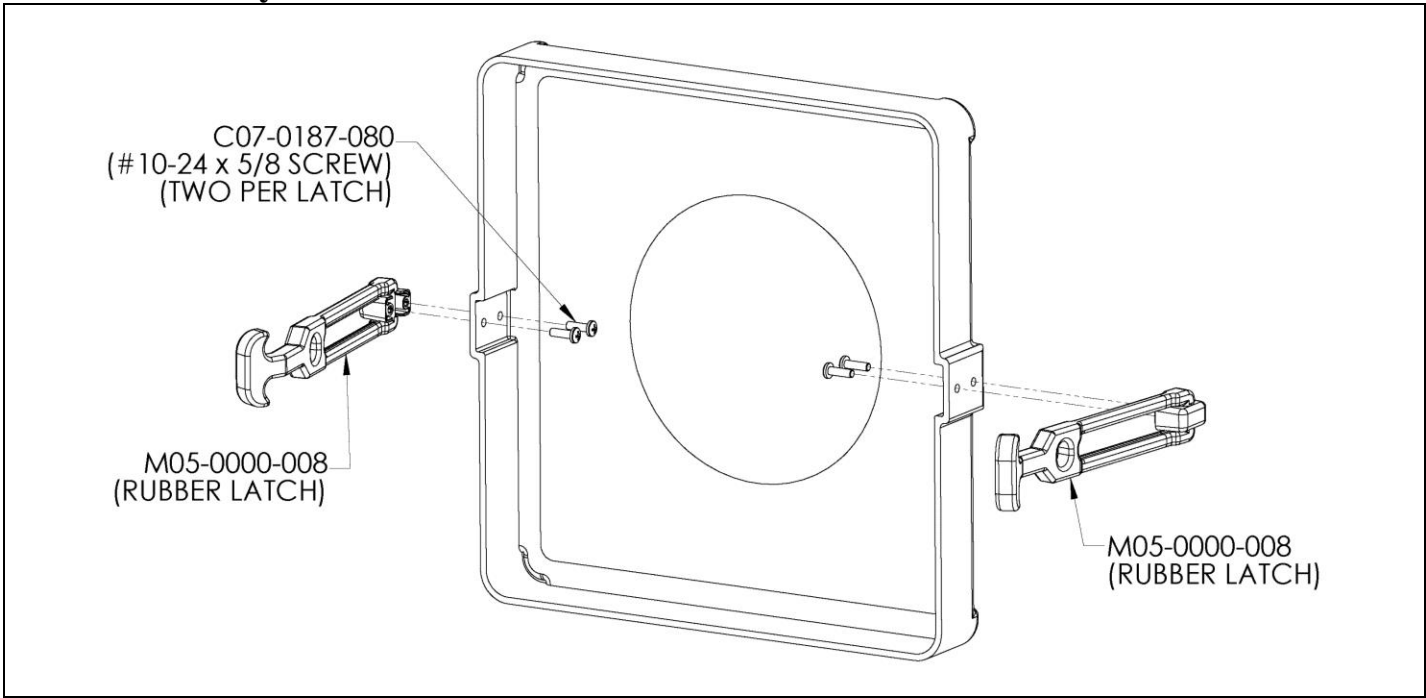

## Hopper Latch Keeper Assembly

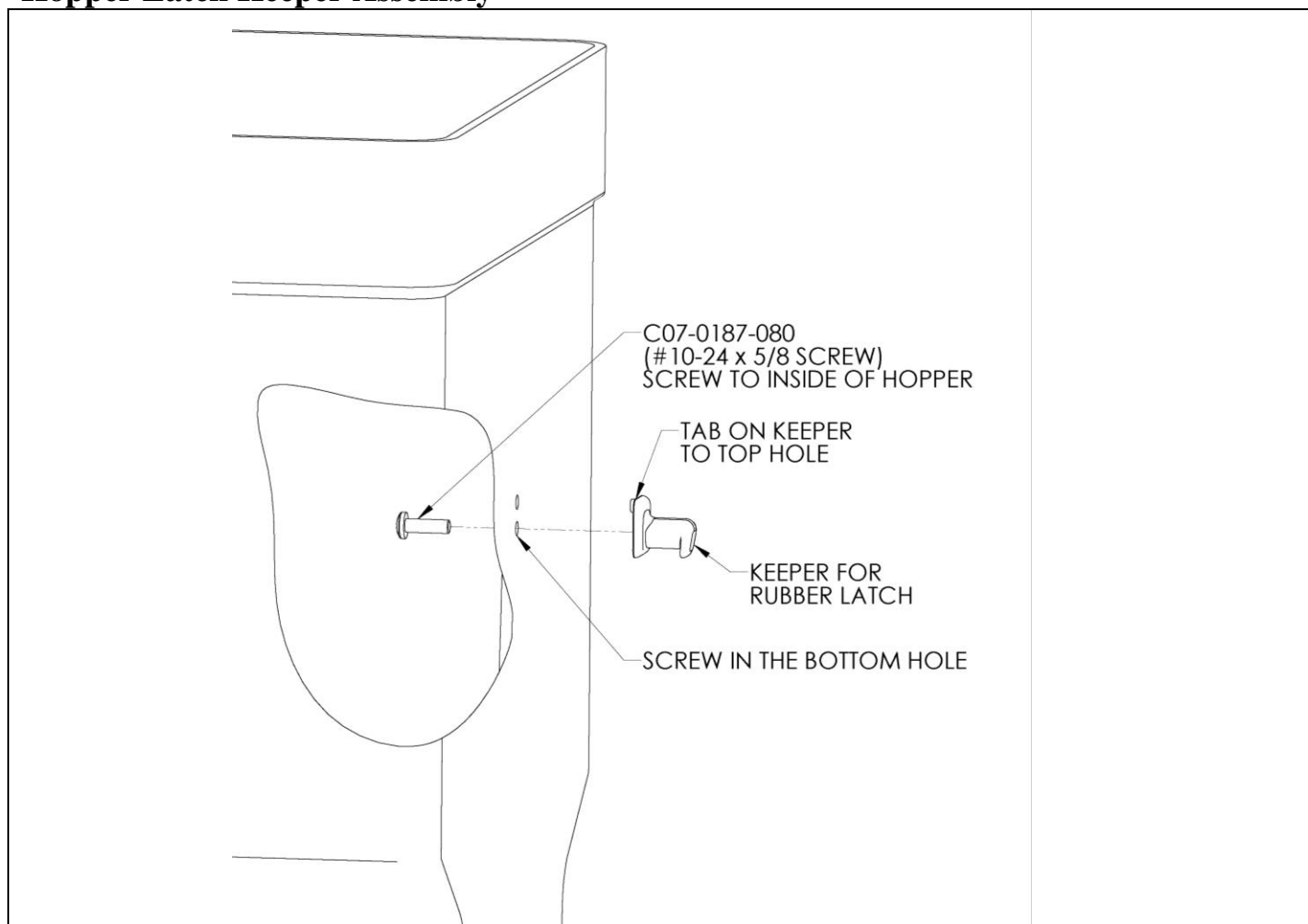

Assemble rubber latch keeper to the two holes on the side of the poly hopper using one #10-24 x 5/8 screw (C07-0187-080) as shown. Repeat for the second keeper on the other side of hopper.

GDY-P45PDMS-PPL  
October 16, 2012  
Printed in the USA