



Illustrated Parts & Packing List

815 Rice Lake Street, Owatonna, MN 55060

For a complete distributor & dealer list go to www.gandy.net

P45TALC12

Slotted Bottom Talc Applicator

Cam Gauge Controlled, 1 Cu. Ft. Capacity Poly Hopper

Five 1/2" x 1-1/4" Adjustable Slots

12-Volt Electric Motor Drive (1/64-Hp)

(All Parts & Hardware in Place Unless Otherwise Specified)

Carton Containing the Following Assembled Hopper & 2 Hardware Bags

1..... P45TALC12P45 Hopper, Talc Slotted Bottom, 12-Volt Motor Drive

- 1 M10-0001-300.....P45 Hopper Body & Cover, 1 Cu. Ft. Capacity
 - Use: 2 Decal, P45 Talc (N02-0001-115)
 - 2 Decal, Rotating Parts Inside (N02-0001-108)
 - (P45 Hopper Replacement Cover Part #M10-0001-301)
- 1 09099936-1.....Center Section, Slotted Bottom Housing
 - Use: 1 Decal, Warning Never Place Fingers (N02-0057-000)
- 2 09099936-3.....End Plate, Slotted Bottom (L&R)
 - Use: 12 Hex Bolt (1/4 x 1/2) (C03-0250-010)
 - 12 Whiz Flange Nut (1/4) (C01-0250-030)
- 1 09099936-14.....Stop, Cam Gauge
 - Use: 2 Carriage Bolt (3/16 x 1/2) (C04-0187-010)
 - 2 Whiz Flange Nut (3/16) (C01-0187-030)
- 1 09008961-2.....Slotted Slide, High Rate, (5) 1/2" x 1-1/4" Adjustable Slots
 - Use: 6 Lock Nut, Nylon (3/16) (C01-0187-040)
 - 6 SAE Washer (3/16) (C02-0187-020)
 - 6 Spring (09099936-12)
- 1 0906375.....Cam-Gauge
 - Use: 2 SAE Washer (5/16) (C02-0312-020)
 - 1 Wing Nut (5/16) (C01-0312-020)
- 6 090693.....Bearing, End (.625 I.D.)
- 2 09099936-4.....Bearing Retainer
 - Use: 2 Wing Nut (5/16) (C01-0312-020)
 - 8 SAE Washer (5/16) (C02-0312-020)
- 2 09099936-7.....Shaft (13.25/32 x 5/8 Round) (Use Fluted Agitators)
 - Use: 2 Washer (.656 I.D.) (C02-0656-070)
 - 2 Cotter Pin (3/16 x 1-1/4) (C20-0187-030)
- 1 09099936-8.....Shaft (15-31/32 x 5/8 Round) (Use Solid Agitator)
 - Use: 1 Washer (.656 I.D.) (C02-0656-070)
 - 1 Cotter Pin (3/16 x 1-1/4) (C20-0187-030)

- 4 09099936-5.....Agitator, Fluted
 Use: 4 Pan Head Screw (#10-24 x 1 Stainless) (C07-0187-111)
 4 Whiz Flange Nut (3/16) (C01-0187-030)
- 2 09099936-6.....Agitator, Solid
 Use: 2 Pan Head Screw (#10-24 x 1 Stainless) (C07-0187-111)
 2 Whiz Flange Nut (3/16) (C01-0187-030)
- 3 09094900-22.....Shaft Connector (2-1/2 Long)
 Use: 3 Washer (.656 I.D.)(C02-0656-070)
 3 Cotter Pin (3/16 x 1-1/4) (C20-0187-030)
 3 Spring (.055 Wire) (E00-0885-008)
 3 Hairpin Cotter (1/8 x 1-15/16) (C21-0125-020)
- 3 09094900-11.....Sprocket 14-Tooth (5/8 Hex Bore)
- 1 F02-0065-032Roller Chain #43 (32-Rollers)
 Use: 1 Connector Link #43 (F02-0065-001) (part of F02-0065-032)
- 1 09094900-20.....Chain Guard (Plastic)
- 1 09099936-9.....Chain Guard Bracket
 Use: 1 Decal, Caution Chain Guard (N02-0009-060)
 2 Hex Bolt (1/4 x 1/2) (C03-0250-010)
 2 Wrought Washer (1/4) (C02-0250-020)
 2 Whiz Flange Nut (1/4) (C01-0250-030)
 1 Hex Bolt (3/8 x 1) (C03-0375-040)
 1 Shake Proof Washer (3/8) (C02-0375-040)
 1 Wrought Washer (3/8) (C02-0375-030)
 1 Lock Washer (3/8) (C02-0375-010)
 1 Hex Nut (3/8) (C01-0375-010)
- 2 09099926-7.....Bottom Support Plate
 Use: 4 Hex Bolt Stainless (5/16 x 3/4) (C03-0312-031)
 4 Wrought Washer (5/16) (C02-0312-030)
- 1 09099926-6.....U-Frame, Poly Hopper
 Use: 2 Hex Bolt Stainless (5/16 x 1) (C03-0312-045)
 2 Wrought Washers (5/16) (C02-0312-030)
- 1 09099926-8.....Motor Mount Bracket, Poly-Hopper
 Use: 2 Hex Bolt Stainless (5/16 x 1) (C03-0312-045)
 2 Wrought Washers (5/16) (C02-0312-030)
- 1 09071589-8.....Drive Sprocket 24-Tooth (2-3/4 Hub)
 Use: 1 Cotter Pin (3/16 x 1-1/4) (C20-0187-030)
- 1 09075589-4.....Electric Motor Assembly, 12-Volt, 1/64 HP, 4 Amp
 Use: 1 Super Flange Nut (1/4-24) (Replacement Part) (C01-0250-031)
 1 Sprocket, 8-Tooth (Replacement Part) (G01-0008-010)
 1 Decal, Electric Motor 12-Volt (N02-0009-050)
 3 Pan Head Mach Screw (1/4-28 x 1/2) (C07-0250-070)
 3 Shake Proof Washer (#1114) (C02-0250-040)
- 1 09077589-3.....Motor Mount, Electric Motor
 Use: 2 Whiz Flange Nut (1/4) (C01-0250-030)-(Part of 09077589-3)
 1 S-Hook (#63) (M11-0063-000)
 1 Cable Tie w/ Eye (1/8 x 5) (L04-0002-000)
 1 Decal, EM Caution (N02-0009-052)
 2 Hex Bolt Stainless (5/16 x 3/4) (C03-0312-031)
 2 Wrought Washer (5/16) (C02-0312-030)
 2 Whiz Flange Nut (5/16) (C01-0312-030)
- 1 F02-0041-051Roller Chain #41 Endless (51-Link)
- 1 09099936-10.....Chain Guard, Slotted Bottom
 Use: 1 Decal, Caution Chain Guard (N02-0009-060)

Continued on next page....

1.....09099936-H.....Hardware Bag Containing:

- 1..... C01-0164-040.....Kep Nut (#8-32)
- 1..... C07-0164-051.....Pan Head Machine Screw (#8-32 x 3/8)
- 1..... C20-0187-030.....Cotter Pin (3/16 x 1-1/4)
- 2..... L03-0003-000.....Molded Connector, 8-inch (Female End)
- 1..... L03-0003-040.....Molded Connector, 8-inch (Male End)
- 8..... L03-0005-000.....Wire Connector 18-14 Ga. Blue
- 1..... L05-0001-000.....Switch, Push/Pull
- 1..... 09071589-11.....Electric Wire Red, 8-Feet, w/Fork & Ring Terminal (Power Wire)
- 1..... 09073589-9.....Switch Mount Bracket
- 1..... 09082589-31.....Molded Connector, 8-inch w/Fork Terminals (Male End)
- 2..... 09084589-32.....Electric Rip Cord, Red/Brown (16 ga. x 11-Feet)

1.....P45TALC-H.....Hardware Bag Containing The Following:

- 2 M05-0000-008.....Rubber Draw Latch & Keeper
- 6 C07-0187-080.....Pan Head Stainless Screw (#10-24 x 5/8)

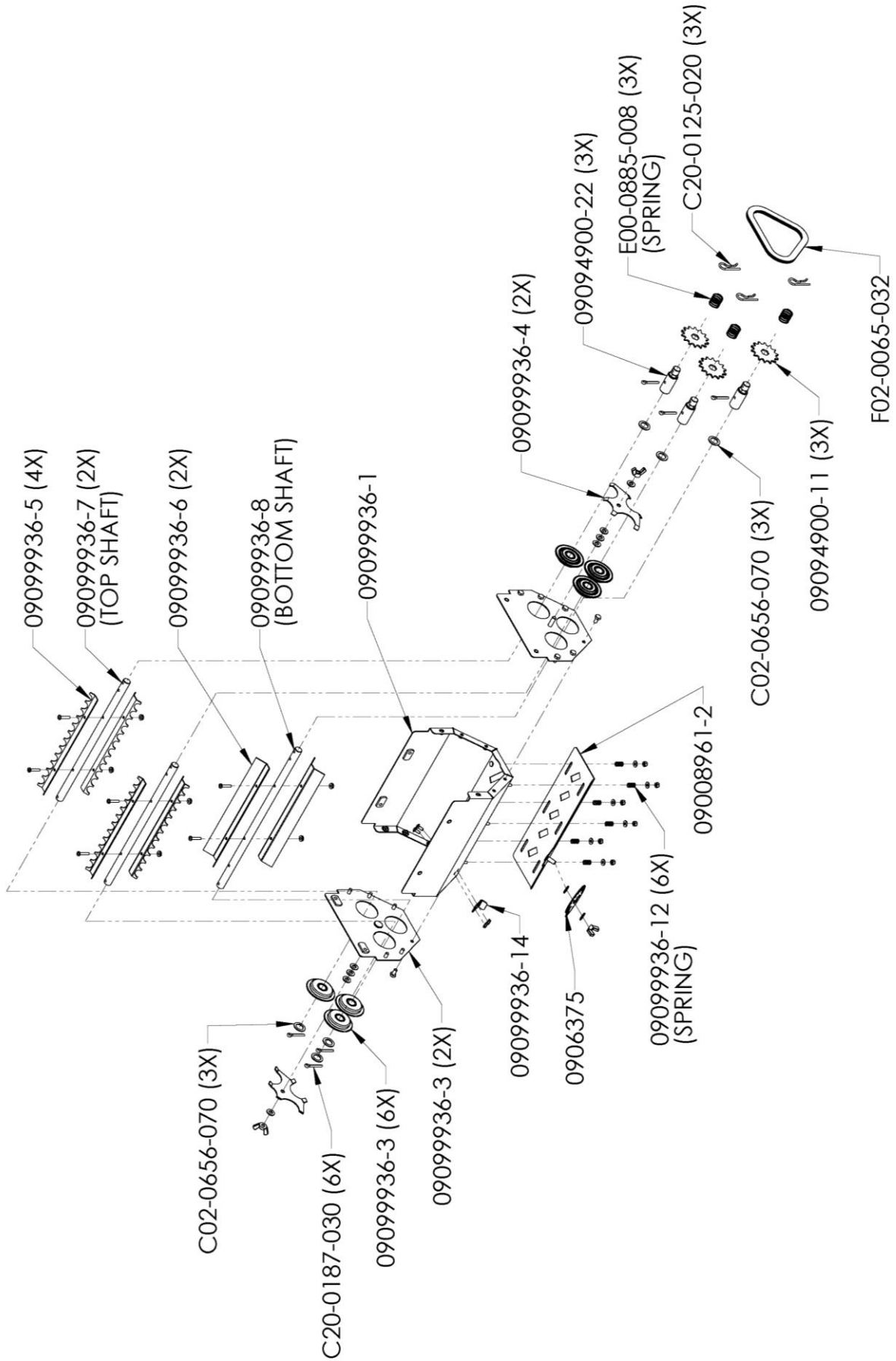

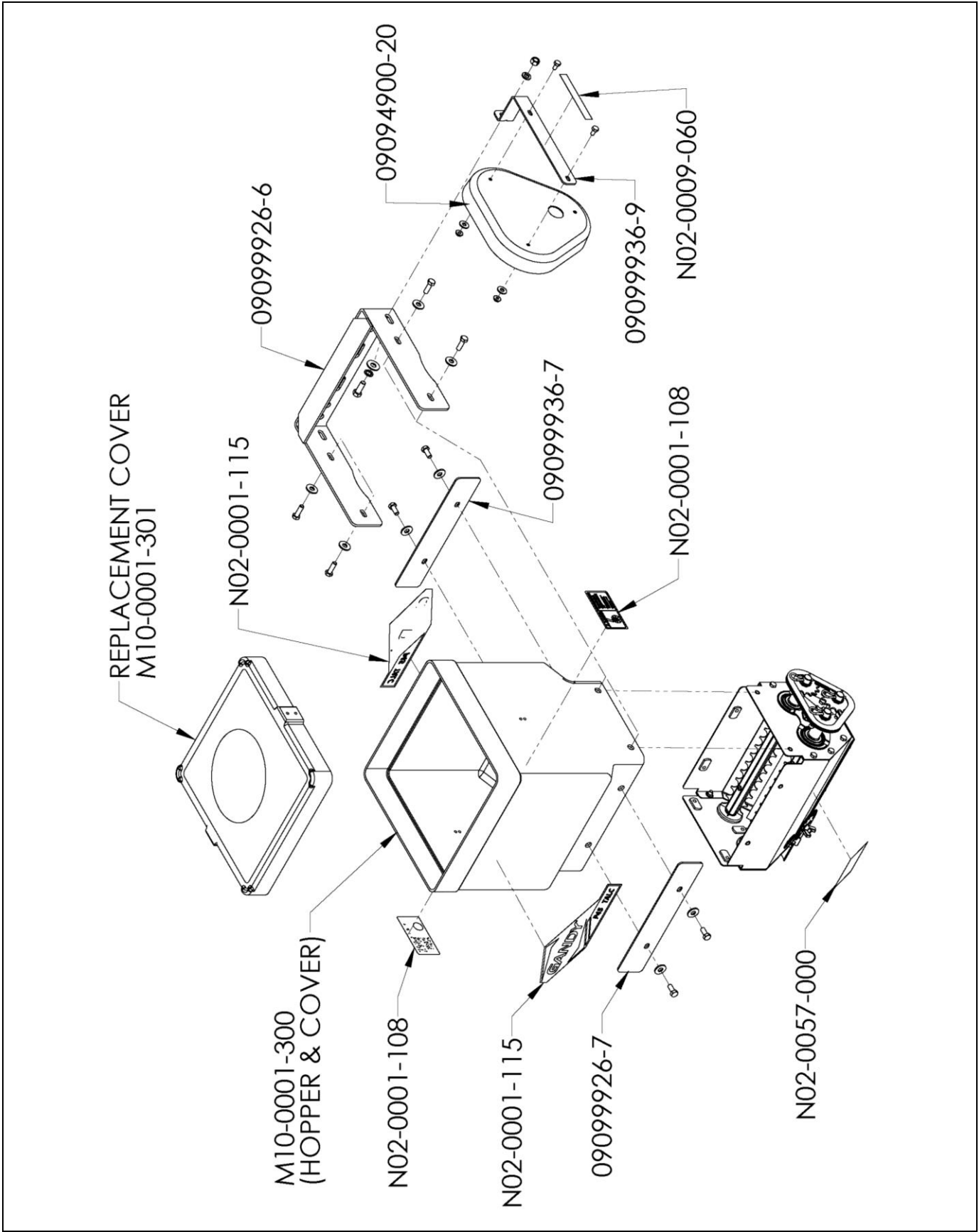

Electric Motor Mounting & Parts Schematic

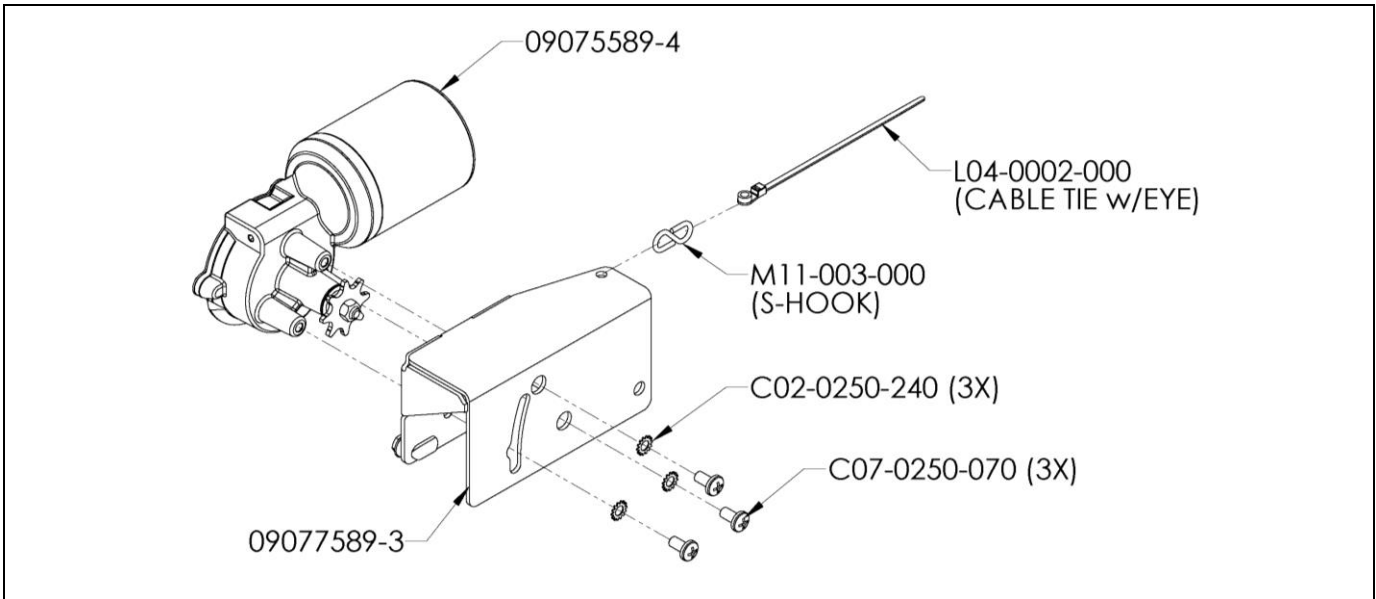
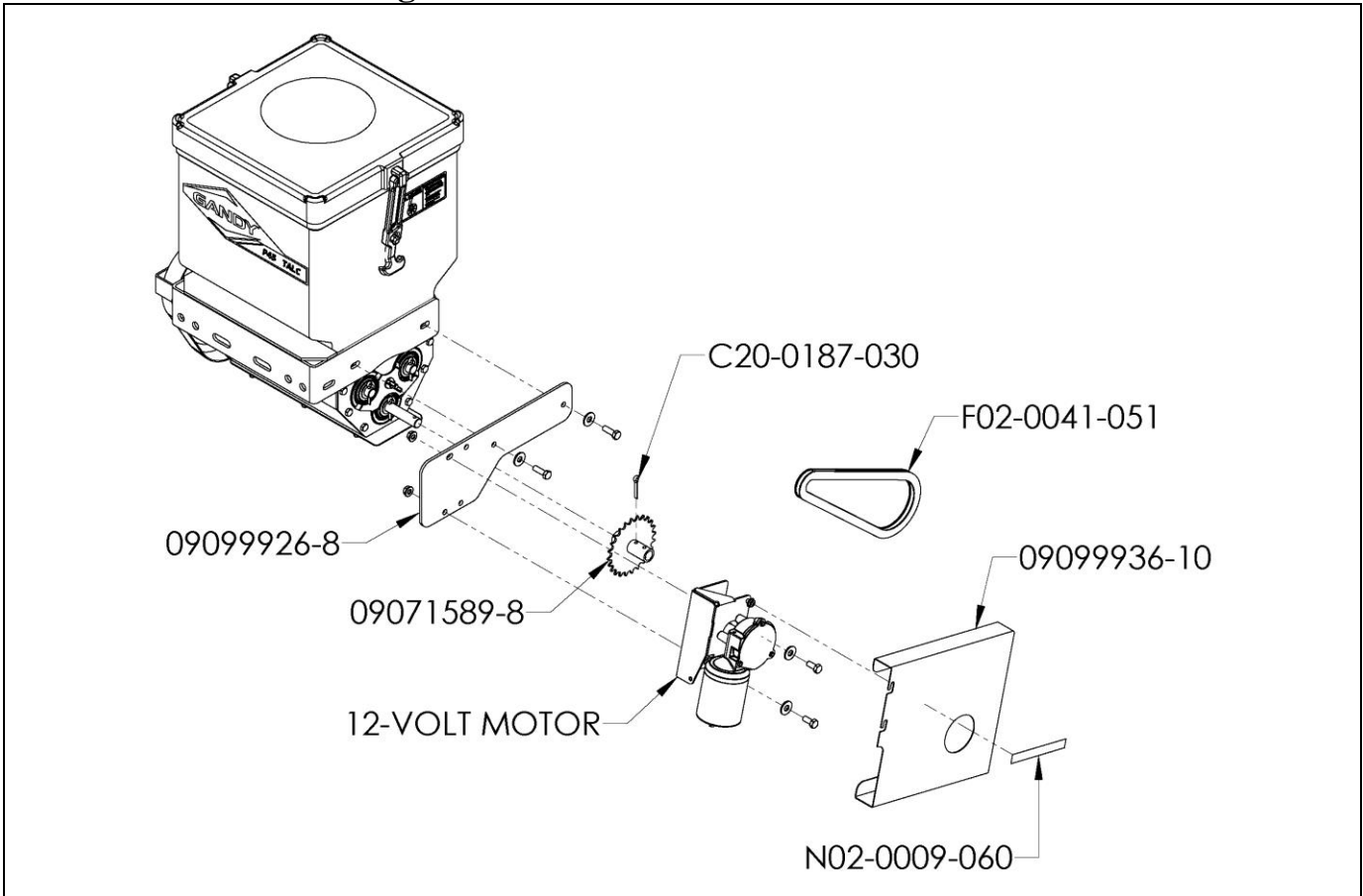

12-Volt electric motor wiring: Green (+) / Black (-).
(NOTE: Screws & Shake Proof Washers are a part of electric motor.)

Cover / Rubber Latch Assembly

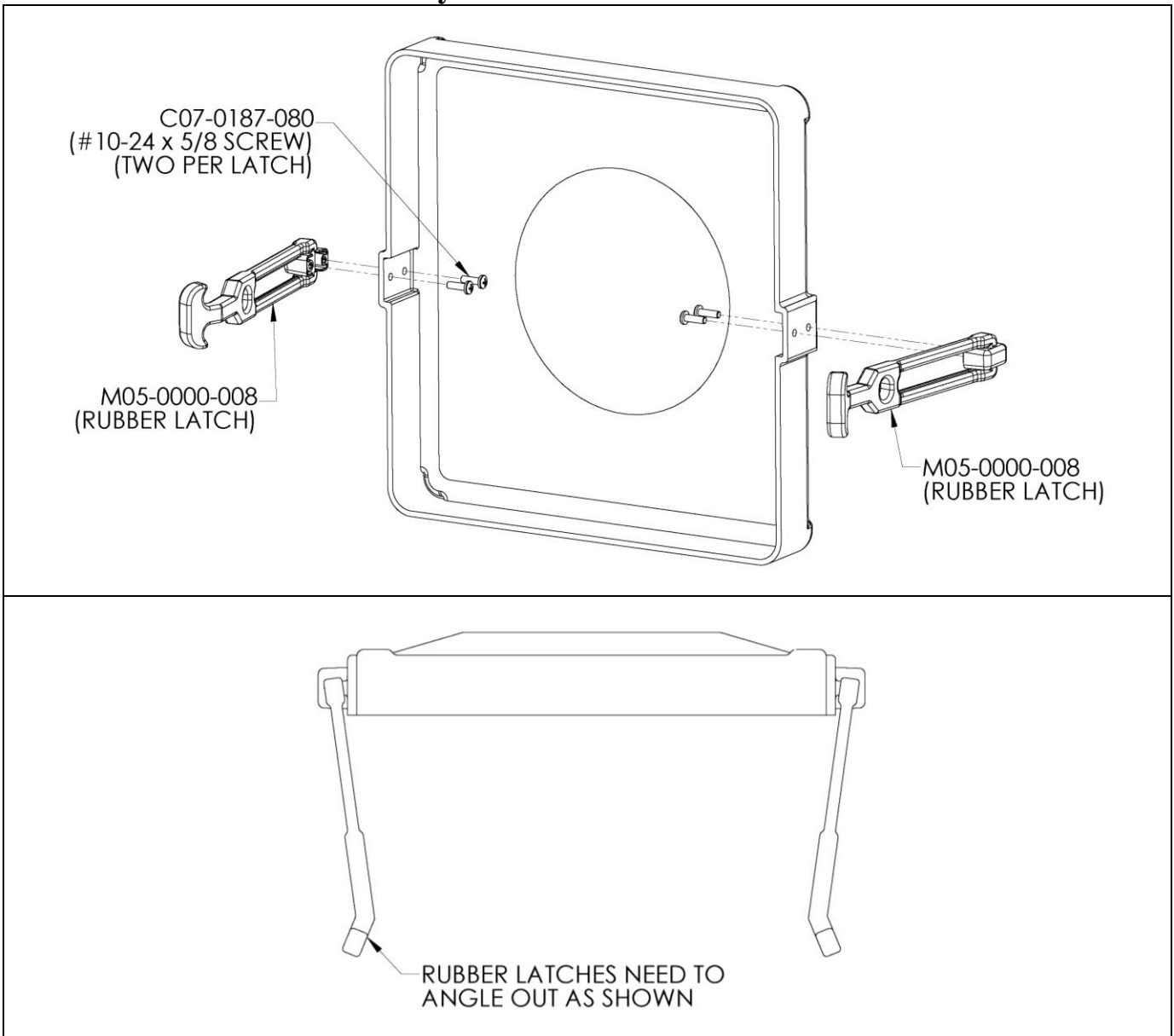

Assemble both rubber latches to the two holes on the side of the poly hopper cover using the #10-24 x 5/8 screws (C07-0187-080) as shown.

Hopper / Latch Keeper Assembly

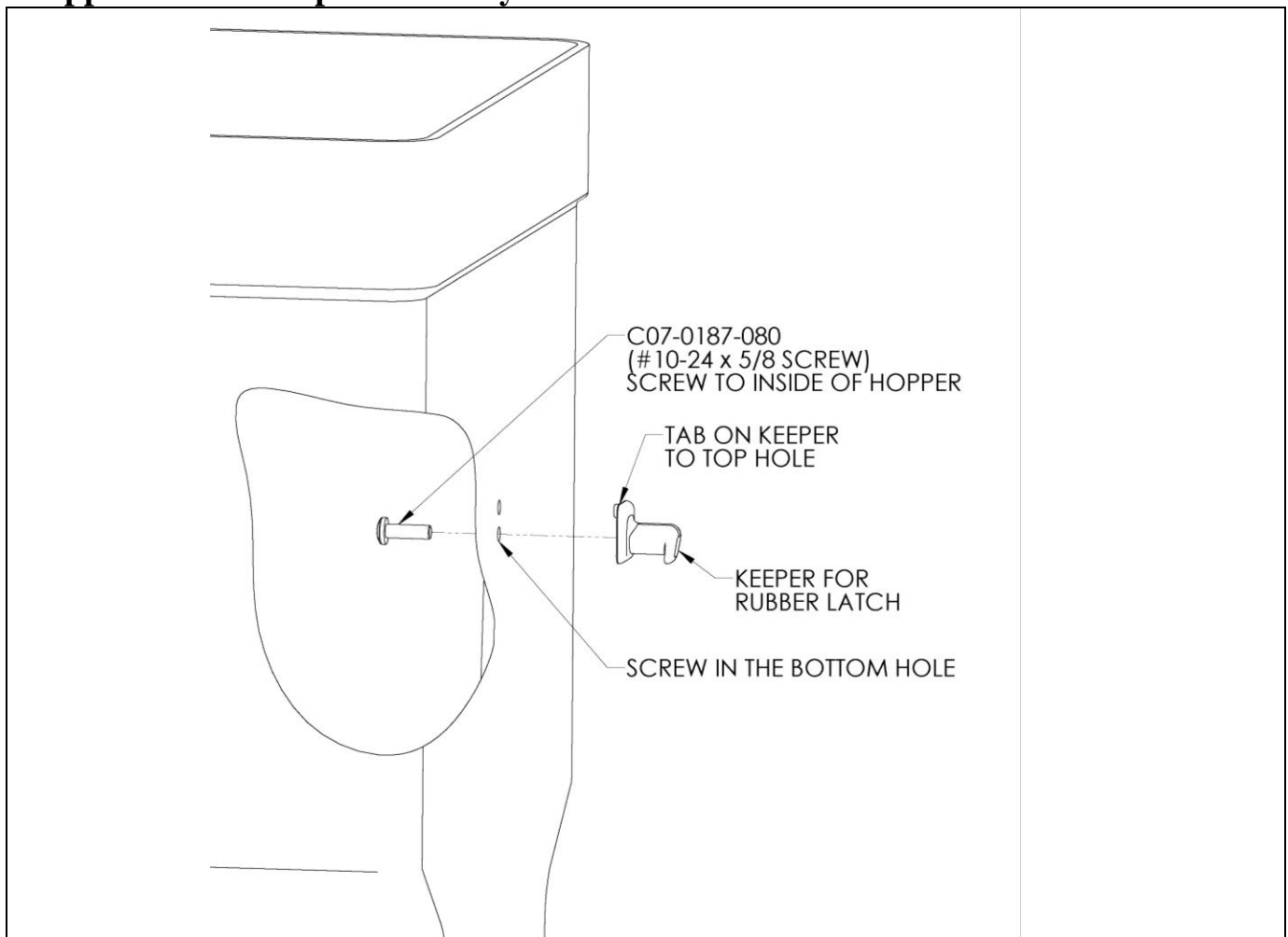

Assemble rubber latch keeper to the two holes on the side of the poly hopper using one #10-24 x 5/8 screw (C07-0187-080) as shown. Repeat for the second keeper on the other side of hopper.

Wiring Diagram & Switch Assembly

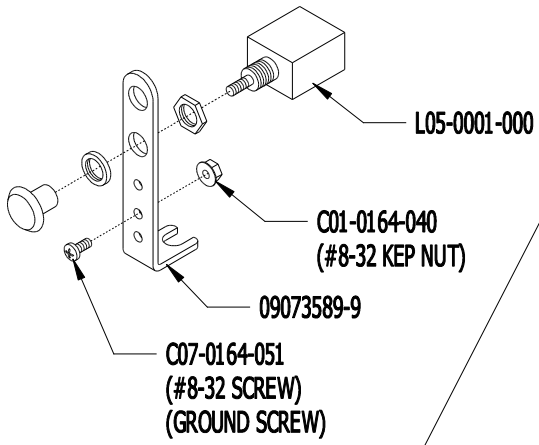

WIRING DIAGRAM

09099936-E
4/3/07

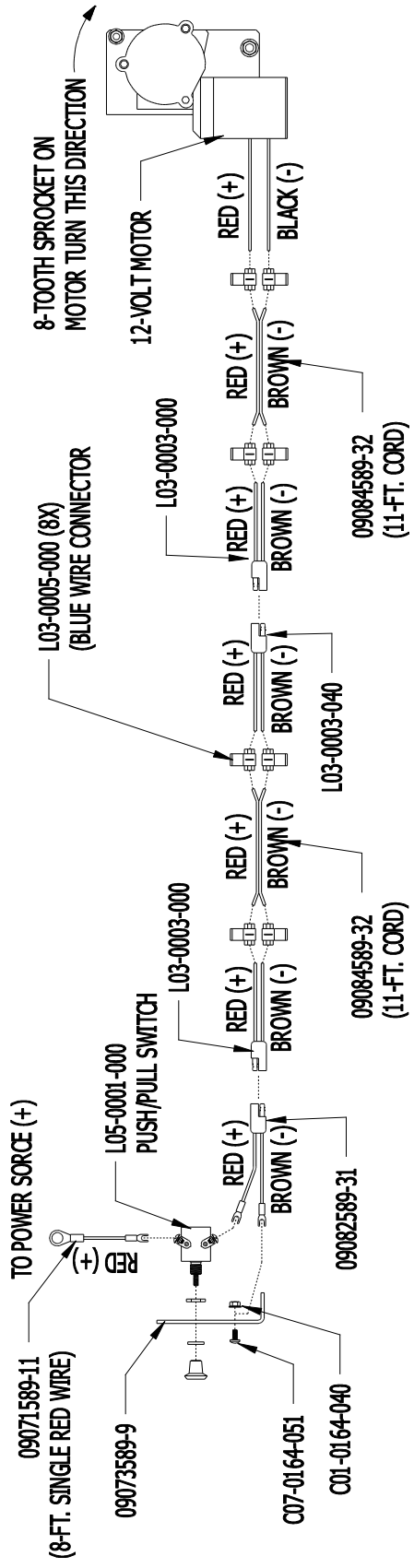

Installation Instructions

1. Attach switch mounting bracket (09073589-9) to a convenient location in the tractor operator area.
Note: Ground wire connects back to switch bracket to ground. Switch needs to make good metal to metal contact to achieve this or motor will not run. If a good ground cannot be achieved you can run a wire from the switch bracket back to the frame or negative terminal on the battery.
2. Attach large terminal end of 8-foot red wire (09071589-11) to desired power source, such as live terminal on ignition switch or battery. Be sure you have 12-volts of current. Attach other end to either terminal of switch. (See Wiring Diagram)
3. String the wire from switch back to motor. Use ty-raps to keep wire in place.
If you do not need the full length of wire, cut off excess to keep the drop in voltage to a minimum.
4. Check to see if sprocket on motor turns as shown in wiring diagram.
5. Be sure hoppers are clean and free of foreign objects before using.

Operating Instructions

1. Check to see if there are any foreign materials in the hopper.
2. Remove chemical at the end of each day so that you start with fresh material!
If a “frozen” hopper is not freed-up, it will put more strain on the motor.
3. The adjustable slots are 1/2-inch wide at the maximum setting.
Calibration is checked by timing the delivery by flow per minute.
Some common peat-based products have been tested at a rate of about 5 pounds per minute at this maximum opening. After checking the flow rate at maximum, the slot may be narrowed using the cam gauge adjustment. How much the opening may be closed will depend on the flow characteristics of the individual product base. The user will have to determine the proper dispensing rate for the flow of seeds being inoculated.

General Information

IMPORTANT!

Road travel with hoppers filled can cause compaction of some chemicals. This compaction can make it difficult for the motor to start. Therefore, try to fill hoppers just before use at the field.

NOTE: The motor will run hot under normal load.

Under normal load with two hoppers, each motor will draw between 2 and 3 amps. Under adverse conditions, the load will increase up to 5 amps. If the power usage increases about 5 amps, one or both of the following steps should be taken to reduce the power usage and prolong the life of the motor.

1. Check to see if there are any foreign materials in the hopper.
2. Check to see if that the bearings are clean and rotors turn freely.

GDY-P45TALC12-PPL

Drawings: P45TALC-BOTTOM, P45TALC110, P45TALK-12VOLT DRIVE, P45ELEC12VOLT, P45-COVER-ASY, P45-K-ASY, 09099936-E

March 7, 2014
Printed in the USA