



# Illustrated Parts & Packing List

815 Rice Lake Street, Owatonna, MN 55060

For a complete distributor & dealer list go to [www.gandy.net](http://www.gandy.net)

## 410L

### 10-Foot Linear Implement Mounted Applicator

(All Hardware in Place Unless Otherwise Specified)

1	1410801	Hopper, 10 Foot Linear
		Use: 1 Decal, Linear Hopper (N02-0001-103)
1	14106317-1	Cover, Left (For 10-foot Linear Hopper)
		Use: 1 Decal, Caution (N02-0014-010)
		1 Decal, Important (N02-0014-020)
		2 Clevis Pin (1/4 x 2-5/8) (C22-0250-200)
		2 Cotter Pin (9/32 x 3/4) (C20-0093-020)
1	14106317-2	Cover, Right (For 10-foot Linear Hopper)
		Use: 2 Clevis Pin (1/4 x 2-5/8) (C22-0250-200)
		2 Cotter Pin (9/32 x 3/4) (C20-0093-020)
4	1406318	Cover Lock (2 Used on Each Cover)
		Use: 4 Cotter Pin (9/32 x 3/4) (C20-0093-020)
2	140692	Bearing, End
2	M05-0773-000	Gasket, End Bearing (Linear Hopper)
2	09063146	Retainer, End Bearing
		Use: 2 SAE Washer (5/16) (C02-0312-020)
		2 Wing Nut (5/16) (C01-0312-020)
3	140694	Bearing, Center & Intermediate
3	140677	Retainer, Center & Intermediate Bearing
		Use: 3 SAE Washer (5/16) (C02-0312-020)
		3 Wing Nut (5/16) (C01-0312-020)
5	14071	Journal, Rotor Bar (5/8 Hex)
		Use: 5 Spring Pin (3/16 x 1) (C23-0187-140)
2	141069-3	Rotor Bar, Rubber, Center
2	141069-4	Rotor Bar, Rubber, End
1	14108011	Bottom & Slide Assembly, 10-Foot, 20-Openings
		Use: 4 Rear Hanger (0108016-24)
		8 Nylon Grip Washer (1/4) (C02-0250-011)
		8 Whiz Flange Nut (3/16) (C01-0187-030)
		4 Screw, Sheet Metal (#10-16 x 5/16) (C07-0187-040)
		1 Cam Gauge, Double (0906375-C1)
		2 SAE Washer (5/16) (C02-0312-020)
		1 Wing Nut (5/16) (C01-0312-020)
		10 HHTC (5/16 x 1/2) (C03-0312-011)



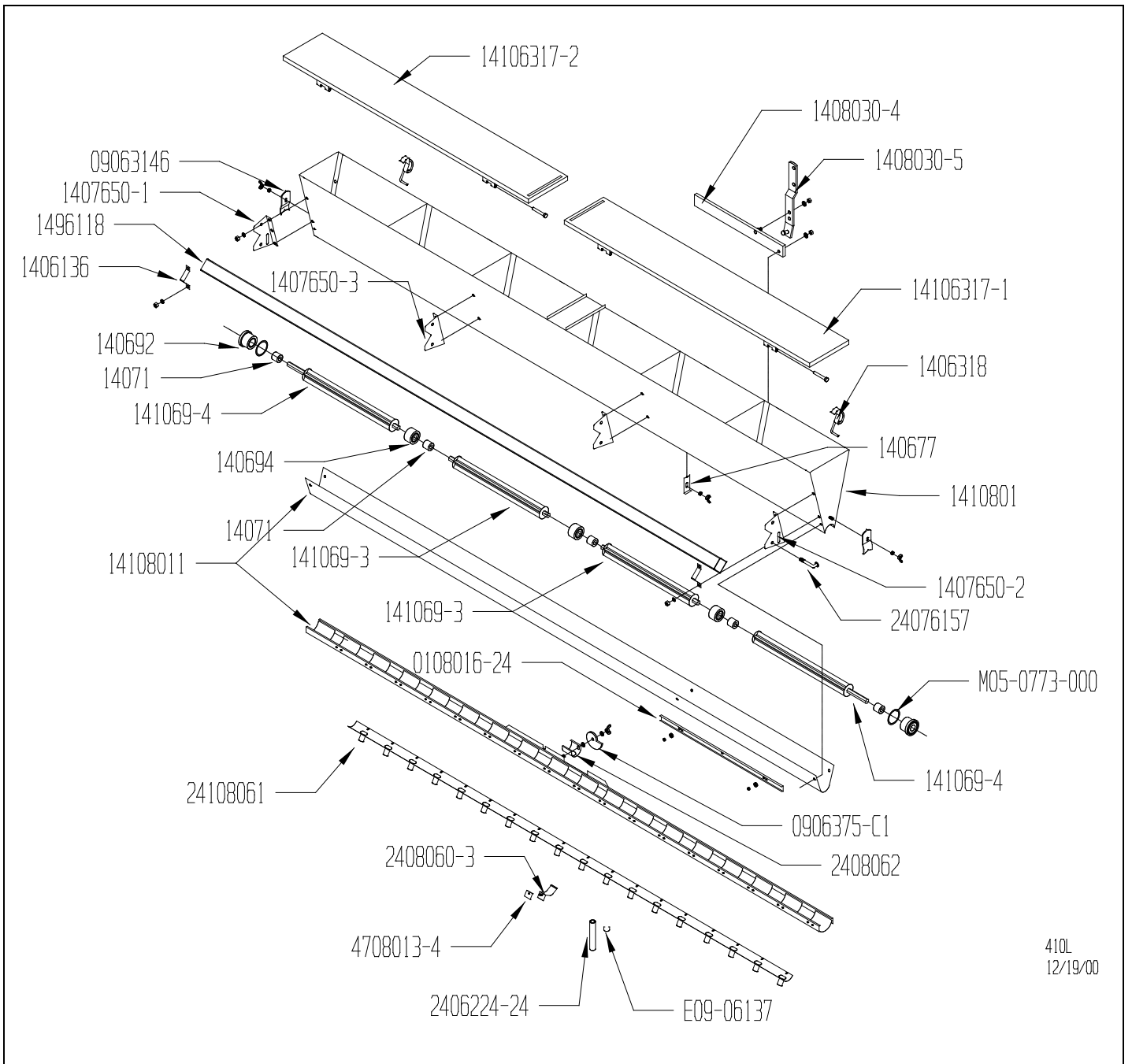

410L  
12/19/00

GDY-410L-PPL  
 Drawing: 410L  
 March 6, 2012  
 Revised From (5/22/09)  
 Printed in the USA